

COUNCIL MEETING AGENDA

Casper City Council
City Hall, Council Chambers
Tuesday, October 18, 2022, 6:00 p.m.



COUNCIL POLICY PUBLIC STATEMENTS

- I. Members of the Public Wishing to Speak to an Item Already on the Agenda, Other Than a Public Hearing, or Second or Third Reading Ordinance, Must Submit a Request to the City Clerk's Office by 12:00 Noon on the Monday Immediately Preceding the Council Meeting, or May Speak During the Communications from Persons Present.
- II. When Speaking to the City Council Please:
 - Clearly State Your Name and Address.
 - Direct all questions/comments to the Mayor and only the Mayor.
 - No personal attacks on staff or Council.
 - Speak to the City Council with Civility and Decorum.
- III. The City Council Will Not Respond to Any Comments or Questions Concerning Personnel Matters. Any Such Comments or Questions Will be Handled by the Appropriate Persons. Public Hearing Comments and Presentations Will be Limited to Five Minutes or Less per Person, nor Will Time Extensions be Permitted. No Duplication of Speakers will be Allowed.
- IV. Questions Posed by Speakers May, or May Not be Responded to by Council Members.
- V. Willful Disruption of, or the Breach of the Peace at, a Council Meeting may Result in the Removal of any Such Individuals or Groups from the Council Chambers.
(These Guidelines Are Also Posted at the Podium in the Council Chambers)

Please silence cell phones during the City Council meeting.

Entrance to the meetings is the east door off David Street. Face coverings are encouraged for those individuals who have not been fully vaccinated against COVID-19. Public input via email is encouraged: CouncilComments@casperwv.gov

AGENDA

1. ROLL CALL
2. PLEDGE OF ALLEGIANCE
3. CONSIDERATION OF BILLS AND CLAIMS

We are **CASPER**

Communication Accountability Stewardship Professionalism Efficiency Responsiveness

4. COMMUNICATIONS

A. From Persons Present

5. ESTABLISH DATE OF PUBLIC HEARING

A. Consent

1. Establish November 1, 2022, as the Public Hearing Date for Consideration of:

- a. An Ordinance **Amending Chapter 9.08 – Offenses Against the Person**, of the Casper Municipal Code, to Add Section 9.08.020 “Malicious Harms Based on Race, Color, Religion, Sex, Sexual Orientation, Gender Identity, Gender Expression, National Origin, or Disability.

6. CANCEL & RE-ESTABLISH DATE OF PUBLIC HEARING

A. Consent

1. **Cancel the October 18, 2022 Public Hearing, and Re-Establish November 1, 2022** as the Date of the Public Hearing for Consideration of an Ordinance Repealing and Replacing Ordinance No. 16-97 Codified as Chapter 8.08, **Private Intrusion Alarms**, of the Casper Municipal Code.

7. THIRD READING ORDINANCE

A. Ordinance Approving a Partial Plat, Vacation, Replat, Vacation of Public Parkland and a Zone Change for the **North Platte River Park No. 2 Subdivision**.

1. Communications from Persons Present

8. RESOLUTIONS

A. Consent

1. Authorizing a Contract between the City of Casper **KLJ Engineering, Inc.** for the **Evansville Texas Street Extension Study**.
2. Transitioning to a **ServiceFee Model for Utility Merchant Processing Accounts with DrivePayments**.
3. Authorizing the **Release of Various Local Assessment District Liens Regarding Coates Road** Local Assessment District 158.
4. Authorizing a Contract for Professional Services with **WLC Engineering, Surveying, and Planning, Inc.**, in the Amount of \$370,098.00, for the **Westridge Addition Improvements**, Project No. 21-065.

We are **CASPER**

Communication Accountability Stewardship Professionalism Efficiency Responsiveness

5. **Ratifying and Approving a Lease Agreement** between the City of Casper, Wyoming, a Wyoming Municipal Corporation and the **Charles E. Piersall, Chapter of the Izaak Walton League of America.**

9. MINUTE ACTION

A. Consent

1. Authorizing the **Purchase of Three (3) New Golf Course Green Mowers** in the Total Amount of \$167,982.00, Before Trade-In, for Use by the **Casper Municipal Golf Course** of the Parks, Recreation, and Public Facilities Department.
2. Authorizing the **Purchase of One (1) New One-Ton 4x4 Pickup with Snow Plow, Dump Bed, and Accessories** in the Total Amount of \$88,189.00, Before Trade-In, for Use by the **Weed and Pest Division** of the Parks, Recreation, and Public Facilities Department.
3. Authorizing the **Purchase of One (1) New 3000 Ton Per Hour Loader Mounted Snow Blower** in the Total Amount of \$239,850.00, Before Trade-In, for Use by the **Streets and Traffic Division** of the Public Services Department.

10. INTRODUCTION OF MEASURES AND PROPOSALS BY MEMBERS OF THE CITY COUNCIL

11. ADJOURN INTO EXECUTIVE SESSION – PERSONNEL & LITIGATION

12. ADJOURNMENT OF REGULAR MEETING

Upcoming Council Meetings

Regular Council Meetings

6:00 p.m. Tuesday, November 1, 2022 – Council Chambers

6:00 p.m. Tuesday, November 14, 2022 – Council Chambers

Work Sessions

4:30 p.m. Tuesday, October 25, 2022 – Council Meeting Room

4:30 p.m. Tuesday, November 8, 2022 – Council Meeting Room

ZONING CLASSIFICATIONS

FC	Major Flood Channels & Riverbanks	PUD	Planned Unit Development
AG	Urban Agriculture	HM	Hospital Medical
R-1	Residential Estate	C-1	Neighborhood Convenience
R-2	One Unit Residential	C-2	General Business
R-3	One to Four Unit Residential	C-3	Central Business
R-4	High-Density Residential	C-4	Highway Business
R-5	Mixed Residential	M-1	Limited Industrial
R-6	Manufactured Home (Mobile) Park	M-2	General Industrial
PH	Park Historic	SMO	Soil Management Overlay

We are **CASPER**

Communication Accountability Stewardship Professionalism Efficiency Responsiveness

City of Casper - Bills and Claims for October 18, 2022

0970 CED

0970 CED	Traffic Control	Photo cell & LED bulb for luminaire repairs	\$137.08
0970 CED	Traffic Control	LED bulbs for luminaire repair	\$345.21
<i>0970 CED - Total For Traffic Control</i>			\$482.29
0970 CED - ALL DEPARTMENTS			\$482.29

19TH HOLE RESTAURANT

19TH HOLE RESTAURANT	City Council	Lunch meeting	\$47.23
<i>19TH HOLE RESTAURANT - Total For City Council</i>			\$47.23
19TH HOLE RESTAURANT	City Manager	Lunch meeting	\$25.49
<i>19TH HOLE RESTAURANT - Total For City Manager</i>			\$25.49
19TH HOLE RESTAURANT - ALL DEPARTMENTS			\$72.72

2530 - CPS DSTRBTRS

2530 - CPS DSTRBTRS	Cemetery	Irrigation fittings	\$19.69
<i>2530 - CPS DSTRBTRS - Total For Cemetery</i>			\$19.69
2530 - CPS DSTRBTRS	Parks - Parks Maint.	Irrigation repair Highland Park	\$19.90
2530 - CPS DSTRBTRS	Parks - Parks Maint.	Heads for Matt Campfield	\$19.48
2530 - CPS DSTRBTRS	Parks - Parks Maint.	Irrigation repair Bryan Stock	\$30.87
2530 - CPS DSTRBTRS	Parks - Parks Maint.	spray gun and paint for locates	\$93.09
2530 - CPS DSTRBTRS	Parks - Parks Maint.	quick coupler key for blowout	\$84.23
2530 - CPS DSTRBTRS	Parks - Parks Maint.	quick coupling valve for Beverly Street Under	\$87.07
2530 - CPS DSTRBTRS	Parks - Parks Maint.	dc solenoid and slip fix for Beverly Street and	\$45.14
2530 - CPS DSTRBTRS	Parks - Parks Maint.	Purchase of incorrect part for Highland park i	\$37.26
2530 - CPS DSTRBTRS	Parks - Parks Maint.	Irrigation repair adventureland	\$72.94
2530 - CPS DSTRBTRS	Parks - Parks Maint.	Refund of wrong irrigation part for Highland	(\$37.26)
<i>2530 - CPS DSTRBTRS - Total For Parks - Parks Maint.</i>			\$452.72
2530 - CPS DSTRBTRS - ALL DEPARTMENTS			\$472.41

307 JANITORIAL LLC

307 JANITORIAL LLC	Buildings & Structures Fund	Cleaning service	\$4,977.05
--------------------	-----------------------------	------------------	------------

307 JANITORIAL LLC	Buildings & Structures Fund	Cleaning service	\$5,823.35
<i>307 JANITORIAL LLC - Total For Buildings & Structures Fund</i>			<i>\$10,800.40</i>
307 JANITORIAL LLC - ALL DEPARTMENTS			\$10,800.40

4IMPRINT, INC

4IMPRINT, INC	Rec Center - Operations	CRC FDA Uniform Vests	\$570.92
<i>4IMPRINT, INC - Total For Rec Center - Operations</i>			<i>\$570.92</i>
4IMPRINT, INC - ALL DEPARTMENTS			\$570.92

6H GROUP LLC

6H GROUP LLC	Metro Animal Shelter	Dog & cat food	\$798.10
6H GROUP LLC	Metro Animal Shelter	Dog food, cat food & puppy food	\$742.85
6H GROUP LLC	Metro Animal Shelter	Dog food, cat food & puppy food	\$896.25
6H GROUP LLC	Metro Animal Shelter	Dog food, cat food & puppy food	\$873.60
6H GROUP LLC	Metro Animal Shelter	Dog food, cat food & puppy food	\$733.80
6H GROUP LLC	Metro Animal Shelter	Dog food, cat food & puppy food	\$505.80
<i>6H GROUP LLC - Total For Metro Animal Shelter</i>			<i>\$4,550.40</i>
6H GROUP LLC	Police Administration	Dog food	\$289.00
<i>6H GROUP LLC - Total For Police Administration</i>			<i>\$289.00</i>
6H GROUP LLC - ALL DEPARTMENTS			\$4,839.40

A.M.B.I. & SHIPPING,

A.M.B.I. & SHIPPING,	Balefill - Disposal & Landfill	Postage / mailing service	\$27.14
<i>A.M.B.I. & SHIPPING, - Total For Balefill - Disposal & Landfill</i>			<i>\$27.14</i>
A.M.B.I. & SHIPPING,	City Attorney	Postage / mailing service	\$175.95
<i>A.M.B.I. & SHIPPING, - Total For City Attorney</i>			<i>\$175.95</i>
A.M.B.I. & SHIPPING,	City Manager	Postage / Mailing service	\$1.86
<i>A.M.B.I. & SHIPPING, - Total For City Manager</i>			<i>\$1.86</i>
A.M.B.I. & SHIPPING,	Customer Service	Postage / mailing service	\$447.06
<i>A.M.B.I. & SHIPPING, - Total For Customer Service</i>			<i>\$447.06</i>
A.M.B.I. & SHIPPING,	Engineering	Postage / mailing service	\$38.39
<i>A.M.B.I. & SHIPPING, - Total For Engineering</i>			<i>\$38.39</i>
A.M.B.I. & SHIPPING,	Human Resources	Postage / mailing service	\$8.49

<i>A.M.B.I. & SHIPPING, - Total For Human Resources</i>			<i>\$8.49</i>
A.M.B.I. & SHIPPING,	Police Administration	Postage / mailing service	\$381.36
A.M.B.I. & SHIPPING,	Police Administration	Postage / Mailing service	\$30.00
<i>A.M.B.I. & SHIPPING, - Total For Police Administration</i>			<i>\$411.36</i>
A.M.B.I. & SHIPPING,	Refuse - Residential	Postage / mailing service	\$72.36
<i>A.M.B.I. & SHIPPING, - Total For Refuse - Residential</i>			<i>\$72.36</i>
A.M.B.I. & SHIPPING,	Weed & Pest Fund	Postage / mailing service	\$3.05
<i>A.M.B.I. & SHIPPING, - Total For Weed & Pest Fund</i>			<i>\$3.05</i>
A.M.B.I. & SHIPPING, - ALL DEPARTMENTS			\$1,185.66

AAKER SIGNS & DESIGN

AAKER SIGNS & DESIGN	Community Development	Digitally printed banners	\$945.00
<i>AAKER SIGNS & DESIGN - Total For Community Development</i>			<i>\$945.00</i>
AAKER SIGNS & DESIGN - ALL DEPARTMENTS			\$945.00

ABLE CARD (MOTO)

ABLE CARD (MOTO)	Hogadon - Operations	Pass blanks	\$255.50
<i>ABLE CARD (MOTO) - Total For Hogadon - Operations</i>			<i>\$255.50</i>
ABLE CARD (MOTO) - ALL DEPARTMENTS			\$255.50

AC TREE SERVICE

AC TREE SERVICE	Parks - Urban Forestry	Tree trimming & shaping	\$220.00
<i>AC TREE SERVICE - Total For Parks - Urban Forestry</i>			<i>\$220.00</i>
AC TREE SERVICE - ALL DEPARTMENTS			\$220.00

ACADEMY ONLINE COURS

ACADEMY ONLINE COURS	Fire-EMS Administration	Fire Rescue Academy Subscription for CMEs	\$89.00
<i>ACADEMY ONLINE COURS - Total For Fire-EMS Administration</i>			<i>\$89.00</i>
ACADEMY ONLINE COURS - ALL DEPARTMENTS			\$89.00

AED.US_CORO MEDICAL

AED.US_CORO MEDICAL	Fire-EMS Operations	Laerdal Compact Suction Unit	\$1,234.80
---------------------	---------------------	------------------------------	------------

AED.US_CORO MEDICAL - Total For Fire-EMS Operations \$1,234.80

AED.US_CORO MEDICAL - ALL DEPARTMENTS \$1,234.80

AIRGAS USA LLC

AIRGAS USA LLC Balefill - Baler Processing Plazma table tips \$426.25

AIRGAS USA LLC - Total For Balefill - Baler Processing \$426.25

AIRGAS USA LLC Balefill - Diversion & Special Latex gloves \$150.57

AIRGAS USA LLC - Total For Balefill - Diversion & Special \$150.57

AIRGAS USA LLC Refuse - Commercial Hydration supplies - popsicles \$41.55

AIRGAS USA LLC Refuse - Commercial Safety glasses/latex gloves/face shield/ear pl \$311.34

AIRGAS USA LLC - Total For Refuse - Commercial \$352.89

AIRGAS USA LLC Refuse - Residential Safety glasses/latex gloves/face shield/ear pl \$242.57

AIRGAS USA LLC - Total For Refuse - Residential \$242.57

AIRGAS USA LLC - ALL DEPARTMENTS \$1,172.28

ALBERTSONS #0060

ALBERTSONS #0060 Health Insurance Fund Prepared for Prevention Vendor Refreshmen \$35.96

ALBERTSONS #0060 - Total For Health Insurance Fund \$35.96

ALBERTSONS #0060 - ALL DEPARTMENTS \$35.96

ALBERTSONS #0062

ALBERTSONS #0062 Parks - Parks Maint. NRPA Washington Park Discussion Water Bot \$4.49

ALBERTSONS #0062 Parks - Parks Maint. Coffee \$10.99

ALBERTSONS #0062 - Total For Parks - Parks Maint. \$15.48

ALBERTSONS #0062 - ALL DEPARTMENTS \$15.48

ALSCO

ALSCO Balefill - Disposal & Landfill Professional Laundry Services (\$31.82)

ALSCO Balefill - Disposal & Landfill Professional Laundry Services \$90.64

ALSCO Balefill - Disposal & Landfill Professional Laundry Services \$84.50

ALSCO Balefill - Disposal & Landfill Professional Laundry Services \$80.50

ALSCO Balefill - Disposal & Landfill Professional Laundry Services \$58.82

ALSCO - Total For Balefill - Disposal & Landfill \$282.64

ALSCO	Fleet Maintenance Fund	Laundry service	\$128.79
ALSCO	Fleet Maintenance Fund	Laundry service	\$171.54
<i>ALSCO - Total For Fleet Maintenance Fund</i>			<i>\$300.33</i>
ALSCO	Refuse - Residential	Professional Laundry Services	\$110.56
ALSCO	Refuse - Residential	Professional Laundry Services	\$110.56
<i>ALSCO - Total For Refuse - Residential</i>			<i>\$221.12</i>
ALSCO	Regional Water Operations	Professional Laundry Services	\$138.97
<i>ALSCO - Total For Regional Water Operations</i>			<i>\$138.97</i>
ALSCO	Sewer Wastewater Collection	Professional Laundry Services	\$52.22
ALSCO	Sewer Wastewater Collection	Professional Laundry Services	\$52.22
<i>ALSCO - Total For Sewer Wastewater Collection</i>			<i>\$104.44</i>
ALSCO	Streets	Professional Laundry Services	\$134.40
ALSCO	Streets	Professional Laundry Services	\$133.40
ALSCO	Streets	Professional Laundry Services	\$133.40
ALSCO	Streets	Professional Laundry Services	\$133.40
<i>ALSCO - Total For Streets</i>			<i>\$534.60</i>
ALSCO	WWTP Operations	Professional Laundry Services	\$145.24
<i>ALSCO - Total For WWTP Operations</i>			<i>\$145.24</i>
ALSCO - ALL DEPARTMENTS			\$1,727.34

AMAZON.COM 145I81VX2

AMAZON.COM 145I81VX2	Regional Water Operations	New Graduated Cylinders for Actiflo Sand Sa	\$39.00
<i>AMAZON.COM 145I81VX2 - Total For Regional Water Operations</i>			<i>\$39.00</i>

AMAZON.COM 145I81VX2 - ALL DEPARTMENTS **\$39.00**

AMAZON.COM 1F3887RL0

AMAZON.COM 1F3887RL0	Balefill - Disposal & Landfill	KEURIG FILTER	\$15.67
<i>AMAZON.COM 1F3887RL0 - Total For Balefill - Disposal & Landfill</i>			<i>\$15.67</i>

AMAZON.COM 1F3887RL0 - ALL DEPARTMENTS **\$15.67**

AMAZON.COM 1M7H57761

AMAZON.COM 1M7H57761	Police Investigations	BOOK STORES	\$45.08
<i>AMAZON.COM 1M7H57761 - Total For Police Investigations</i>			<i>\$45.08</i>

AMAZON.COM 1M7H57761 - ALL DEPARTMENTS \$45.08

AMAZON.COM 1M89V57Z2

AMAZON.COM 1M89V57Z2 Hogadon - Operations Printer pass ink \$301.44

AMAZON.COM 1M89V57Z2 - Total For Hogadon - Operations \$301.44

AMAZON.COM 1M89V57Z2 - ALL DEPARTMENTS \$301.44

AMERICAN GAS LAMP WO

AMERICAN GAS LAMP WO Traffic Control 3 ignitors and top cap for Goodstein lot gas l \$1,303.00

AMERICAN GAS LAMP WO - Total For Traffic Control \$1,303.00

AMERICAN GAS LAMP WO - ALL DEPARTMENTS \$1,303.00

AMERI-TECH EQUIPMENT

AMERI-TECH EQUIPMENT Refuse - Residential Traveling covers assembly, snap rings, grease \$2,701.58

AMERI-TECH EQUIPMENT Refuse - Residential Equipment repair \$1,286.71

AMERI-TECH EQUIPMENT - Total For Refuse - Residential \$3,988.29

AMERI-TECH EQUIPMENT - ALL DEPARTMENTS \$3,988.29

AMZN Mktp US

AMZN Mktp US Balefill - Baler Processing BEARINGS FOR MAINTENANCE BLDG \$42.47

AMZN Mktp US Balefill - Baler Processing STYLUS \$11.04

AMZN Mktp US Balefill - Baler Processing ROLLER BALL TRANSFER BEARINGS BALER \$77.82

AMZN Mktp US Balefill - Baler Processing COFFEE CAROUSEL \$24.98

AMZN Mktp US Balefill - Baler Processing IPAD COVER FOR BALER \$32.23

AMZN Mktp US - Total For Balefill - Baler Processing \$188.54

AMZN Mktp US Balefill - Disposal & Landfill LDF SUPPLIES \$103.60

AMZN Mktp US Balefill - Disposal & Landfill KEURIG MAINTENANCE KIT \$30.99

AMZN Mktp US Balefill - Disposal & Landfill SUPPLIES TRUCK BARN TRAINING ROOM \$16.14

AMZN Mktp US Balefill - Disposal & Landfill KEURIG DESCALING SOLUTION \$37.11

AMZN Mktp US Balefill - Disposal & Landfill LDF SUPPLIES \$46.25

AMZN Mktp US Balefill - Disposal & Landfill SAFETY MEETING CUPPLIES \$44.75

AMZN Mktp US Balefill - Disposal & Landfill SAFETY MEETING SUPPLIES \$26.05

AMZN Mktp US Balefill - Disposal & Landfill COFFEE FILTERS \$18.71

<i>AMZN Mktp US - Total For Balefill - Disposal & Landfill</i>			\$323.60
AMZN Mktp US	Balefill - Diversion & Special	COFFEE HOLDER	\$24.98
AMZN Mktp US	Balefill - Diversion & Special	PURELL HAND SANI	\$66.00
<i>AMZN Mktp US - Total For Balefill - Diversion & Special</i>			\$90.98
AMZN Mktp US	Community Development	Refunded for wrong item being sent	(\$32.23)
AMZN Mktp US	Community Development	User guide holder	\$32.23
AMZN Mktp US	Community Development	Desktop guide packet holder	\$45.88
<i>AMZN Mktp US - Total For Community Development</i>			\$45.88
AMZN Mktp US	Fire-EMS Operations	Magill Forceps	\$35.52
AMZN Mktp US	Fire-EMS Operations	Intubation Kits	\$209.98
AMZN Mktp US	Fire-EMS Operations	Pool Noodles for Car Seat Installs	\$72.45
<i>AMZN Mktp US - Total For Fire-EMS Operations</i>			\$317.95
AMZN Mktp US	Police Administration	BOOK STORES	\$25.98
AMZN Mktp US	Police Administration	BOOK STORES	\$12.95
AMZN Mktp US	Police Administration	BOOK STORES	\$21.98
AMZN Mktp US	Police Administration	BOOK STORES	\$16.82
AMZN Mktp US	Police Administration	BOOK STORES	\$5.99
AMZN Mktp US	Police Administration	BOOK STORES	\$1.69
AMZN Mktp US	Police Administration	BOOK STORES	\$46.33
AMZN Mktp US	Police Administration	BOOK STORES	\$14.99
<i>AMZN Mktp US - Total For Police Administration</i>			\$146.73
AMZN Mktp US	Police State Grants	BOOK STORES	\$28.99
<i>AMZN Mktp US - Total For Police State Grants</i>			\$28.99
AMZN Mktp US	Public Transit - CARES Act	BOOK STORES	\$174.99
<i>AMZN Mktp US - Total For Public Transit - CARES Act</i>			\$174.99
AMZN Mktp US	Refuse - Commercial	SUPPLIES TRUCK BARN TRAINING ROOM	\$16.14
<i>AMZN Mktp US - Total For Refuse - Commercial</i>			\$16.14
AMZN Mktp US	Water Distribution	Wrench Set for 660260 - Vehicle Supplies	\$34.99
AMZN Mktp US	Water Distribution	Remotes openers for trucks / Vehicles Suppli	\$178.90
AMZN Mktp US	Water Distribution	5Port USB Hub Smart Charging Port - Techno	\$27.98
<i>AMZN Mktp US - Total For Water Distribution</i>			\$241.87
AMZN Mktp US - ALL DEPARTMENTS			\$1,575.67

APCO INTERNATIONAL I

APCO INTERNATIONAL I	Police Career Services	BUSINESS SERVICES NOT ELSEWHERE CLASSI	\$675.00
----------------------	------------------------	--	----------

APCO INTERNATIONAL I - Total For Police Career Services \$675.00

APCO INTERNATIONAL I - ALL DEPARTMENTS \$675.00

APPLE COMPUTER, INC.

APPLE COMPUTER, INC. Fire-EMS Administration Cloud Storage \$0.99

APPLE COMPUTER, INC. - Total For Fire-EMS Administration \$0.99

APPLE COMPUTER, INC. - ALL DEPARTMENTS \$0.99

APPLEBEES 9380463938

APPLEBEES 9380463938 Public Transit - CARES Act EATING PLACES, RESTAURANTS \$16.48

APPLEBEES 9380463938 - Total For Public Transit - CARES Act \$16.48

APPLEBEES 9380463938 - ALL DEPARTMENTS \$16.48

APSTYLEBOOK.COM

APSTYLEBOOK.COM City Manager AP Style Guide Subscriptions \$109.99

APSTYLEBOOK.COM - Total For City Manager \$109.99

APSTYLEBOOK.COM - ALL DEPARTMENTS \$109.99

ARCADIA PUBLISHING

ARCADIA PUBLISHING General Fund Revenue Books for resale in gift shop \$699.34

ARCADIA PUBLISHING - Total For General Fund Revenue \$699.34

ARCADIA PUBLISHING - ALL DEPARTMENTS \$699.34

ARROWHEAD HEATING &

ARROWHEAD HEATING & Balefill - Disposal & Landfill Scheduled Maintenance - Filter Change \$151.25

ARROWHEAD HEATING & Balefill - Disposal & Landfill Scheduled Maintenance \$180.00

ARROWHEAD HEATING & - Total For Balefill - Disposal & Landfill \$331.25

ARROWHEAD HEATING & - ALL DEPARTMENTS \$331.25

AT & T CORP

AT & T CORP Community Development Acct #287298906028 \$433.44

<i>AT & T CORP - Total For Community Development</i>			\$433.44
AT & T CORP	Fire-EMS Administration	Acct #287292151247	\$640.00
<i>AT & T CORP - Total For Fire-EMS Administration</i>			\$640.00
AT & T CORP	Metro Animal Control	Acct #287279602134	\$450.00
<i>AT & T CORP - Total For Metro Animal Control</i>			\$450.00
AT & T CORP	Police Administration	Acct #287279602134	\$16,364.93
<i>AT & T CORP - Total For Police Administration</i>			\$16,364.93
AT & T CORP	Public Safety Communication	Acct #051 221 2711 001	\$68.50
<i>AT & T CORP - Total For Public Safety Communications</i>			\$68.50
AT & T CORP	Sewer Wastewater Collection	Acct #287295228508	\$160.16
<i>AT & T CORP - Total For Sewer Wastewater Collection</i>			\$160.16
AT & T CORP	Water Distribution	Acct #287290345044	\$359.16
AT & T CORP	Water Distribution	Acct #287290345044	\$359.16
<i>AT & T CORP - Total For Water Distribution</i>			\$718.32
AT & T CORP	Water Meters	Acct #287290345044	\$161.36
AT & T CORP	Water Meters	Acct #287290345044	\$161.36
<i>AT & T CORP - Total For Water Meters</i>			\$322.72
AT & T CORP - ALL DEPARTMENTS			\$19,158.07

ATLAS OFFICE PRODUCT

ATLAS OFFICE PRODUCT	Balefill - Disposal & Landfill	Office supplies	\$566.96
ATLAS OFFICE PRODUCT	Balefill - Disposal & Landfill	Office supplies	\$10.12
ATLAS OFFICE PRODUCT	Balefill - Disposal & Landfill	Office supplies	\$95.40
<i>ATLAS OFFICE PRODUCT - Total For Balefill - Disposal & Landfill</i>			\$672.48
ATLAS OFFICE PRODUCT	Balefill - Diversion & Special	Office supplies	\$159.97
ATLAS OFFICE PRODUCT	Balefill - Diversion & Special	Office supplies	\$29.90
ATLAS OFFICE PRODUCT	Balefill - Diversion & Special	Office supplies	\$79.80
ATLAS OFFICE PRODUCT	Balefill - Diversion & Special	Office supplies	\$560.92
ATLAS OFFICE PRODUCT	Balefill - Diversion & Special	Office supplies	\$286.65
<i>ATLAS OFFICE PRODUCT - Total For Balefill - Diversion & Special</i>			\$1,117.24
ATLAS OFFICE PRODUCT	City Attorney	Office supplies	\$12.74
ATLAS OFFICE PRODUCT	City Attorney	Office supplies	\$9.63
ATLAS OFFICE PRODUCT	City Attorney	Office supplies	\$94.33
<i>ATLAS OFFICE PRODUCT - Total For City Attorney</i>			\$116.70
ATLAS OFFICE PRODUCT	City Council	2- name plates	\$17.00

<i>ATLAS OFFICE PRODUCT - Total For City Council</i>			<i>\$17.00</i>
ATLAS OFFICE PRODUCT	Community Development	Office supplies	\$11.06
<i>ATLAS OFFICE PRODUCT - Total For Community Development</i>			<i>\$11.06</i>
ATLAS OFFICE PRODUCT	Customer Service	TONER & WIRELESS MOUSE	\$104.85
ATLAS OFFICE PRODUCT	Customer Service	EASEL POST IT PADS AND TONER CARTRIDGE	\$240.93
<i>ATLAS OFFICE PRODUCT - Total For Customer Service</i>			<i>\$345.78</i>
ATLAS OFFICE PRODUCT	Engineering	Yearly Calendar	\$48.37
<i>ATLAS OFFICE PRODUCT - Total For Engineering</i>			<i>\$48.37</i>
ATLAS OFFICE PRODUCT	Finance	Chair for Katie Pearson	\$286.13
ATLAS OFFICE PRODUCT	Finance	TONER & WIRELESS MOUSE	\$28.99
<i>ATLAS OFFICE PRODUCT - Total For Finance</i>			<i>\$315.12</i>
ATLAS OFFICE PRODUCT	Fleet Maintenance Fund	Office furniture	\$1,786.65
<i>ATLAS OFFICE PRODUCT - Total For Fleet Maintenance Fund</i>			<i>\$1,786.65</i>
ATLAS OFFICE PRODUCT	Human Resources	Office furniture	\$286.13
ATLAS OFFICE PRODUCT	Human Resources	Office furniture	\$272.68
<i>ATLAS OFFICE PRODUCT - Total For Human Resources</i>			<i>\$558.81</i>
ATLAS OFFICE PRODUCT	Police Administration	Office supplies	\$196.42
ATLAS OFFICE PRODUCT	Police Administration	Office supplies	\$47.42
ATLAS OFFICE PRODUCT	Police Administration	Office supplies	\$23.71
ATLAS OFFICE PRODUCT	Police Administration	Office supplies	\$205.56
ATLAS OFFICE PRODUCT	Police Administration	Office furniture	\$849.00
ATLAS OFFICE PRODUCT	Police Administration	Office supplies	\$259.01
ATLAS OFFICE PRODUCT	Police Administration	Office supplies	\$19.48
ATLAS OFFICE PRODUCT	Police Administration	Office supplies	\$179.35
<i>ATLAS OFFICE PRODUCT - Total For Police Administration</i>			<i>\$1,779.95</i>
ATLAS OFFICE PRODUCT	Refuse - Residential	Office supplies	\$145.02
<i>ATLAS OFFICE PRODUCT - Total For Refuse - Residential</i>			<i>\$145.02</i>
ATLAS OFFICE PRODUCT	Water Distribution	Document Holder for Data Entry - Bldg Suppl	\$18.60
<i>ATLAS OFFICE PRODUCT - Total For Water Distribution</i>			<i>\$18.60</i>
ATLAS OFFICE PRODUCT - ALL DEPARTMENTS			\$6,932.78

AWWA.ORG

AWWA.ORG	Water Administration	M-36 Manual	\$191.50
<i>AWWA.ORG - Total For Water Administration</i>			<i>\$191.50</i>

AWWA.ORG - ALL DEPARTMENTS

\$191.50

B&B RUBBER STAMP

B&B RUBBER STAMP	Police Administration	Office supplies	\$61.90
B&B RUBBER STAMP	Police Administration	STATIONARY, OFFICE AND SCHOOL SUPPLY S	\$33.55
<i>B&B RUBBER STAMP - Total For Police Administration</i>			\$95.45
B&B RUBBER STAMP	Water Distribution	Voucher Stamp Building Supplies	\$24.95
<i>B&B RUBBER STAMP - Total For Water Distribution</i>			\$24.95
B&B RUBBER STAMP - ALL DEPARTMENTS			\$120.40

BACK COUNTRY BADGER

BACK COUNTRY BADGER	Water Distribution	VM880 Metal Detector & VLoc3Pro Locator	\$6,507.00
<i>BACK COUNTRY BADGER - Total For Water Distribution</i>			\$6,507.00
BACK COUNTRY BADGER - ALL DEPARTMENTS			\$6,507.00

BADGER METER INC

BADGER METER INC	Water Meters	Orion Cellular Meter	\$162.87
<i>BADGER METER INC - Total For Water Meters</i>			\$162.87
BADGER METER INC - ALL DEPARTMENTS			\$162.87

BAILEY'S ACE HARDWAR

BAILEY'S ACE HARDWAR	Balefill - Disposal & Landfill	Ice melt & gas can	\$916.11
<i>BAILEY'S ACE HARDWAR - Total For Balefill - Disposal & Landfill</i>			\$916.11
BAILEY'S ACE HARDWAR	Balefill - Diversion & Special	Plastic bucket & lid	\$8.58
<i>BAILEY'S ACE HARDWAR - Total For Balefill - Diversion & Special</i>			\$8.58
BAILEY'S ACE HARDWAR	Refuse - Commercial	Plastic buckets/lids, scoops & wasp spray	\$158.88
<i>BAILEY'S ACE HARDWAR - Total For Refuse - Commercial</i>			\$158.88
BAILEY'S ACE HARDWAR - ALL DEPARTMENTS			\$1,083.57

BAILEYS ACE HDWE

BAILEYS ACE HDWE	Buildings & Structures Fund	Return of repair supplies for Aquatics Center	(\$4.50)
BAILEYS ACE HDWE	Buildings & Structures Fund	Repair supplies for Aquatics Center - Baileys	\$11.85

BAILEYS ACE HDWE	Buildings & Structures Fund	HVAC PM Supplies for Ice Arena - Baileys Ace	\$33.83
<i>BAILEYS ACE HDWE - Total For Buildings & Structures Fund</i>			<i>\$41.18</i>
BAILEYS ACE HDWE	Fire-EMS Operations	Supplies for new engines	\$19.30
<i>BAILEYS ACE HDWE - Total For Fire-EMS Operations</i>			<i>\$19.30</i>
BAILEYS ACE HDWE	Parks - Parks Maint.	Spray paint	\$13.98
BAILEYS ACE HDWE	Parks - Parks Maint.	Replacement extension cord end	\$7.99
<i>BAILEYS ACE HDWE - Total For Parks - Parks Maint.</i>			<i>\$21.97</i>
BAILEYS ACE HDWE	Water Distribution	Flashlight for 660242 / Other materials and s	\$29.99
<i>BAILEYS ACE HDWE - Total For Water Distribution</i>			<i>\$29.99</i>
BAILEYS ACE HDWE - ALL DEPARTMENTS			\$112.44

BAR-D SIGNS, INC.

BAR-D SIGNS, INC.	Property Insurance Fund	CRC Digital Sign Replacement Claim 2022052	\$773.00
<i>BAR-D SIGNS, INC. - Total For Property Insurance Fund</i>			<i>\$773.00</i>
BAR-D SIGNS, INC.	Refuse - Commercial	Installation of signage	\$715.39
<i>BAR-D SIGNS, INC. - Total For Refuse - Commercial</i>			<i>\$715.39</i>
BAR-D SIGNS, INC. - ALL DEPARTMENTS			\$1,488.39

BED BATH & BEYOND

BED BATH & BEYOND	Municipal Court	MISCELLANEOUS HOUSE FURNISHING SPECI	\$67.18
<i>BED BATH & BEYOND - Total For Municipal Court</i>			<i>\$67.18</i>
BED BATH & BEYOND - ALL DEPARTMENTS			\$67.18

BELLA FUOCO

BELLA FUOCO	Fire-EMS Training	Lunch while in Cheyenne for RERT2 meeting	\$18.90
<i>BELLA FUOCO - Total For Fire-EMS Training</i>			<i>\$18.90</i>
BELLA FUOCO - ALL DEPARTMENTS			\$18.90

BEST BUY

BEST BUY	Fire-EMS Operations	Credit for returning TV that did not work and	(\$90.00)
BEST BUY	Fire-EMS Operations	TV for Station 5	\$379.99
<i>BEST BUY - Total For Fire-EMS Operations</i>			<i>\$289.99</i>

BEST BUY - ALL DEPARTMENTS \$289.99

BEST RUBBER MULCH LL

BEST RUBBER MULCH LL Capital Projects Fund Miscellaneous Item \$24,966.27

BEST RUBBER MULCH LL - Total For Capital Projects Fund \$24,966.27

BEST RUBBER MULCH LL - ALL DEPARTMENTS \$24,966.27

BEST WESTERN PLUS FR

BEST WESTERN PLUS FR Police Career Services BEST WESTERN HOTELS \$180.79

BEST WESTERN PLUS FR - Total For Police Career Services \$180.79

BEST WESTERN PLUS FR - ALL DEPARTMENTS \$180.79

BESTBUYCOM8066746113

BESTBUYCOM8066746113 City Council ipad charging cords and adapters \$96.00

BESTBUYCOM8066746113 - Total For City Council \$96.00

BESTBUYCOM8066746113 - ALL DEPARTMENTS \$96.00

BESTBUYCOM8066762000

BESTBUYCOM8066762000 Information Services Monitor Stand for C.Edwards \$114.99

BESTBUYCOM8066762000 - Total For Information Services \$114.99

BESTBUYCOM8066762000 - ALL DEPARTMENTS \$114.99

BIG D #29

BIG D #29 Fire-EMS Operations Fuel for travel to Cheyenne \$75.43

BIG D #29 - Total For Fire-EMS Operations \$75.43

BIG D #29 - ALL DEPARTMENTS \$75.43

BIG D #3

BIG D #3 Police Administration AUTOMATED FUEL DISPENSERS \$23.25

BIG D #3 - Total For Police Administration \$23.25

BIG D #3 - ALL DEPARTMENTS

\$23.25

BLACK HILLS ENERGY

BLACK HILLS ENERGY	Aquatics - Operations	Acct #7584 6122 74	\$4,549.77
<i>BLACK HILLS ENERGY - Total For Aquatics - Operations</i>			\$4,549.77
BLACK HILLS ENERGY	Aquatics- Marion Kreiner Ope	Acct #9723 1947 06	\$289.95
<i>BLACK HILLS ENERGY - Total For Aquatics- Marion Kreiner Oper.</i>			\$289.95
BLACK HILLS ENERGY	Aquatics- Mike Sedar Oper.	Acct #9723 1947 06	\$3,384.74
<i>BLACK HILLS ENERGY - Total For Aquatics- Mike Sedar Oper.</i>			\$3,384.74
BLACK HILLS ENERGY	Aquatics- Paradise Valley Ope	Acct #9723 1947 06	\$2,185.27
<i>BLACK HILLS ENERGY - Total For Aquatics- Paradise Valley Oper</i>			\$2,185.27
BLACK HILLS ENERGY	Aquatics- Washington Oper	Acct #9723 1947 06	\$1,251.97
<i>BLACK HILLS ENERGY - Total For Aquatics- Washington Oper</i>			\$1,251.97
BLACK HILLS ENERGY	Regional Water Operations	Acct #7513 1659 94	\$2,974.69
<i>BLACK HILLS ENERGY - Total For Regional Water Operations</i>			\$2,974.69
BLACK HILLS ENERGY	Sewer Wastewater Collection	Acct #6405 5357 61	\$33.99
<i>BLACK HILLS ENERGY - Total For Sewer Wastewater Collection</i>			\$33.99
BLACK HILLS ENERGY - ALL DEPARTMENTS			\$14,670.38

BLOEDORN LUMBER CO

BLOEDORN LUMBER CO	Capital Projects Fund	Concrete and mortar for door install at socce	\$409.89
BLOEDORN LUMBER CO	Capital Projects Fund	Forming material for wet well at soccer pum	\$66.17
<i>BLOEDORN LUMBER CO - Total For Capital Projects Fund</i>			\$476.06
BLOEDORN LUMBER CO	Fire-EMS Operations	Equipment for new engines	\$51.45
<i>BLOEDORN LUMBER CO - Total For Fire-EMS Operations</i>			\$51.45
BLOEDORN LUMBER CO	Public Transit - Operations	Screed board for rescue mission bust stop	\$15.33
<i>BLOEDORN LUMBER CO - Total For Public Transit - Operations</i>			\$15.33
BLOEDORN LUMBER CO	WWTP Operations	Paint	\$52.85
<i>BLOEDORN LUMBER CO - Total For WWTP Operations</i>			\$52.85
BLOEDORN LUMBER CO - ALL DEPARTMENTS			\$595.69

BLUE360 MEDIA LLC

BLUE360 MEDIA LLC	Police Administration	PROFESSIONAL SERVICES NOT ELSEWHERE C	\$1,276.28
-------------------	-----------------------	---------------------------------------	------------

BLUE360 MEDIA LLC - Total For Police Administration \$1,276.28

BLUE360 MEDIA LLC - ALL DEPARTMENTS \$1,276.28

BRENNTAG PACIFIC, IN

BRENNTAG PACIFIC, IN Regional Water Operations Ferric Chloride \$15,999.50

BRENNTAG PACIFIC, IN - Total For Regional Water Operations \$15,999.50

BRENNTAG PACIFIC, IN WWTP Operations Ferric delivery on 9/28/22 \$16,311.10

BRENNTAG PACIFIC, IN - Total For WWTP Operations \$16,311.10

BRENNTAG PACIFIC, IN - ALL DEPARTMENTS \$32,310.60

BRIAN'S GO TO SERVIC

BRIAN'S GO TO SERVIC Community Development Mowing service \$219.96

BRIAN'S GO TO SERVIC Community Development Mowing service \$103.52

BRIAN'S GO TO SERVIC Community Development Mowing service \$35.00

BRIAN'S GO TO SERVIC Community Development Mowing service \$124.14

BRIAN'S GO TO SERVIC Community Development Mowing service \$139.52

BRIAN'S GO TO SERVIC Community Development Mowing service \$136.64

BRIAN'S GO TO SERVIC Community Development Mowing service \$172.88

BRIAN'S GO TO SERVIC Community Development Mowing service \$135.90

BRIAN'S GO TO SERVIC Community Development Mowing service \$109.66

BRIAN'S GO TO SERVIC Community Development Mowing service \$82.77

BRIAN'S GO TO SERVIC - Total For Community Development \$1,259.99

BRIAN'S GO TO SERVIC - ALL DEPARTMENTS \$1,259.99

BRIDGEPAY NETWORK SO

BRIDGEPAY NETWORK SO City Clerk CREDIT CARD FEES \$12.86

BRIDGEPAY NETWORK SO - Total For City Clerk \$12.86

BRIDGEPAY NETWORK SO Community Development CREDIT CARD FEES \$12.87

BRIDGEPAY NETWORK SO - Total For Community Development \$12.87

BRIDGEPAY NETWORK SO Engineering CREDIT CARD FEES \$12.87

BRIDGEPAY NETWORK SO - Total For Engineering \$12.87

BRIDGEPAY NETWORK SO - ALL DEPARTMENTS \$38.60

BUSH-WELLS SPORTING

BUSH-WELLS SPORTING	Parks - Parks Maint.	Basketball hoop for PV Park	\$187.95
<i>BUSH-WELLS SPORTING - Total For Parks - Parks Maint.</i>			<i>\$187.95</i>
BUSH-WELLS SPORTING - ALL DEPARTMENTS			\$187.95

CAESARS HOTEL

CAESARS HOTEL	Police Career Services	CAESARS HOTEL AND CASINO	\$516.10
<i>CAESARS HOTEL - Total For Police Career Services</i>			<i>\$516.10</i>
CAESARS HOTEL - ALL DEPARTMENTS			\$516.10

CAMFIL USA INC.

CAMFIL USA INC.	WWTP Operations	Filters	\$1,029.35
CAMFIL USA INC.	WWTP Operations	Filters	\$1,029.35
<i>CAMFIL USA INC. - Total For WWTP Operations</i>			<i>\$2,058.70</i>
CAMFIL USA INC. - ALL DEPARTMENTS			\$2,058.70

CAPITAL BUSINESS SYS

CAPITAL BUSINESS SYS	Fleet Maintenance Fund	Copier usage	\$61.80
<i>CAPITAL BUSINESS SYS - Total For Fleet Maintenance Fund</i>			<i>\$61.80</i>
CAPITAL BUSINESS SYS - ALL DEPARTMENTS			\$61.80

CARL VINSON INST OF

CARL VINSON INST OF	Finance	University of Georgia Class for Christa	\$499.00
<i>CARL VINSON INST OF - Total For Finance</i>			<i>\$499.00</i>
CARL VINSON INST OF - ALL DEPARTMENTS			\$499.00

CAROLINA SOFTWARE

CAROLINA SOFTWARE	Balefill - Disposal & Landfill	Software & Auto-Email Support-Qtr ending 1	\$700.00
<i>CAROLINA SOFTWARE - Total For Balefill - Disposal & Landfill</i>			<i>\$700.00</i>
CAROLINA SOFTWARE - ALL DEPARTMENTS			\$700.00

CARUS CORPORATION

CARUS CORPORATION	Regional Water Operations	Chemicals - Poly-500-55	\$3,159.00
<i>CARUS CORPORATION - Total For Regional Water Operations</i>			<i>\$3,159.00</i>
CARUS CORPORATION - ALL DEPARTMENTS			\$3,159.00

CASELLE, INC.

CASELLE, INC.	Customer Service	Contract Support & Maintenance-11/1/22 to	\$78.00
<i>CASELLE, INC. - Total For Customer Service</i>			<i>\$78.00</i>
CASELLE, INC. - ALL DEPARTMENTS			\$78.00

CASPER AREA CHAMBER

CASPER AREA CHAMBER	City Council	Gold Level Investment	\$600.00
<i>CASPER AREA CHAMBER - Total For City Council</i>			<i>\$600.00</i>
CASPER AREA CHAMBER - ALL DEPARTMENTS			\$600.00

CASPER AREA CONVENTI

CASPER AREA CONVENTI	Social Community Services	Visit Casper Contract for Comm	\$25,000.00
<i>CASPER AREA CONVENTI - Total For Social Community Services</i>			<i>\$25,000.00</i>
CASPER AREA CONVENTI - ALL DEPARTMENTS			\$25,000.00

CASPER NATRONA COUNT

CASPER NATRONA COUNT	Aquatics - Operations	Routine inspection	\$85.00
CASPER NATRONA COUNT	Aquatics - Operations	Routine inspection	\$85.00
CASPER NATRONA COUNT	Aquatics - Operations	Routine inspection	\$85.00
<i>CASPER NATRONA COUNT - Total For Aquatics - Operations</i>			<i>\$255.00</i>
CASPER NATRONA COUNT - ALL DEPARTMENTS			\$255.00

CASPER STAR-TRIBUNE,

CASPER STAR-TRIBUNE,	Capital Projects Fund	Advertising-Notice of Final Payment to Contr	\$223.12
<i>CASPER STAR-TRIBUNE, - Total For Capital Projects Fund</i>			<i>\$223.12</i>
CASPER STAR-TRIBUNE,	Community Development	Advertising - The Planning & Zoning Notice	\$108.96

<i>CASPER STAR-TRIBUNE, - Total For Community Development</i>			<i>\$108.96</i>
CASPER STAR-TRIBUNE,	Finance	Advertising - Notice Per Wyoming State Stat	\$1,566.68
CASPER STAR-TRIBUNE,	Finance	Advertising-Notice of Hearing Amending FY	\$44.12
<i>CASPER STAR-TRIBUNE, - Total For Finance</i>			<i>\$1,610.80</i>
CASPER STAR-TRIBUNE,	Metropolitan Planning Org	Advertising - Request for Proposals	\$84.92
CASPER STAR-TRIBUNE,	Metropolitan Planning Org	Advertising - Request for Proposals	\$86.36
<i>CASPER STAR-TRIBUNE, - Total For Metropolitan Planning Org</i>			<i>\$171.28</i>
CASPER STAR-TRIBUNE,	Regional Water Operations	Advertising - Notice of Budget Hearing	\$384.00
<i>CASPER STAR-TRIBUNE, - Total For Regional Water Operations</i>			<i>\$384.00</i>
CASPER STAR-TRIBUNE, - ALL DEPARTMENTS			\$2,498.16

CASPER TIRE

CASPER TIRE	Balefill - Disposal & Landfill	Flat repair	\$45.00
<i>CASPER TIRE - Total For Balefill - Disposal & Landfill</i>			<i>\$45.00</i>
CASPER TIRE	Fleet Maintenance Fund	ATV flat repair	\$20.00
CASPER TIRE	Fleet Maintenance Fund	Tires	\$440.00
<i>CASPER TIRE - Total For Fleet Maintenance Fund</i>			<i>\$460.00</i>
CASPER TIRE	Refuse - Residential	Flat repair	\$45.00
CASPER TIRE	Refuse - Residential	Flat repair	\$45.00
CASPER TIRE	Refuse - Residential	Flat repair	\$45.00
CASPER TIRE	Refuse - Residential	Flat repair & valve stem	\$55.00
CASPER TIRE	Refuse - Residential	Flat repair	\$90.00
<i>CASPER TIRE - Total For Refuse - Residential</i>			<i>\$280.00</i>
CASPER TIRE - ALL DEPARTMENTS			\$785.00

CASPER WINNELSON CO

CASPER WINNELSON CO	Buildings & Structures Fund	Pool repair equipment for Aquatics Center -	\$70.93
CASPER WINNELSON CO	Buildings & Structures Fund	Plumbing repair supplies for City Hall - Winne	\$38.58
CASPER WINNELSON CO	Buildings & Structures Fund	Plumbing repair supplies for Stuckenhoff Sho	\$18.59
CASPER WINNELSON CO	Buildings & Structures Fund	HVAC repair supplies for Metro Animal Shelt	\$233.79
<i>CASPER WINNELSON CO - Total For Buildings & Structures Fund</i>			<i>\$361.89</i>
CASPER WINNELSON CO - ALL DEPARTMENTS			\$361.89

CEMEX ZIP TRIP099064

CEMEX ZIP TRIP099064	Public Transit - CARES Act	AUTOMATED FUEL DISPENSERS	\$15.00
<i>CEMEX ZIP TRIP099064 - Total For Public Transit - CARES Act</i>			<i>\$15.00</i>
CEMEX ZIP TRIP099064 - ALL DEPARTMENTS			\$15.00

CENTRAL TRUCK & DIES

CENTRAL TRUCK & DIES	Fleet Maintenance Fund	Vehicle repair	\$1,794.19
<i>CENTRAL TRUCK & DIES - Total For Fleet Maintenance Fund</i>			<i>\$1,794.19</i>
CENTRAL TRUCK & DIES - ALL DEPARTMENTS			\$1,794.19

CENTRAL WY. REGIONAL

CENTRAL WY. REGIONAL	Water Administration	Wholesale Water - September 2022	\$939,627.42
<i>CENTRAL WY. REGIONAL - Total For Water Administration</i>			<i>\$939,627.42</i>
CENTRAL WY. REGIONAL	Water Revenue and Transfers System Investment Charges - September 202		\$12,336.00
<i>CENTRAL WY. REGIONAL - Total For Water Revenue and Transfers</i>			<i>\$12,336.00</i>
CENTRAL WY. REGIONAL - ALL DEPARTMENTS			\$951,963.42

CENTURYLINK

CENTURYLINK	Aquatics - Operations	Acct #P-307-111-9950 456M	\$27.93
CENTURYLINK	Aquatics - Operations	Acct #P-307-111-9950 456M	\$27.87
<i>CENTURYLINK - Total For Aquatics - Operations</i>			<i>\$55.80</i>
CENTURYLINK	Balefill - Disposal & Landfill	Acct #P-307-111-9950 456M	\$89.84
CENTURYLINK	Balefill - Disposal & Landfill	Acct #P-307-111-9950 456M	\$89.65
CENTURYLINK	Balefill - Disposal & Landfill	Acct #307-265-4035 606B	\$80.57
<i>CENTURYLINK - Total For Balefill - Disposal & Landfill</i>			<i>\$260.06</i>
CENTURYLINK	Buildings & Structures Fund	Acct #P-307-111-9950 456M	\$16.87
CENTURYLINK	Buildings & Structures Fund	Acct #P-307-111-9950 456M	\$16.90
CENTURYLINK	Buildings & Structures Fund	Acct #307-265-0955 140B	\$44.56
<i>CENTURYLINK - Total For Buildings & Structures Fund</i>			<i>\$78.33</i>
CENTURYLINK	Casper Business Center	Acct #307-577-0851 167B	\$116.14
CENTURYLINK	Casper Business Center	Acct #307-472-4421 865B	\$61.26
CENTURYLINK	Casper Business Center	Acct #307-472-4421 865B	\$78.14
<i>CENTURYLINK - Total For Casper Business Center</i>			<i>\$255.54</i>

CENTURYLINK	Cemetery	Acct #P-307-111-9950 456M	\$16.90
CENTURYLINK	Cemetery	Acct #P-307-111-9950 456M	\$16.87
<i>CENTURYLINK - Total For Cemetery</i>			\$33.77
CENTURYLINK	City Attorney	Acct #P-307-111-9950 456M	\$61.60
CENTURYLINK	City Attorney	Acct #P-307-111-9950 456M	\$61.73
<i>CENTURYLINK - Total For City Attorney</i>			\$123.33
CENTURYLINK	City Council	Acct #P-307-111-9950 456M	\$16.90
CENTURYLINK	City Council	Acct #P-307-111-9950 456M	\$16.87
<i>CENTURYLINK - Total For City Council</i>			\$33.77
CENTURYLINK	City Hall	Acct #P-307-111-9950 456M	\$11.18
CENTURYLINK	City Hall	Acct #P-307-111-9950 456M	\$11.21
<i>CENTURYLINK - Total For City Hall</i>			\$22.39
CENTURYLINK	City Manager	Acct #P-307-111-9950 456M	\$39.32
CENTURYLINK	City Manager	Acct #P-307-111-9950 456M	\$39.23
<i>CENTURYLINK - Total For City Manager</i>			\$78.55
CENTURYLINK	Community Development	Acct #P-307-111-9950 456M	\$134.39
CENTURYLINK	Community Development	Acct #P-307-111-9950 456M	\$134.67
<i>CENTURYLINK - Total For Community Development</i>			\$269.06
CENTURYLINK	Customer Service	Acct #P-307-111-9950 456M	\$39.32
CENTURYLINK	Customer Service	Acct #P-307-111-9950 456M	\$39.23
CENTURYLINK	Customer Service	Acct #307-235-8290 915B	\$49.73
<i>CENTURYLINK - Total For Customer Service</i>			\$128.28
CENTURYLINK	Engineering	Acct #P-307-111-9950 456M	\$78.47
CENTURYLINK	Engineering	Acct #P-307-111-9950 456M	\$78.63
<i>CENTURYLINK - Total For Engineering</i>			\$157.10
CENTURYLINK	Finance	Acct #P-307-111-9950 456M	\$89.84
CENTURYLINK	Finance	Acct #P-307-111-9950 456M	\$89.65
<i>CENTURYLINK - Total For Finance</i>			\$179.49
CENTURYLINK	Fire-EMS Administration	Acct #71332709	\$256.57
CENTURYLINK	Fire-EMS Administration	Acct #307-432-1300 572B	\$500.79
CENTURYLINK	Fire-EMS Administration	Acct #P-307-111-9950 456M	\$112.02
CENTURYLINK	Fire-EMS Administration	Acct #P-307-111-9950 456M	\$112.26
<i>CENTURYLINK - Total For Fire-EMS Administration</i>			\$981.64
CENTURYLINK	Fleet Maintenance Fund	Acct #P-307-111-9950 456M	\$72.94
CENTURYLINK	Fleet Maintenance Fund	Acct #P-307-111-9950 456M	\$72.79
<i>CENTURYLINK - Total For Fleet Maintenance Fund</i>			\$145.73

CENTURYLINK	Ft. Caspar Museum	Acct #P-307-111-9950 456M	\$16.87
CENTURYLINK	Ft. Caspar Museum	Acct #P-307-111-9950 456M	\$16.90
<i>CENTURYLINK - Total For Ft. Caspar Museum</i>			<i>\$33.77</i>
CENTURYLINK	Golf - Operations	Acct #P-307-111-9950 456M	\$16.87
CENTURYLINK	Golf - Operations	Acct #P-307-111-9950 456M	\$16.90
<i>CENTURYLINK - Total For Golf - Operations</i>			<i>\$33.77</i>
CENTURYLINK	Hogadon - Operations	Acct #P-307-111-9950 456M	\$55.92
CENTURYLINK	Hogadon - Operations	Acct #P-307-111-9950 456M	\$56.04
<i>CENTURYLINK - Total For Hogadon - Operations</i>			<i>\$111.96</i>
CENTURYLINK	Human Resources	Acct #P-307-111-9950 456M	\$28.05
CENTURYLINK	Human Resources	Acct #P-307-111-9950 456M	\$28.11
<i>CENTURYLINK - Total For Human Resources</i>			<i>\$56.16</i>
CENTURYLINK	Ice Arena - Operations	Acct #P-307-111-9950 456M	\$22.42
CENTURYLINK	Ice Arena - Operations	Acct #307-235-7540 740B	\$48.48
CENTURYLINK	Ice Arena - Operations	Acct #P-307-111-9950 456M	\$22.37
<i>CENTURYLINK - Total For Ice Arena - Operations</i>			<i>\$93.27</i>
CENTURYLINK	Information Services	Acct #P-307-111-9950 456M	\$89.65
CENTURYLINK	Information Services	Acct #P-307-111-9950 456M	\$89.84
<i>CENTURYLINK - Total For Information Services</i>			<i>\$179.49</i>
CENTURYLINK	Metro Animal Shelter	Acct #P-307-111-9950 456M	\$16.87
CENTURYLINK	Metro Animal Shelter	Acct #P-307-111-9950 456M	\$16.90
<i>CENTURYLINK - Total For Metro Animal Shelter</i>			<i>\$33.77</i>
CENTURYLINK	Municipal Court	Acct #P-307-111-9950 456M	\$61.73
CENTURYLINK	Municipal Court	Acct #P-307-111-9950 456M	\$61.60
<i>CENTURYLINK - Total For Municipal Court</i>			<i>\$123.33</i>
CENTURYLINK	Parks - Parks Maint.	Acct #P-307-111-9950 456M	\$61.60
CENTURYLINK	Parks - Parks Maint.	Acct #P-307-111-9950 456M	\$61.73
<i>CENTURYLINK - Total For Parks - Parks Maint.</i>			<i>\$123.33</i>
CENTURYLINK	Police Administration	Acct #P-307-111-9950 456M	\$347.08
CENTURYLINK	Police Administration	Acct #P-307-111-9950 456M	\$347.80
CENTURYLINK	Police Administration	Acct #P-307-111-5103 060M	\$799.26
<i>CENTURYLINK - Total For Police Administration</i>			<i>\$1,494.14</i>
CENTURYLINK	Public Safety Communication	Acct #P-307-632-4759 643M	\$303.75
CENTURYLINK	Public Safety Communication	Acct #P-307-111-9950 456M	\$11.21
CENTURYLINK	Public Safety Communication	Acct #P-307-111-9950 456M	\$11.18
CENTURYLINK	Public Safety Communication	Acct #P-307-111-5107 160M	\$11,132.38

CENTURYLINK	Public Safety Communication	Acct #307-235-7592 537B	\$217.18
<i>CENTURYLINK - Total For Public Safety Communications</i>			<i>\$11,675.70</i>
CENTURYLINK	Rec Center - Operations	Acct #P-307-111-9950 456M	\$44.74
CENTURYLINK	Rec Center - Operations	Acct #P-307-111-9950 456M	\$44.83
<i>CENTURYLINK - Total For Rec Center - Operations</i>			<i>\$89.57</i>
CENTURYLINK	Regional Water Operations	Acct #P-307-111-9950 456M	\$22.42
CENTURYLINK	Regional Water Operations	Acct #P-307-111-9950 456M	\$22.37
<i>CENTURYLINK - Total For Regional Water Operations</i>			<i>\$44.79</i>
CENTURYLINK	Risk Management	Acct #P-307-111-9950 456M	\$16.89
CENTURYLINK	Risk Management	Acct #P-307-111-9950 456M	\$16.89
<i>CENTURYLINK - Total For Risk Management</i>			<i>\$33.78</i>
CENTURYLINK	Sewer Wastewater Collection	Acct #P-307-111-9950 456M	\$11.21
CENTURYLINK	Sewer Wastewater Collection	Acct #P-307-111-9950 456M	\$11.18
<i>CENTURYLINK - Total For Sewer Wastewater Collection</i>			<i>\$22.39</i>
CENTURYLINK	Streets	Acct #P-307-111-9950 456M	\$39.23
CENTURYLINK	Streets	Acct #P-307-111-9950 456M	\$39.32
<i>CENTURYLINK - Total For Streets</i>			<i>\$78.55</i>
CENTURYLINK	Water Administration	Acct #P-307-111-9950 456M	\$22.42
CENTURYLINK	Water Administration	Acct #P-307-111-9950 456M	\$22.37
<i>CENTURYLINK - Total For Water Administration</i>			<i>\$44.79</i>
CENTURYLINK	Water Distribution	Acct #P-307-111-9950 456M	\$16.87
CENTURYLINK	Water Distribution	Acct #P-307-111-9950 456M	\$16.90
<i>CENTURYLINK - Total For Water Distribution</i>			<i>\$33.77</i>
CENTURYLINK	Water Meters	Acct #P-307-111-9950 456M	\$33.45
CENTURYLINK	Water Meters	Acct #P-307-111-9950 456M	\$33.38
<i>CENTURYLINK - Total For Water Meters</i>			<i>\$66.83</i>
CENTURYLINK	WWTP Operations	Acct #P-307-111-9950 456M	\$33.62
CENTURYLINK	WWTP Operations	Acct #P-307-111-9950 456M	\$33.55
<i>CENTURYLINK - Total For WWTP Operations</i>			<i>\$67.17</i>
CENTURYLINK - ALL DEPARTMENTS			\$17,243.17

CHALK BUTTES LANDSCA

CHALK BUTTES LANDSCA	Capital Projects Fund	2022 Highland Park Cemetery Ir	\$56,169.90
<i>CHALK BUTTES LANDSCA - Total For Capital Projects Fund</i>			<i>\$56,169.90</i>
CHALK BUTTES LANDSCA	Water Revenue and Transfers Retainage - Contract #23300009		\$2,956.31

CHALK BUTTES LANDSCA - Total For Water Revenue and Transfers	\$2,956.31
--	------------

CHALK BUTTES LANDSCA - ALL DEPARTMENTS	\$59,126.21
---	--------------------

CHEM AQUA

CHEM AQUA	Ice Arena - Operations	Chem Aqua Water Treatment	\$489.83
-----------	------------------------	---------------------------	----------

CHEM AQUA - Total For Ice Arena - Operations	\$489.83
--	----------

CHEM AQUA - ALL DEPARTMENTS	\$489.83
------------------------------------	-----------------

CHEYENNE COUNTRY CLU

CHEYENNE COUNTRY CLU	Fire-EMS Training	Meal while in Cheyenne for RERT2 Meeting	\$22.68
----------------------	-------------------	--	---------

CHEYENNE COUNTRY CLU - Total For Fire-EMS Training	\$22.68
--	---------

CHEYENNE COUNTRY CLU - ALL DEPARTMENTS	\$22.68
---	----------------

CHICK-FIL-A #03335

CHICK-FIL-A #03335	Police Administration	FAST FOOD RESTAURANTS	\$9.64
--------------------	-----------------------	-----------------------	--------

CHICK-FIL-A #03335 - Total For Police Administration	\$9.64
--	--------

CHICK-FIL-A #03335 - ALL DEPARTMENTS	\$9.64
---	---------------

CHICK-FIL-A #03336

CHICK-FIL-A #03336	Police Investigations	FAST FOOD RESTAURANTS	\$18.69
--------------------	-----------------------	-----------------------	---------

CHICK-FIL-A #03336 - Total For Police Investigations	\$18.69
--	---------

CHICK-FIL-A #03336 - ALL DEPARTMENTS	\$18.69
---	----------------

CHIPOTLE 1014

CHIPOTLE 1014	Police Administration	FAST FOOD RESTAURANTS	\$29.68
---------------	-----------------------	-----------------------	---------

CHIPOTLE 1014 - Total For Police Administration	\$29.68
---	---------

CHIPOTLE 1014 - ALL DEPARTMENTS	\$29.68
--	----------------

CITIZEN PAYMENT

CITIZEN PAYMENT	Rec Center	Refund-Fall Ball Tournament field use (Sunda	\$225.00
-----------------	------------	--	----------

CITIZEN PAYMENT - Total For Rec Center	\$225.00
--	----------

CITIZEN PAYMENT - ALL DEPARTMENTS

\$225.00

CITRIX SYSTEMS INC.

CITRIX SYSTEMS INC.	Community Development	Citrix Renewal for Building Inspections	\$871.40
---------------------	-----------------------	---	----------

<i>CITRIX SYSTEMS INC. - Total For Community Development</i>			\$871.40
--	--	--	----------

CITRIX SYSTEMS INC. - ALL DEPARTMENTS

\$871.40

CITY OF CASPER

CITY OF CASPER	Hogadon - Operations	Public Garbage Baler	\$20.00
----------------	----------------------	----------------------	---------

CITY OF CASPER	Hogadon - Operations	Public Garbage	\$20.00
----------------	----------------------	----------------	---------

<i>CITY OF CASPER - Total For Hogadon - Operations</i>			\$40.00
--	--	--	---------

CITY OF CASPER	Metropolitan Planning Org	GIS - Interdepartmental Services	\$6,655.37
----------------	---------------------------	----------------------------------	------------

<i>CITY OF CASPER - Total For Metropolitan Planning Org</i>			\$6,655.37
---	--	--	------------

CITY OF CASPER	Parks - Parks Maint.	Public Garbage	\$160.38
----------------	----------------------	----------------	----------

<i>CITY OF CASPER - Total For Parks - Parks Maint.</i>			\$160.38
--	--	--	----------

CITY OF CASPER	Refuse - Residential	Private commercial charge	\$54,680.00
----------------	----------------------	---------------------------	-------------

CITY OF CASPER	Refuse - Residential	Garbage baler & recycled newspaper/cardbo	\$6,973.58
----------------	----------------------	---	------------

CITY OF CASPER	Refuse - Residential	Public Garbage-Baler & Recycled Cardboard	\$522.72
----------------	----------------------	---	----------

CITY OF CASPER	Refuse - Residential	Garbage baler, recycled newspaper/cardboard	\$6,617.72
----------------	----------------------	---	------------

CITY OF CASPER	Refuse - Residential	Garbage baler & recycled newspaper/cardbo	\$6,587.48
----------------	----------------------	---	------------

CITY OF CASPER	Refuse - Residential	Garbage baler & recycled cardboard	\$581.04
----------------	----------------------	------------------------------------	----------

CITY OF CASPER	Refuse - Residential	Garbage baler, recycled newspaper & cardbo	\$7,313.76
----------------	----------------------	--	------------

CITY OF CASPER	Refuse - Residential	Garbage baler & recycled cardboard	\$6,916.32
----------------	----------------------	------------------------------------	------------

CITY OF CASPER	Refuse - Residential	Garbage baler & recycled cardboard	\$6,570.72
----------------	----------------------	------------------------------------	------------

CITY OF CASPER	Refuse - Residential	Garbage baler/street sweeping/newspaper/c	\$14,838.66
----------------	----------------------	---	-------------

CITY OF CASPER	Refuse - Residential	Garbage baler, recycled newspaper/cardboard	\$6,899.04
----------------	----------------------	---	------------

CITY OF CASPER	Refuse - Residential	Garbage baler, street sweepings, recycle car	\$6,637.16
----------------	----------------------	--	------------

CITY OF CASPER	Refuse - Residential	Garbage baler & recycled cardboard	\$6,410.34
----------------	----------------------	------------------------------------	------------

CITY OF CASPER	Refuse - Residential	Street Sweeping	\$2,266.00
----------------	----------------------	-----------------	------------

CITY OF CASPER	Refuse - Residential	Garbage baler & recycled cardboard	\$6,907.14
----------------	----------------------	------------------------------------	------------

CITY OF CASPER	Refuse - Residential	Garbage baler, recycled newspaper/cardboard	\$6,975.18
----------------	----------------------	---	------------

<i>CITY OF CASPER - Total For Refuse - Residential</i>			\$147,696.86
--	--	--	--------------

CITY OF CASPER	WWTP Operations	Sump Sludge/Honey Wagon	\$95.04
----------------	-----------------	-------------------------	---------

CITY OF CASPER	WWTP Operations	Sump Sludge/Honey Wagon	\$95.04
----------------	-----------------	-------------------------	---------

CITY OF CASPER	WWTP Operations	Sump Sludge/Honey Wagon	\$94.50
<i>CITY OF CASPER - Total For WWTP Operations</i>			<i>\$284.58</i>
CITY OF CASPER - ALL DEPARTMENTS			\$154,837.19

CIVIL ENGINEERING PR

CIVIL ENGINEERING PR	Metropolitan Planning Org	Evansville East Side Sidewalk	\$1,995.00
<i>CIVIL ENGINEERING PR - Total For Metropolitan Planning Org</i>			<i>\$1,995.00</i>
CIVIL ENGINEERING PR - ALL DEPARTMENTS			\$1,995.00

CLH ASSOCIATES LLC

CLH ASSOCIATES LLC	General Fund Revenue	Traffic Impact Study	\$5,300.00
<i>CLH ASSOCIATES LLC - Total For General Fund Revenue</i>			<i>\$5,300.00</i>
CLH ASSOCIATES LLC - ALL DEPARTMENTS			\$5,300.00

CMI TECO, INC.

CMI TECO, INC.	Refuse - Commercial	Equipment repair	\$407.45
CMI TECO, INC.	Refuse - Commercial	Equipment repair	\$2,244.17
CMI TECO, INC.	Refuse - Commercial	Frontloader Trash Truck Replacement	\$222,697.00
<i>CMI TECO, INC. - Total For Refuse - Commercial</i>			<i>\$225,348.62</i>
CMI TECO, INC.	Refuse - Recycling	Equipment repair	\$1,556.77
CMI TECO, INC.	Refuse - Recycling	Equipment repair	\$2,743.48
<i>CMI TECO, INC. - Total For Refuse - Recycling</i>			<i>\$4,300.25</i>
CMI TECO, INC.	Refuse - Residential	Return of drivers seat	(\$883.21)
CMI TECO, INC.	Refuse - Residential	Equipment repair	\$566.53
CMI TECO, INC.	Refuse - Residential	Equipment repair	\$3,061.14
CMI TECO, INC.	Refuse - Residential	Equipment repair	\$515.21
CMI TECO, INC.	Refuse - Residential	Equipment repair	\$4,306.17
CMI TECO, INC.	Refuse - Residential	Equipment repair	\$870.03
CMI TECO, INC.	Refuse - Residential	Equipment repair	\$3,326.30
CMI TECO, INC.	Refuse - Residential	Equipment repair	\$2,037.85
CMI TECO, INC.	Refuse - Residential	Equipment repair	\$4,107.83
CMI TECO, INC.	Refuse - Residential	Hydraulic flush labor billed twice	(\$450.00)
CMI TECO, INC.	Refuse - Residential	Equipment repair	\$400.72

CMI TECO, INC.	Refuse - Residential	Equipment supplies/parts	\$883.21
<i>CMI TECO, INC. - Total For Refuse - Residential</i>			<i>\$18,741.78</i>
CMI TECO, INC. - ALL DEPARTMENTS			\$248,390.65

COASTAL CHEMICAL CO

COASTAL CHEMICAL CO	Regional Water Operations	Unleaded fuel	\$83.97
<i>COASTAL CHEMICAL CO - Total For Regional Water Operations</i>			<i>\$83.97</i>
COASTAL CHEMICAL CO - ALL DEPARTMENTS			\$83.97

COCA COLA BOTTLING C

COCA COLA BOTTLING C	Balefill - Disposal & Landfill	Water delivery	\$24.75
<i>COCA COLA BOTTLING C - Total For Balefill - Disposal & Landfill</i>			<i>\$24.75</i>
COCA COLA BOTTLING C - ALL DEPARTMENTS			\$24.75

COMMISSION ON ACCRED

COMMISSION ON ACCRED	Police Career Services	MEMBERSHIP ORGANIZATIONS NOT ELSEWH	\$1,550.00
<i>COMMISSION ON ACCRED - Total For Police Career Services</i>			<i>\$1,550.00</i>
COMMISSION ON ACCRED	Public Safety Communication	MEMBERSHIP ORGANIZATIONS NOT ELSEWH	\$775.00
<i>COMMISSION ON ACCRED - Total For Public Safety Communications</i>			<i>\$775.00</i>
COMMISSION ON ACCRED - ALL DEPARTMENTS			\$2,325.00

COMMUNICATION TECHNO

COMMUNICATION TECHNO	Police Administration	Repair DVR, battery breakers & battery separ	\$110.00
COMMUNICATION TECHNO	Police Administration	Antenna	\$97.99
<i>COMMUNICATION TECHNO - Total For Police Administration</i>			<i>\$207.99</i>
COMMUNICATION TECHNO	WWTP Regional Interceptors	Installation of SCADA antenna	\$1,047.50
<i>COMMUNICATION TECHNO - Total For WWTP Regional Interceptors</i>			<i>\$1,047.50</i>
COMMUNICATION TECHNO - ALL DEPARTMENTS			\$1,255.49

COMTRONIX, INC.

COMTRONIX, INC.	Balefill - Diversion & Special	Installation of data wall box	\$557.60
<i>COMTRONIX, INC. - Total For Balefill - Diversion & Special</i>			<i>\$557.60</i>

COMTRONIX, INC. - ALL DEPARTMENTS \$557.60

CONOCO - STOP-N-GO

CONOCO - STOP-N-GO Fire-EMS Operations Diesel fuel for E2 \$75.67

CONOCO - STOP-N-GO - Total For Fire-EMS Operations \$75.67

CONOCO - STOP-N-GO - ALL DEPARTMENTS \$75.67

CONVERGEONE

CONVERGEONE Public Safety Communication MCV Network Switch \$1,479.92

CONVERGEONE - Total For Public Safety Communications \$1,479.92

CONVERGEONE - ALL DEPARTMENTS \$1,479.92

CONVERGEONE INC

CONVERGEONE INC Information Services TELECOMMUNICATION EQUIPMENT INCLUD \$10.00

CONVERGEONE INC - Total For Information Services \$10.00

CONVERGEONE INC - ALL DEPARTMENTS \$10.00

COURTYARD BY MARRIOT

COURTYARD BY MARRIOT Police Career Services COURTYARD INNS \$285.42

COURTYARD BY MARRIOT Police Career Services COURTYARD INNS \$146.48

COURTYARD BY MARRIOT - Total For Police Career Services \$431.90

COURTYARD BY MARRIOT - ALL DEPARTMENTS \$431.90

COWBOY SUPPLY HOUSE

COWBOY SUPPLY HOUSE Buildings & Structures Fund Trash Bags \$163.47

COWBOY SUPPLY HOUSE Buildings & Structures Fund CRC Laundry Detergent \$134.36

COWBOY SUPPLY HOUSE - Total For Buildings & Structures Fund \$297.83

COWBOY SUPPLY HOUSE - ALL DEPARTMENTS \$297.83

CPI ENVIRONMENTALEXP

CPI ENVIRONMENTALEXP WWTP Operations Lab supplies \$157.60

CPI ENVIRONMENTALEXP - Total For WWTP Operations \$157.60

CPI ENVIRONMENTALEXP - ALL DEPARTMENTS \$157.60

CPU IIT

CPU IIT City Attorney Computer/Electronic supplies \$100.09

CPU IIT - Total For City Attorney \$100.09

CPU IIT Risk Management Wall Mount Rack \$1,580.00

CPU IIT - Total For Risk Management \$1,580.00

CPU IIT - ALL DEPARTMENTS \$1,680.09

CREATOPY FREETRIA

CREATOPY FREETRIA City Manager Creatopy subscription \$32.00

CREATOPY FREETRIA - Total For City Manager \$32.00

CREATOPY FREETRIA - ALL DEPARTMENTS \$32.00

CRESCENT ELECTRIC SU

CRESCENT ELECTRIC SU Buildings & Structures Fund Lighting repair supplies for Service Center - C \$45.87

CRESCENT ELECTRIC SU - Total For Buildings & Structures Fund \$45.87

CRESCENT ELECTRIC SU Parks - Parks Maint. Electrical repair at Wells Shelter 1 \$29.01

CRESCENT ELECTRIC SU - Total For Parks - Parks Maint. \$29.01

CRESCENT ELECTRIC SU Water Meters 3-WIRE BUTT SPLICE JELLYBEAN ERT PARTS - \$53.63

CRESCENT ELECTRIC SU - Total For Water Meters \$53.63

CRESCENT ELECTRIC SU - ALL DEPARTMENTS \$128.51

CRUM ELECTRIC SUPPLY

CRUM ELECTRIC SUPPLY Buildings & Structures Fund Lighting repair supplies for Service Center - C \$347.58

CRUM ELECTRIC SUPPLY Buildings & Structures Fund Lighting supplies for Metro Animal Shelter - \$6.46

CRUM ELECTRIC SUPPLY - Total For Buildings & Structures Fund \$354.04

CRUM ELECTRIC SUPPLY Parks - Parks Maint. Electrical repair at Wells Shelter 1 \$46.41

CRUM ELECTRIC SUPPLY - Total For Parks - Parks Maint. \$46.41

CRUM ELECTRIC SUPPLY Regional Water Operations Parts for Actiflo Train #1 Sump Pump - Pump \$120.19

CRUM ELECTRIC SUPPLY Regional Water Operations Supplies & Parts to Rewire Exhaust Fan Moto \$87.78

CRUM ELECTRIC SUPPLY - Total For Regional Water Operations \$207.97

CRUM ELECTRIC SUPPLY	Traffic Control	Photo cells for luminaire repair	\$94.84
<i>CRUM ELECTRIC SUPPLY - Total For Traffic Control</i>			<i>\$94.84</i>
CRUM ELECTRIC SUPPLY - ALL DEPARTMENTS			\$703.26

CURB APPEAL PAINTING

CURB APPEAL PAINTING	Capital Projects Fund	Staining of lodge exterior beams and ceiling	\$9,900.00
<i>CURB APPEAL PAINTING - Total For Capital Projects Fund</i>			<i>\$9,900.00</i>
CURB APPEAL PAINTING - ALL DEPARTMENTS			\$9,900.00

DALCO INDUSTRIES INC

DALCO INDUSTRIES INC	Water Distribution	Rebar	\$330.00
<i>DALCO INDUSTRIES INC - Total For Water Distribution</i>			<i>\$330.00</i>
DALCO INDUSTRIES INC - ALL DEPARTMENTS			\$330.00

DANA KEPNER COMPANY

DANA KEPNER COMPANY	RWS - Booster Stations	Valves & Boxes for Regional Boosters - Boost	\$1,961.11
DANA KEPNER COMPANY	RWS - Booster Stations	Anodes Regional Booster Stations - Booster S	\$1,136.38
DANA KEPNER COMPANY	RWS - Booster Stations	Plugs & Bolts for Regional Booster Supplies	\$1,327.05
<i>DANA KEPNER COMPANY - Total For RWS - Booster Stations</i>			<i>\$4,424.54</i>
DANA KEPNER COMPANY	Water Distribution	Blade for Walk Behind 12" Saw / Water & Se	\$164.29
DANA KEPNER COMPANY	Water Distribution	6" Clamps & Couplings - Water & Sewerline	\$1,496.70
DANA KEPNER COMPANY	Water Distribution	8" Clamps Water & Sewerline Materials	\$1,520.95
DANA KEPNER COMPANY	Water Distribution	Singer Parts - Water & Sewerline Materials	\$549.10
DANA KEPNER COMPANY	Water Distribution	8" MJ Caps & Parts - Water & Sewerline Mat	\$1,261.40
DANA KEPNER COMPANY	Water Distribution	3/4" Comp Curb Stop - Water & Sewerline M	\$1,957.00
DANA KEPNER COMPANY	Water Distribution	CLA-VAL 14200A REPAIR KIT FOR PILOT - GOL	\$545.00
<i>DANA KEPNER COMPANY - Total For Water Distribution</i>			<i>\$7,494.44</i>
DANA KEPNER COMPANY - ALL DEPARTMENTS			\$11,918.98

DAYS INNS/DAYSTOP

DAYS INNS/DAYSTOP	Police State Grants	DAYS INNS	\$60.00
<i>DAYS INNS/DAYSTOP - Total For Police State Grants</i>			<i>\$60.00</i>

DAYS INNS/DAYSTOP - ALL DEPARTMENTS \$60.00

DBC IRRIGATION SUPPL

DBC IRRIGATION SUPPL	Parks - Athletic Maint.	Irrigation flags for Aeration	\$113.32
<i>DBC IRRIGATION SUPPL - Total For Parks - Athletic Maint.</i>			\$113.32
DBC IRRIGATION SUPPL	Parks - Parks Maint.	Hose clamp for fountain at roundabout	\$3.55
DBC IRRIGATION SUPPL	Parks - Parks Maint.	Irrigation repair Highland Park	\$47.33
DBC IRRIGATION SUPPL	Parks - Parks Maint.	Irrigation repair Highland Park	\$97.32
DBC IRRIGATION SUPPL	Parks - Parks Maint.	Irrigation repair Highland Park	\$89.83
DBC IRRIGATION SUPPL	Parks - Parks Maint.	Irrigation repair Bryan Stock	\$44.75
DBC IRRIGATION SUPPL	Parks - Parks Maint.	Parts to repair irrigation at rescue mission bu	\$59.88
<i>DBC IRRIGATION SUPPL - Total For Parks - Parks Maint.</i>			\$342.66
DBC IRRIGATION SUPPL	Public Transit - Operations	Parts to repair irrigation at rescue mission bu	\$6.62
<i>DBC IRRIGATION SUPPL - Total For Public Transit - Operations</i>			\$6.62
DBC IRRIGATION SUPPL - ALL DEPARTMENTS			\$462.60

DEACONS RESTAURANT

DEACONS RESTAURANT	Police Investigations	EATING PLACES, RESTAURANTS	\$39.42
<i>DEACONS RESTAURANT - Total For Police Investigations</i>			\$39.42
DEACONS RESTAURANT - ALL DEPARTMENTS			\$39.42

DECKER AUTO GLASS, I

DECKER AUTO GLASS, I	Fleet Maintenance Fund	Auto glass repair	\$315.00
<i>DECKER AUTO GLASS, I - Total For Fleet Maintenance Fund</i>			\$315.00
DECKER AUTO GLASS, I	Refuse - Commercial	Windshield repair	\$216.13
<i>DECKER AUTO GLASS, I - Total For Refuse - Commercial</i>			\$216.13
DECKER AUTO GLASS, I	Refuse - Residential	Cleaner	\$193.50
<i>DECKER AUTO GLASS, I - Total For Refuse - Residential</i>			\$193.50
DECKER AUTO GLASS, I - ALL DEPARTMENTS			\$724.63

DELL MARKETING LP

DELL MARKETING LP	Engineering	Adobe Subscription Engineering Associate	\$172.47
<i>DELL MARKETING LP - Total For Engineering</i>			\$172.47

DELL MARKETING LP	Finance	Adobe License - For Christa	\$172.47
<i>DELL MARKETING LP - Total For Finance</i>			<i>\$172.47</i>
DELL MARKETING LP - ALL DEPARTMENTS			\$344.94

DELTA 0062340771

DELTA 0062340771	Police Career Services	DELTA	\$428.20
<i>DELTA 0062340771 - Total For Police Career Services</i>			<i>\$428.20</i>
DELTA 0062340771 - ALL DEPARTMENTS			\$428.20

DELTA 0062340929

DELTA 0062340929	Police Career Services	DELTA	\$428.20
<i>DELTA 0062340929 - Total For Police Career Services</i>			<i>\$428.20</i>
DELTA 0062340929 - ALL DEPARTMENTS			\$428.20

DELTA 0062340998

DELTA 0062340998	Police Career Services	DELTA	\$428.20
<i>DELTA 0062340998 - Total For Police Career Services</i>			<i>\$428.20</i>
DELTA 0062340998 - ALL DEPARTMENTS			\$428.20

DELTA BY MARRIOTT

DELTA BY MARRIOTT	Fire-EMS Training	Hotel for Garrett Crotty to attend a class	\$312.78
<i>DELTA BY MARRIOTT - Total For Fire-EMS Training</i>			<i>\$312.78</i>
DELTA BY MARRIOTT - ALL DEPARTMENTS			\$312.78

DENNIS SUPPLY CO.

DENNIS SUPPLY CO.	Buildings & Structures Fund	HVAC PM Supplies for Aquatics Center - Den	\$207.22
DENNIS SUPPLY CO.	Buildings & Structures Fund	HVAC supplies for Metro Animal Shelter - De	\$33.96
DENNIS SUPPLY CO.	Buildings & Structures Fund	HVAC PM Supplies for Ice Arena - Dennis Sup	\$47.20
DENNIS SUPPLY CO.	Buildings & Structures Fund	HVAC PM Supplies for Metro Animal Shelter	\$9.77
<i>DENNIS SUPPLY CO. - Total For Buildings & Structures Fund</i>			<i>\$298.15</i>
DENNIS SUPPLY CO. - ALL DEPARTMENTS			\$298.15

DENVER INDUSTRIAL PU

DENVER INDUSTRIAL PU	WWTP Operations	Freight	\$97.17
<i>DENVER INDUSTRIAL PU - Total For WWTP Operations</i>			<i>\$97.17</i>
DENVER INDUSTRIAL PU - ALL DEPARTMENTS			\$97.17

DESERT MTN. CORP.

DESERT MTN. CORP.	Streets	Ice Slicer for 2023	\$3,511.12
<i>DESERT MTN. CORP. - Total For Streets</i>			<i>\$3,511.12</i>
DESERT MTN. CORP. - ALL DEPARTMENTS			\$3,511.12

DOMINO'S 6040

DOMINO'S 6040	Police Administration	FAST FOOD RESTAURANTS	\$50.32
<i>DOMINO'S 6040 - Total For Police Administration</i>			<i>\$50.32</i>
DOMINO'S 6040 - ALL DEPARTMENTS			\$50.32

DOMINO'S 6042

DOMINO'S 6042	Community Development	Food for Homeless meeting	\$147.09
<i>DOMINO'S 6042 - Total For Community Development</i>			<i>\$147.09</i>
DOMINO'S 6042	Police Investigations	FAST FOOD RESTAURANTS	\$37.72
<i>DOMINO'S 6042 - Total For Police Investigations</i>			<i>\$37.72</i>
DOMINO'S 6042 - ALL DEPARTMENTS			\$184.81

DOUBLETREE HOTELS

DOUBLETREE HOTELS	Public Transit - CARES Act	DOUBLETREE	\$211.36
<i>DOUBLETREE HOTELS - Total For Public Transit - CARES Act</i>			<i>\$211.36</i>
DOUBLETREE HOTELS - ALL DEPARTMENTS			\$211.36

DPC INDUSTRIES, INC.

DPC INDUSTRIES, INC.	Regional Water Operations	Sodium Hypochlorite	\$11,436.55
DPC INDUSTRIES, INC.	Regional Water Operations	Sodium Hypochlorite	\$11,492.86
<i>DPC INDUSTRIES, INC. - Total For Regional Water Operations</i>			<i>\$22,929.41</i>

DPC INDUSTRIES, INC. - ALL DEPARTMENTS

\$22,929.41

DREAMSEATS, LLC

DREAMSEATS, LLC	Fire-EMS Operations	New Chairs for Station 1 and Station 3	\$10,872.46
-----------------	---------------------	--	-------------

<i>DREAMSEATS, LLC - Total For Fire-EMS Operations</i>			\$10,872.46
--	--	--	-------------

DREAMSEATS, LLC - ALL DEPARTMENTS

\$10,872.46

DRIVER CHECK

DRIVER CHECK	Balefill - Disposal & Landfill	How's My Driving Safety Srvc - 5/14/22 to 5/	\$47.04
--------------	--------------------------------	--	---------

<i>DRIVER CHECK - Total For Balefill - Disposal & Landfill</i>			\$47.04
--	--	--	---------

DRIVER CHECK	Refuse - Commercial	How's My Driving Safety Srvc - 5/14/22 to 5/	\$172.48
--------------	---------------------	--	----------

<i>DRIVER CHECK - Total For Refuse - Commercial</i>			\$172.48
---	--	--	----------

DRIVER CHECK	Refuse - Recycling	How's My Driving Safety Srvc - 5/14/22 to 5/	\$31.36
--------------	--------------------	--	---------

<i>DRIVER CHECK - Total For Refuse - Recycling</i>			\$31.36
--	--	--	---------

DRIVER CHECK	Refuse - Residential	How's My Driving Safety Srvc - 5/14/22 to 5/	\$360.64
--------------	----------------------	--	----------

<i>DRIVER CHECK - Total For Refuse - Residential</i>			\$360.64
--	--	--	----------

DRIVER CHECK - ALL DEPARTMENTS

\$611.52

DYNAMIC CONTROLS INC

DYNAMIC CONTROLS INC	Police Administration	DETECTIVE AGENCIES & PROTECTIVE AGENC	\$1,960.00
----------------------	-----------------------	---------------------------------------	------------

<i>DYNAMIC CONTROLS INC - Total For Police Administration</i>			\$1,960.00
---	--	--	------------

DYNAMIC CONTROLS INC - ALL DEPARTMENTS

\$1,960.00

EDEN K-9 CONSULTING

EDEN K-9 CONSULTING	Police Administration	Annual K9 Consulting & Training Srvc	\$696.00
---------------------	-----------------------	--------------------------------------	----------

<i>EDEN K-9 CONSULTING - Total For Police Administration</i>			\$696.00
--	--	--	----------

EDEN K-9 CONSULTING - ALL DEPARTMENTS

\$696.00

EMPLOYEE REIMBURSEME

EMPLOYEE REIMBURSEME	Balefill - Diversion & Special	Work clothing reimbursement	\$115.48
----------------------	--------------------------------	-----------------------------	----------

<i>EMPLOYEE REIMBURSEME - Total For Balefill - Diversion & Special</i>			\$115.48
--	--	--	----------

EMPLOYEE REIMBURSEME	Buildings & Structures Fund	Work clothing reimbursement	\$100.00
----------------------	-----------------------------	-----------------------------	----------

EMPLOYEE REIMBURSEME	Buildings & Structures Fund	Work boot reimbursement	\$80.28
<i>EMPLOYEE REIMBURSEME - Total For Buildings & Structures Fund</i>			<i>\$180.28</i>
EMPLOYEE REIMBURSEME	Fleet Maintenance Fund	Work tool allotment reimbursement	\$77.62
EMPLOYEE REIMBURSEME	Fleet Maintenance Fund	Work boot reimbursement	\$150.00
EMPLOYEE REIMBURSEME	Fleet Maintenance Fund	Notary renewal application reimbursement	\$60.00
<i>EMPLOYEE REIMBURSEME - Total For Fleet Maintenance Fund</i>			<i>\$287.62</i>
EMPLOYEE REIMBURSEME	Planning	Quarterly Rotary Dues Reimbursement	\$240.50
<i>EMPLOYEE REIMBURSEME - Total For Planning</i>			<i>\$240.50</i>
EMPLOYEE REIMBURSEME	Police Administration	Reimbursement-Power Cord & HDMI Cable	\$37.78
<i>EMPLOYEE REIMBURSEME - Total For Police Administration</i>			<i>\$37.78</i>
EMPLOYEE REIMBURSEME	Police Career Services	Work clothing reimbursement	\$76.32
EMPLOYEE REIMBURSEME	Police Career Services	Work clothing reimbursement	\$51.96
EMPLOYEE REIMBURSEME	Police Career Services	Work clothing reimbursement	\$441.46
<i>EMPLOYEE REIMBURSEME - Total For Police Career Services</i>			<i>\$569.74</i>
EMPLOYEE REIMBURSEME	Refuse - Residential	Work boot reimbursement	\$150.00
<i>EMPLOYEE REIMBURSEME - Total For Refuse - Residential</i>			<i>\$150.00</i>
EMPLOYEE REIMBURSEME	Regional Water Operations	Notary Public Application Reimbursement	\$60.00
<i>EMPLOYEE REIMBURSEME - Total For Regional Water Operations</i>			<i>\$60.00</i>
EMPLOYEE REIMBURSEME	Water Distribution	Work boot reimbursement	\$111.59
EMPLOYEE REIMBURSEME	Water Distribution	Work clothing reimbursement	\$131.15
<i>EMPLOYEE REIMBURSEME - Total For Water Distribution</i>			<i>\$242.74</i>
EMPLOYEE REIMBURSEME	WWTP Operations	WWTP Level 1 Exam Fee Reimbursement	\$100.00
<i>EMPLOYEE REIMBURSEME - Total For WWTP Operations</i>			<i>\$100.00</i>
EMPLOYEE REIMBURSEME - ALL DEPARTMENTS			\$1,984.14

EMPLOYERS COUNCIL

EMPLOYERS COUNCIL	Customer Service	Finance and customer service training	\$1,424.72
<i>EMPLOYERS COUNCIL - Total For Customer Service</i>			<i>\$1,424.72</i>
EMPLOYERS COUNCIL	Finance	Finance and customer service training	\$1,424.73
<i>EMPLOYERS COUNCIL - Total For Finance</i>			<i>\$1,424.73</i>
EMPLOYERS COUNCIL - ALL DEPARTMENTS			\$2,849.45

ENERGY LABORATORIES

ENERGY LABORATORIES	Fire-EMS Operations	Breathing air samples for St. 1 and 6 compre	\$152.00
---------------------	---------------------	--	----------

ENERGY LABORATORIES - Total For Fire-EMS Operations \$152.00

ENERGY LABORATORIES - ALL DEPARTMENTS \$152.00

ENERGY LABRATORIES I

ENERGY LABRATORIES I Regional Water Operations Aerobic Endospores testing \$306.00

ENERGY LABRATORIES I Regional Water Operations Bacteria, Public Water Supply testing \$52.00

ENERGY LABRATORIES I - Total For Regional Water Operations \$358.00

ENERGY LABRATORIES I Water Tanks Bacteria, SDWA Testing \$52.00

ENERGY LABRATORIES I Water Tanks Bacteria, SDWA Testing \$52.00

ENERGY LABRATORIES I Water Tanks Bacteria, SDWA Testing \$52.00

ENERGY LABRATORIES I Water Tanks Bacteria, SDWA testing \$52.00

ENERGY LABRATORIES I Water Tanks Bacteria, Public Water Supply testing \$320.00

ENERGY LABRATORIES I Water Tanks Bacteria, Public Water Supply testing \$512.00

ENERGY LABRATORIES I - Total For Water Tanks \$1,040.00

ENERGY LABRATORIES I - ALL DEPARTMENTS \$1,398.00

ENGINEERING DESIGN A

ENGINEERING DESIGN A Capital Projects Fund Design of Athletic Fields Ligh \$1,562.50

ENGINEERING DESIGN A - Total For Capital Projects Fund \$1,562.50

ENGINEERING DESIGN A - ALL DEPARTMENTS \$1,562.50

EPOLICESUPPLY.COM

EPOLICESUPPLY.COM Police Administration MISCELLANEOUS AND RETAIL STORES \$256.09

EPOLICESUPPLY.COM - Total For Police Administration \$256.09

EPOLICESUPPLY.COM - ALL DEPARTMENTS \$256.09

EXPERIAN EXP PAY CC

EXPERIAN EXP PAY CC Police Career Services BUSINESS SERVICES NOT ELSEWHERE CLASSI \$511.51

EXPERIAN EXP PAY CC - Total For Police Career Services \$511.51

EXPERIAN EXP PAY CC - ALL DEPARTMENTS \$511.51

EXPRESS SERVICES INC

EXPRESS SERVICES INC	Customer Service	Temp service	\$344.25
<i>EXPRESS SERVICES INC - Total For Customer Service</i>			<i>\$344.25</i>
EXPRESS SERVICES INC - ALL DEPARTMENTS			\$344.25

EXXONMOBIL

EXXONMOBIL	Fire-EMS Operations	Fuel for 6s	\$75.84
EXXONMOBIL	Fire-EMS Operations	Fuel	\$135.00
EXXONMOBIL	Fire-EMS Operations	Fuel	\$47.63
EXXONMOBIL	Fire-EMS Operations	Fuel	\$40.17
EXXONMOBIL	Fire-EMS Operations	Fuel	\$45.29
EXXONMOBIL	Fire-EMS Operations	Fuel	\$99.99
EXXONMOBIL	Fire-EMS Operations	Fuel	\$54.04
EXXONMOBIL	Fire-EMS Operations	Fuel	\$99.99
EXXONMOBIL	Fire-EMS Operations	Fuel for E6	\$29.08
<i>EXXONMOBIL - Total For Fire-EMS Operations</i>			<i>\$627.03</i>
EXXONMOBIL	Public Transit - CARES Act	AUTOMATED FUEL DISPENSERS	\$40.66
<i>EXXONMOBIL - Total For Public Transit - CARES Act</i>			<i>\$40.66</i>
EXXONMOBIL - ALL DEPARTMENTS			\$667.69

FACEBK DXVEYEF3A2

FACEBK DXVEYEF3A2	Hogadon - Operations	FB AD Job Fair	\$6.39
<i>FACEBK DXVEYEF3A2 - Total For Hogadon - Operations</i>			<i>\$6.39</i>
FACEBK DXVEYEF3A2 - ALL DEPARTMENTS			\$6.39

FACEBK GMCKFB3A2

FACEBK GMCKFB3A2	Hogadon - Operations	FB Ad Job Fair	\$39.42
<i>FACEBK GMCKFB3A2 - Total For Hogadon - Operations</i>			<i>\$39.42</i>
FACEBK GMCKFB3A2 - ALL DEPARTMENTS			\$39.42

FASTENAL COMPANY

FASTENAL COMPANY	Fire-EMS Operations	Equipment/Supplies for new engines	\$128.02
FASTENAL COMPANY	Fire-EMS Operations	Equipment/Supplies for new engines	\$62.79
<i>FASTENAL COMPANY - Total For Fire-EMS Operations</i>			<i>\$190.81</i>

FASTENAL COMPANY - ALL DEPARTMENTS

\$190.81

FBI NATIONAL ACADEMY

FBI NATIONAL ACADEMY	Police Career Services	SCHOOLS AND EDUCATIONAL SERVICES NOT	\$100.00
FBI NATIONAL ACADEMY	Police Career Services	SCHOOLS AND EDUCATIONAL SERVICES NOT	\$100.00
FBI NATIONAL ACADEMY	Police Career Services	SCHOOLS AND EDUCATIONAL SERVICES NOT	\$100.00
FBI NATIONAL ACADEMY	Police Career Services	SCHOOLS AND EDUCATIONAL SERVICES NOT	\$100.00

FBI NATIONAL ACADEMY - Total For Police Career Services \$400.00

FBI NATIONAL ACADEMY - ALL DEPARTMENTS

\$400.00

FEDEX 277645903837

FEDEX 277645903837	Fire-EMS Administration	Shipping bunker gear in for repair	\$15.62
--------------------	-------------------------	------------------------------------	---------

FEDEX 277645903837 - Total For Fire-EMS Administration \$15.62

FEDEX 277645903837 - ALL DEPARTMENTS

\$15.62

FEDEX 277862368869

FEDEX 277862368869	Fire-EMS Training	Shipping of SCBA bottles to NFPA 1700 Class	\$156.82
--------------------	-------------------	---	----------

FEDEX 277862368869 - Total For Fire-EMS Training \$156.82

FEDEX 277862368869 - ALL DEPARTMENTS

\$156.82

FERGUSON ENTERPRISES

FERGUSON ENTERPRISES	Water Distribution	Tool Retaining Screw for Tap Machine - Wate	\$98.32
----------------------	--------------------	---	---------

FERGUSON ENTERPRISES - Total For Water Distribution \$98.32

FERGUSON ENTERPRISES	WWTP Operations	Megaflange	\$532.65
----------------------	-----------------	------------	----------

FERGUSON ENTERPRISES - Total For WWTP Operations \$532.65

FERGUSON ENTERPRISES - ALL DEPARTMENTS

\$630.97

FIREPENNY

FIREPENNY	Fire-EMS Operations	Class A Foam	\$1,869.45
-----------	---------------------	--------------	------------

FIREPENNY - Total For Fire-EMS Operations \$1,869.45

FIREPENNY - ALL DEPARTMENTS

\$1,869.45

FIRST INTERSTATE BAN

FIRST INTERSTATE BAN	Balefill - Disposal & Landfill	Investment Fees - 8/16/22 to 9/15/22	\$931.93
<i>FIRST INTERSTATE BAN - Total For Balefill - Disposal & Landfill</i>			\$931.93
FIRST INTERSTATE BAN	Capital Projects Fund	Investment Fees - 8/16/22 to 9/15/22	\$3,335.88
<i>FIRST INTERSTATE BAN - Total For Capital Projects Fund</i>			\$3,335.88
FIRST INTERSTATE BAN	CARES Act Funding	Investment Fees - 8/16/22 to 9/15/22	\$919.69
<i>FIRST INTERSTATE BAN - Total For CARES Act Funding</i>			\$919.69
FIRST INTERSTATE BAN	General Fund Revenue	Investment Fees - 8/16/22 to 9/15/22	\$2,477.86
<i>FIRST INTERSTATE BAN - Total For General Fund Revenue</i>			\$2,477.86
FIRST INTERSTATE BAN	Health Insurance Fund	Investment Fees - 8/16/22 to 9/15/22	\$250.09
<i>FIRST INTERSTATE BAN - Total For Health Insurance Fund</i>			\$250.09
FIRST INTERSTATE BAN	Human Resources	Gift cards	\$175.00
<i>FIRST INTERSTATE BAN - Total For Human Resources</i>			\$175.00
FIRST INTERSTATE BAN	Local Assessment District Fun	Investment Fees - 8/16/22 to 9/15/22	\$35.45
<i>FIRST INTERSTATE BAN - Total For Local Assessment District Fund</i>			\$35.45
FIRST INTERSTATE BAN	Metro Animal Shelter	Investment Fees - 8/16/22 to 9/15/22	\$40.45
<i>FIRST INTERSTATE BAN - Total For Metro Animal Shelter</i>			\$40.45
FIRST INTERSTATE BAN	Opportunities Fund	Investment Fees - 8/16/22 to 9/15/22	\$479.81
<i>FIRST INTERSTATE BAN - Total For Opportunities Fund</i>			\$479.81
FIRST INTERSTATE BAN	Parking Fund	Investment Fees - 8/16/22 to 9/15/22	\$11.60
<i>FIRST INTERSTATE BAN - Total For Parking Fund</i>			\$11.60
FIRST INTERSTATE BAN	Perpetual Care Operations	Investment Fees - 8/16/22 to 9/15/22	\$2,166.22
<i>FIRST INTERSTATE BAN - Total For Perpetual Care Operations</i>			\$2,166.22
FIRST INTERSTATE BAN	Refuse - Residential	Investment Fees - 8/16/22 to 9/15/22	\$236.38
<i>FIRST INTERSTATE BAN - Total For Refuse - Residential</i>			\$236.38
FIRST INTERSTATE BAN	Revolving Land Fund	Investment Fees - 8/16/22 to 9/15/22	\$52.85
<i>FIRST INTERSTATE BAN - Total For Revolving Land Fund</i>			\$52.85
FIRST INTERSTATE BAN	River Fund	Investment Fees - 8/16/22 to 9/15/22	\$7.49
<i>FIRST INTERSTATE BAN - Total For River Fund</i>			\$7.49
FIRST INTERSTATE BAN	Sewer Administration	Investment Fees - 8/16/22 to 9/15/22	\$477.02
<i>FIRST INTERSTATE BAN - Total For Sewer Administration</i>			\$477.02
FIRST INTERSTATE BAN	Water Administration	Investment Fees - 8/16/22 to 9/15/22	\$1,370.42
<i>FIRST INTERSTATE BAN - Total For Water Administration</i>			\$1,370.42
FIRST INTERSTATE BAN	Weed & Pest Fund	Investment Fees - 8/16/22 to 9/15/22	\$58.65
<i>FIRST INTERSTATE BAN - Total For Weed & Pest Fund</i>			\$58.65

FIRST INTERSTATE BAN	WWTP Operations	Investment Fees - 8/16/22 to 9/15/22	\$880.43
<i>FIRST INTERSTATE BAN - Total For WWTP Operations</i>			<i>\$880.43</i>
FIRST INTERSTATE BAN - ALL DEPARTMENTS			\$13,907.22

FIRST VETERINARY SUP

FIRST VETERINARY SUP	Metro Animal Shelter	Veterinary supplies	\$500.25
FIRST VETERINARY SUP	Metro Animal Shelter	Veterinary supplies	\$363.58
FIRST VETERINARY SUP	Metro Animal Shelter	Veterinary supplies	\$178.31
<i>FIRST VETERINARY SUP - Total For Metro Animal Shelter</i>			<i>\$1,042.14</i>
FIRST VETERINARY SUP - ALL DEPARTMENTS			\$1,042.14

FISHER SCIENTIFIC

FISHER SCIENTIFIC	WWTP Operations	PHENOLPHTHALEIN	\$29.79
FISHER SCIENTIFIC	WWTP Operations	Lab supplies	\$47.12
<i>FISHER SCIENTIFIC - Total For WWTP Operations</i>			<i>\$76.91</i>
FISHER SCIENTIFIC - ALL DEPARTMENTS			\$76.91

FORT WORTH HILTON

FORT WORTH HILTON	Fire-EMS Training	Meal while attending NFPA 1700 Class	\$27.33
<i>FORT WORTH HILTON - Total For Fire-EMS Training</i>			<i>\$27.33</i>
FORT WORTH HILTON - ALL DEPARTMENTS			\$27.33

FOXSTER OPCO, LLC

FOXSTER OPCO, LLC	Public Transit - CARES Act	Trip Master Base, license, scheduler, etc	\$1,110.00
<i>FOXSTER OPCO, LLC - Total For Public Transit - CARES Act</i>			<i>\$1,110.00</i>
FOXSTER OPCO, LLC - ALL DEPARTMENTS			\$1,110.00

FSP CGFOA

FSP CGFOA	Finance	CGFOA annual conference - 11/15 to 11/18 -	\$350.00
<i>FSP CGFOA - Total For Finance</i>			<i>\$350.00</i>
FSP CGFOA - ALL DEPARTMENTS			\$350.00

GALLS, INC.

GALLS, INC.	Police Career Services	Uniform supplies	\$207.00
GALLS, INC.	Police Career Services	Uniform supplies	\$111.10
<i>GALLS, INC. - Total For Police Career Services</i>			<i>\$318.10</i>
GALLS, INC. - ALL DEPARTMENTS			\$318.10

GAMETIME

GAMETIME	Parks - Parks Maint.	Bracket & Powerlock Replacement	\$147.22
<i>GAMETIME - Total For Parks - Parks Maint.</i>			<i>\$147.22</i>
GAMETIME - ALL DEPARTMENTS			\$147.22

GEORGE T SANDERS

GEORGE T SANDERS	Water Distribution	1/2"X60" iron nipple 660270 vehicle supplies	\$32.58
<i>GEORGE T SANDERS - Total For Water Distribution</i>			<i>\$32.58</i>
GEORGE T SANDERS - ALL DEPARTMENTS			\$32.58

GEOSYNTEC CONSULTANT

GEOSYNTEC CONSULTANT	Balefill - Disposal & Landfill	Gems S028998-CRL Monitoring &	\$9,084.01
<i>GEOSYNTEC CONSULTANT - Total For Balefill - Disposal & Landfill</i>			<i>\$9,084.01</i>
GEOSYNTEC CONSULTANT - ALL DEPARTMENTS			\$9,084.01

GFOA

GFOA	Finance	GFOA Budget Book Submission Fee	\$575.00
<i>GFOA - Total For Finance</i>			<i>\$575.00</i>
GFOA - ALL DEPARTMENTS			\$575.00

GLOBAL EQUIPMENT COM

GLOBAL EQUIPMENT COM	Balefill - Disposal & Landfill	Mats for scale house	\$1,999.98
<i>GLOBAL EQUIPMENT COM - Total For Balefill - Disposal & Landfill</i>			<i>\$1,999.98</i>
GLOBAL EQUIPMENT COM - ALL DEPARTMENTS			\$1,999.98

GOLDER ASSOCIATES

GOLDER ASSOCIATES	Balefill - Disposal & Landfill	Gems S028759-5-Year Air Emissi	\$248.00
<i>GOLDER ASSOCIATES - Total For Balefill - Disposal & Landfill</i>			<i>\$248.00</i>
GOLDER ASSOCIATES - ALL DEPARTMENTS			\$248.00

GOLF & SPORT SOLUTIO

GOLF & SPORT SOLUTIO	Golf - Operations	Sand, delivery & fuel surcharge	\$1,938.86
<i>GOLF & SPORT SOLUTIO - Total For Golf - Operations</i>			<i>\$1,938.86</i>
GOLF & SPORT SOLUTIO - ALL DEPARTMENTS			\$1,938.86

GOLF AND SPORT SOLUT

GOLF AND SPORT SOLUT	Golf - Operations	30.73 tons of USGA sand	\$1,956.68
<i>GOLF AND SPORT SOLUT - Total For Golf - Operations</i>			<i>\$1,956.68</i>
GOLF AND SPORT SOLUT - ALL DEPARTMENTS			\$1,956.68

GOLF SAFETY

GOLF SAFETY	Weed & Pest Fund	Equipment Video Training	\$95.00
<i>GOLF SAFETY - Total For Weed & Pest Fund</i>			<i>\$95.00</i>
GOLF SAFETY - ALL DEPARTMENTS			\$95.00

GoToCom GoToMeeting

GoToCom GoToMeeting	Police Administration	CONTINUITY/SUBSCRIPTION MERCHANTS	\$768.00
<i>GoToCom GoToMeeting - Total For Police Administration</i>			<i>\$768.00</i>
GoToCom GoToMeeting - ALL DEPARTMENTS			\$768.00

GRAINGER, INC.

GRAINGER, INC.	Balefill - Diversion & Special	Gloves & safety vests	\$1,310.20
<i>GRAINGER, INC. - Total For Balefill - Diversion & Special</i>			<i>\$1,310.20</i>
GRAINGER, INC.	Buildings & Structures Fund	HVAC Repair supplies for Casper Business Ce	\$164.21
<i>GRAINGER, INC. - Total For Buildings & Structures Fund</i>			<i>\$164.21</i>
GRAINGER, INC.	Fire-EMS Operations	Fire hose adapter	\$518.13

<i>GRAINGER, INC. - Total For Fire-EMS Operations</i>			<i>\$518.13</i>
GRAINGER, INC.	Fire-EMS Prevent & Inspect	Sales tax credit on Fire Hose Adapter	(\$23.98)
<i>GRAINGER, INC. - Total For Fire-EMS Prevent & Inspect</i>			<i>(\$23.98)</i>
GRAINGER, INC.	Fleet Maintenance Fund	Printer label, desk top label printer	\$77.74
<i>GRAINGER, INC. - Total For Fleet Maintenance Fund</i>			<i>\$77.74</i>
GRAINGER, INC.	Regional Water Operations	HVAC filters	\$619.25
GRAINGER, INC.	Regional Water Operations	115V Motor	\$479.74
GRAINGER, INC.	Regional Water Operations	Measuring pipette	\$49.79
GRAINGER, INC.	Regional Water Operations	Ejector pump	\$1,400.85
<i>GRAINGER, INC. - Total For Regional Water Operations</i>			<i>\$2,549.63</i>
GRAINGER, INC.	Risk Management	Repair supplies for Aquatics Center due to po	\$179.10
<i>GRAINGER, INC. - Total For Risk Management</i>			<i>\$179.10</i>
GRAINGER, INC.	Sewer Wastewater Collection	UPS FOR SUNFLOWER RLS	\$388.66
<i>GRAINGER, INC. - Total For Sewer Wastewater Collection</i>			<i>\$388.66</i>
GRAINGER, INC.	WWTP Operations	Bulbs	\$39.20
GRAINGER, INC.	WWTP Operations	Spill containment	\$1,386.22
GRAINGER, INC.	WWTP Operations	Containment	\$274.58
<i>GRAINGER, INC. - Total For WWTP Operations</i>			<i>\$1,700.00</i>
GRAINGER, INC. - ALL DEPARTMENTS			\$6,863.69

GRANITE PEAK PUMP

GRANITE PEAK PUMP	Capital Projects Fund	Installation/Startup/Training of Pump Syste	\$6,720.00
<i>GRANITE PEAK PUMP - Total For Capital Projects Fund</i>			<i>\$6,720.00</i>
GRANITE PEAK PUMP - ALL DEPARTMENTS			\$6,720.00

GREINER MOTOR CO - C

GREINER MOTOR CO - C	Fleet Maintenance Fund	Vehicle repair	\$230.19
GREINER MOTOR CO - C	Fleet Maintenance Fund	Vehicle repair	\$117.44
<i>GREINER MOTOR CO - C - Total For Fleet Maintenance Fund</i>			<i>\$347.63</i>
GREINER MOTOR CO - C	Refuse - Residential	Pick-up (Supervisor) 2021 ford crew cab	\$60,778.00
<i>GREINER MOTOR CO - C - Total For Refuse - Residential</i>			<i>\$60,778.00</i>
GREINER MOTOR CO - C - ALL DEPARTMENTS			\$61,125.63

GUNNERS METERS

GUNNERS METERS	Water Meters	2" Cast Iron Flange - Meter Repair Parts	\$168.00
<i>GUNNERS METERS - Total For Water Meters</i>			<i>\$168.00</i>
GUNNERS METERS - ALL DEPARTMENTS			\$168.00

GUS GLOBALSTAR USA

GUS GLOBALSTAR USA	Public Safety Communication	TELECOMMUNICATION SERV.INCLUD. LOCAL	\$218.81
<i>GUS GLOBALSTAR USA - Total For Public Safety Communications</i>			<i>\$218.81</i>
GUS GLOBALSTAR USA - ALL DEPARTMENTS			\$218.81

H O BOSTROM CO

H O BOSTROM CO	Fire-EMS Operations	Seat cables for E22	\$282.24
<i>H O BOSTROM CO - Total For Fire-EMS Operations</i>			<i>\$282.24</i>
H O BOSTROM CO - ALL DEPARTMENTS			\$282.24

HACH CO., CORP.

HACH CO., CORP.	Regional Water Operations	Chlorine, DPD Compound, Ammonia, Surfact	\$198.58
HACH CO., CORP.	Regional Water Operations	Ammonia/Monochloramine	\$142.68
HACH CO., CORP.	Regional Water Operations	Chlorine	\$110.22
HACH CO., CORP.	Regional Water Operations	Ozone Accuvac & Formazin Turb STD	\$452.61
<i>HACH CO., CORP. - Total For Regional Water Operations</i>			<i>\$904.09</i>
HACH CO., CORP. - ALL DEPARTMENTS			\$904.09

HARBOR FREIGHT TOOLS

HARBOR FREIGHT TOOLS	Water Distribution	Tools for 660260, 660266, 660242 - Vehicle	\$86.95
HARBOR FREIGHT TOOLS	Water Distribution	150LB PULL RETRIEVING MAGNET VEHICLE S	\$9.99
<i>HARBOR FREIGHT TOOLS - Total For Water Distribution</i>			<i>\$96.94</i>
HARBOR FREIGHT TOOLS - ALL DEPARTMENTS			\$96.94

HARDWARE PARTNERS LL

HARDWARE PARTNERS LL	Buildings & Structures Fund	Lighting repair supplies for Metro Animal She	\$9.99
----------------------	-----------------------------	---	--------

<i>HARDWARE PARTNERS LL - Total For Buildings & Structures Fund</i>			\$9.99
HARDWARE PARTNERS LL	Fire-EMS Operations	Items for Rescue 1 Cribbing rebuild	\$46.95
<i>HARDWARE PARTNERS LL - Total For Fire-EMS Operations</i>			\$46.95
HARDWARE PARTNERS LL	Regional Water Operations	Electrical Parts for Stock & Shop Supplies - S	\$41.29
<i>HARDWARE PARTNERS LL - Total For Regional Water Operations</i>			\$41.29
HARDWARE PARTNERS LL - ALL DEPARTMENTS			\$98.23

HAT SIX TRAVEL CENTE

HAT SIX TRAVEL CENTE	Police Administration	AUTOMATED FUEL DISPENSERS	\$29.51
<i>HAT SIX TRAVEL CENTE - Total For Police Administration</i>			\$29.51
HAT SIX TRAVEL CENTE - ALL DEPARTMENTS			\$29.51

HAWKINS, INC.

HAWKINS, INC.	Aquatics - Operations	Chlorine Shock	\$655.00
HAWKINS, INC.	Aquatics - Operations	Chlorine, Acid	\$1,868.86
<i>HAWKINS, INC. - Total For Aquatics - Operations</i>			\$2,523.86
HAWKINS, INC. - ALL DEPARTMENTS			\$2,523.86

HDR ENGINEERING, INC

HDR ENGINEERING, INC	Water Administration	Water Rights Analysis & Studie	\$7,261.17
<i>HDR ENGINEERING, INC - Total For Water Administration</i>			\$7,261.17
HDR ENGINEERING, INC - ALL DEPARTMENTS			\$7,261.17

HERCULES INDUSTRIES

HERCULES INDUSTRIES	Buildings & Structures Fund	HVAC Repair supplies for Metro Animal Shelt	\$9.46
<i>HERCULES INDUSTRIES - Total For Buildings & Structures Fund</i>			\$9.46
HERCULES INDUSTRIES - ALL DEPARTMENTS			\$9.46

HILLTOP LAUNDROMAT

HILLTOP LAUNDROMAT	Public Transit - CARES Act	DRY CLEANERS -shop rags and mop heads	\$32.00
<i>HILLTOP LAUNDROMAT - Total For Public Transit - CARES Act</i>			\$32.00

HILLTOP LAUNDROMAT - ALL DEPARTMENTS \$32.00

HILTON HOTELS

HILTON HOTELS Fire-EMS Training Hotel Stay for Tye Herrorn for RERT2 Meetin \$259.90

HILTON HOTELS - Total For Fire-EMS Training \$259.90

HILTON HOTELS - ALL DEPARTMENTS \$259.90

HOMAX OIL SALES, INC

HOMAX OIL SALES, INC Balefill - Disposal & Landfill TEN (10) DIESEL FUEL SHIPMENTS \$34,965.37

HOMAX OIL SALES, INC - Total For Balefill - Disposal & Landfill \$34,965.37

HOMAX OIL SALES, INC Fleet Maintenance Fund Diesel fuel \$35,742.55

HOMAX OIL SALES, INC Fleet Maintenance Fund Unleaded fuel \$27,232.21

HOMAX OIL SALES, INC Fleet Maintenance Fund Blue DEF \$1,505.00

HOMAX OIL SALES, INC - Total For Fleet Maintenance Fund \$64,479.76

HOMAX OIL SALES, INC Water Distribution Fuel \$5,575.56

HOMAX OIL SALES, INC - Total For Water Distribution \$5,575.56

HOMAX OIL SALES, INC - ALL DEPARTMENTS \$105,020.69

HOOD'S EQUIPMENT & S

HOOD'S EQUIPMENT & S Fire-EMS Operations Snowblower for St. 6 \$874.47

HOOD'S EQUIPMENT & S - Total For Fire-EMS Operations \$874.47

HOOD'S EQUIPMENT & S WWTP Operations Weedeater parts \$53.42

HOOD'S EQUIPMENT & S - Total For WWTP Operations \$53.42

HOOD'S EQUIPMENT & S - ALL DEPARTMENTS \$927.89

HORIZON CABLE SERVIC

HORIZON CABLE SERVIC Refuse - Commercial Wire rope, choker & drop forge \$479.75

HORIZON CABLE SERVIC - Total For Refuse - Commercial \$479.75

HORIZON CABLE SERVIC - ALL DEPARTMENTS \$479.75

HOSE & RUBBER SUPPLY

HOSE & RUBBER SUPPLY Balefill - Disposal & Landfill Hydraulic hoses & supplies \$167.50

HOSE & RUBBER SUPPLY - Total For Balefill - Disposal & Landfill \$167.50

HOSE & RUBBER SUPPLY - ALL DEPARTMENTS \$167.50

HOSE AND RUBBER SUPP

HOSE AND RUBBER SUPP Fire-EMS Operations Equipment for new engines \$214.10

HOSE AND RUBBER SUPP - Total For Fire-EMS Operations \$214.10

HOSE AND RUBBER SUPP Sewer Wastewater Collection hose for 660317 \$291.46

HOSE AND RUBBER SUPP Sewer Wastewater Collection hose for 660316 \$66.00

HOSE AND RUBBER SUPP - Total For Sewer Wastewater Collection \$357.46

HOSE AND RUBBER SUPP Water Distribution 1" C5D High Temp Multi Hose - 660270 Truck \$45.89

HOSE AND RUBBER SUPP - Total For Water Distribution \$45.89

HOSE AND RUBBER SUPP WWTP Operations Belts \$18.50

HOSE AND RUBBER SUPP - Total For WWTP Operations \$18.50

HOSE AND RUBBER SUPP - ALL DEPARTMENTS \$635.95

HOTEL COLORADO

HOTEL COLORADO Police Career Services LODGING, HOTELS, MOTELS, RESORTS \$203.90

HOTEL COLORADO Police Career Services LODGING, HOTELS, MOTELS, RESORTS (\$11.90)

HOTEL COLORADO Police Career Services LODGING, HOTELS, MOTELS, RESORTS \$203.90

HOTEL COLORADO - Total For Police Career Services \$395.90

HOTEL COLORADO - ALL DEPARTMENTS \$395.90

HOWARD SUPPLY COMPAN

HOWARD SUPPLY COMPAN Balefill - Disposal & Landfill Flag magnet & slings \$539.36

HOWARD SUPPLY COMPAN Balefill - Disposal & Landfill ICE MAKER FOR EQUIP BLDG \$233.48

HOWARD SUPPLY COMPAN - Total For Balefill - Disposal & Landfill \$772.84

HOWARD SUPPLY COMPAN - ALL DEPARTMENTS \$772.84

ID CARD GROUP

ID CARD GROUP Hogadon - Operations Pass wickets \$119.22

ID CARD GROUP - Total For Hogadon - Operations \$119.22

ID CARD GROUP - ALL DEPARTMENTS \$119.22

INBERG-MILLER ENGINE

INBERG-MILLER ENGINE	Capital Projects Fund	Trail Condition Assessment	\$1,102.50
<i>INBERG-MILLER ENGINE - Total For Capital Projects Fund</i>			<i>\$1,102.50</i>
INBERG-MILLER ENGINE	Water Distribution	Testing of street construction & compaction	\$369.90
<i>INBERG-MILLER ENGINE - Total For Water Distribution</i>			<i>\$369.90</i>
INBERG-MILLER ENGINE - ALL DEPARTMENTS			\$1,472.40

INDUSTRIAL SCREEN &

INDUSTRIAL SCREEN &	Capital Projects Fund	Plates for new soccer well field control box	\$184.85
<i>INDUSTRIAL SCREEN & - Total For Capital Projects Fund</i>			<i>\$184.85</i>
INDUSTRIAL SCREEN & - ALL DEPARTMENTS			\$184.85

INGRAM BOOK COMPANY

INGRAM BOOK COMPANY	General Fund Revenue	Books for resale in museum store	\$184.80
<i>INGRAM BOOK COMPANY - Total For General Fund Revenue</i>			<i>\$184.80</i>
INGRAM BOOK COMPANY - ALL DEPARTMENTS			\$184.80

INSTALLATION & SVC.

INSTALLATION & SVC.	Water Distribution	Service & labor to dig up water leak	\$350.00
<i>INSTALLATION & SVC. - Total For Water Distribution</i>			<i>\$350.00</i>
INSTALLATION & SVC. - ALL DEPARTMENTS			\$350.00

INTERMOUNTAIN MOTOR

INTERMOUNTAIN MOTOR	WWTP Operations	Recondition blower #1 motor	\$1,950.00
INTERMOUNTAIN MOTOR	WWTP Operations	Balance motor	\$1,873.80
INTERMOUNTAIN MOTOR	WWTP Operations	Blower #1 motor	\$1,050.00
<i>INTERMOUNTAIN MOTOR - Total For WWTP Operations</i>			<i>\$4,873.80</i>
INTERMOUNTAIN MOTOR - ALL DEPARTMENTS			\$4,873.80

INTERSTATE ALL BATTE

INTERSTATE ALL BATTE	Sewer Wastewater Collection spotlight		\$14.35
----------------------	---------------------------------------	--	---------

INTERSTATE ALL BATTE - Total For Sewer Wastewater Collection \$14.35

INTERSTATE ALL BATTE - ALL DEPARTMENTS \$14.35

INT'L CODE COUNCIL I

INT'L CODE COUNCIL I Community Development Brian Training \$866.00

INT'L CODE COUNCIL I - Total For Community Development \$866.00

INT'L CODE COUNCIL I Fire-EMS Prevent & Inspect Test taking fee for ICC Fire Inspector 2 exam \$241.00

INT'L CODE COUNCIL I Fire-EMS Prevent & Inspect Certificaiton Renewals for Fire Inspector \$132.00

INT'L CODE COUNCIL I - Total For Fire-EMS Prevent & Inspect \$373.00

INT'L CODE COUNCIL I - ALL DEPARTMENTS \$1,239.00

INTUIT, INC.

INTUIT, INC. Capital Projects Fund Troubleshooting existing pumps before pum \$525.00

INTUIT, INC. - Total For Capital Projects Fund \$525.00

INTUIT, INC. Fire-EMS Administration PS Trax Station Automation-PPE Tracking Mo \$2,500.00

INTUIT, INC. - Total For Fire-EMS Administration \$2,500.00

INTUIT, INC. Fire-EMS Operations Wyoming Low Voltage - Station 3 wiring for \$145.00

INTUIT, INC. - Total For Fire-EMS Operations \$145.00

INTUIT, INC. Hogadon - Operations Lift tower repair \$5.34

INTUIT, INC. - Total For Hogadon - Operations \$5.34

INTUIT, INC. Public Safety Communication HEATING, PLUMBING, AIR CONDITIONING C \$342.98

INTUIT, INC. - Total For Public Safety Communications \$342.98

INTUIT, INC. Water Meters Bolts, Nuts, Washers for Large Meters - Mete \$112.44

INTUIT, INC. - Total For Water Meters \$112.44

INTUIT, INC. - ALL DEPARTMENTS \$3,630.76

ISA

ISA Parks - Urban Forestry ISA Membership for Mark Brattis \$187.00

ISA - Total For Parks - Urban Forestry \$187.00

ISA - ALL DEPARTMENTS \$187.00

JACK'S TRUCK & EQUIP

JACK'S TRUCK & EQUIP Fleet Maintenance Fund Equipment repair \$2,573.70

JACK'S TRUCK & EQUIP - Total For Fleet Maintenance Fund \$2,573.70

JACK'S TRUCK & EQUIP - ALL DEPARTMENTS \$2,573.70

JAKES GREENVILLE

JAKES GREENVILLE Fire-EMS Training Meal while attending NFPA 1700 Class \$14.92

JAKES GREENVILLE - Total For Fire-EMS Training \$14.92

JAKES GREENVILLE - ALL DEPARTMENTS \$14.92

JC GOLF ACCESSORIES

JC GOLF ACCESSORIES Golf Merchandise and Inventory \$381.37

JC GOLF ACCESSORIES - Total For Golf \$381.37

JC GOLF ACCESSORIES - ALL DEPARTMENTS \$381.37

JIMMY JOHNS -

JIMMY JOHNS - Parks - Parks Maint. NRPA Washington Park Discussion Lunch \$23.88

JIMMY JOHNS - Parks - Parks Maint. NRPA Washington Park Discussion Lunch \$88.34

JIMMY JOHNS - - Total For Parks - Parks Maint. \$112.22

JIMMY JOHNS - - ALL DEPARTMENTS \$112.22

JOHN R SHERMAN LLC

JOHN R SHERMAN LLC Revolving Land Fund Appraisal Report \$2,800.00

JOHN R SHERMAN LLC - Total For Revolving Land Fund \$2,800.00

JOHN R SHERMAN LLC - ALL DEPARTMENTS \$2,800.00

KNIFE RIVER/JTL

KNIFE RIVER/JTL Sewer Stormwater outfall repair \$340.03

KNIFE RIVER/JTL - Total For Sewer Stormwater \$340.03

KNIFE RIVER/JTL Streets 1/2" Plant Mix \$603.75

KNIFE RIVER/JTL Streets 1/2" Plant Mix \$466.50

KNIFE RIVER/JTL Streets 1/2" Plant Mix \$449.25

KNIFE RIVER/JTL Streets 1/2" Plant Mix \$608.25

KNIFE RIVER/JTL Streets City of Casper Mix, Fiber Mesh, Fuel Surcharg \$511.80

KNIFE RIVER/JTL	Streets	1/2" Plant Mix	\$761.25
KNIFE RIVER/JTL	Streets	1/2" Plant Mix	\$909.00
KNIFE RIVER/JTL	Streets	Crushed base	\$206.85
KNIFE RIVER/JTL	Streets	City of Casper Mix 1, Fiber Mesh, Fuel Surcha	\$270.91
<i>KNIFE RIVER/JTL - Total For Streets</i>			<i>\$4,787.56</i>
KNIFE RIVER/JTL - ALL DEPARTMENTS			\$5,127.59

KUBWATER RESOURCES,

KUBWATER RESOURCES,	WWTP Operations	Zetag polymer for dewatering	\$8,300.00
<i>KUBWATER RESOURCES, - Total For WWTP Operations</i>			<i>\$8,300.00</i>
KUBWATER RESOURCES, - ALL DEPARTMENTS			\$8,300.00

LAWSON PRODUCTS INC

LAWSON PRODUCTS INC	Fleet Maintenance Fund	Monthly rental	\$525.00
LAWSON PRODUCTS INC	Fleet Maintenance Fund	Monthly rental	\$375.00
<i>LAWSON PRODUCTS INC - Total For Fleet Maintenance Fund</i>			<i>\$900.00</i>
LAWSON PRODUCTS INC - ALL DEPARTMENTS			\$900.00

LES SCHWAB TIRES

LES SCHWAB TIRES	Fire-EMS Training	Tire repair while in Colorado for the Fire Mar	\$352.78
<i>LES SCHWAB TIRES - Total For Fire-EMS Training</i>			<i>\$352.78</i>
LES SCHWAB TIRES - ALL DEPARTMENTS			\$352.78

LISA'S SPIC N SPAN

LISA'S SPIC N SPAN	Balefill - Disposal & Landfill	Janitorial / cleaning service	\$260.00
<i>LISA'S SPIC N SPAN - Total For Balefill - Disposal & Landfill</i>			<i>\$260.00</i>
LISA'S SPIC N SPAN - ALL DEPARTMENTS			\$260.00

LITTLE CAESARS

LITTLE CAESARS	Police Investigations	FAST FOOD RESTAURANTS	\$22.02
<i>LITTLE CAESARS - Total For Police Investigations</i>			<i>\$22.02</i>

LITTLE CAESARS - ALL DEPARTMENTS \$22.02

LOAF N JUG #0115

LOAF N JUG #0115 Police Administration AUTOMATED FUEL DISPENSERS \$40.01

LOAF N JUG #0115 - Total For Police Administration \$40.01

LOAF N JUG #0115 - ALL DEPARTMENTS \$40.01

LOAF N JUG #0869

LOAF N JUG #0869 Police Career Services AUTOMATED FUEL DISPENSERS \$55.04

LOAF N JUG #0869 - Total For Police Career Services \$55.04

LOAF N JUG #0869 - ALL DEPARTMENTS \$55.04

LOVE'S #220

LOVE'S #220 Police Investigations SERVICE STATIONS \$55.52

LOVE'S #220 - Total For Police Investigations \$55.52

LOVE'S #220 - ALL DEPARTMENTS \$55.52

LOWER & CO PC

LOWER & CO PC Buildings & Structures Fund Structural engineering services \$1,300.00

LOWER & CO PC - Total For Buildings & Structures Fund \$1,300.00

LOWER & CO PC Golf - Operations Structural engineering services \$1,300.00

LOWER & CO PC - Total For Golf - Operations \$1,300.00

LOWER & CO PC Parking Fund Structural Engineering Services \$600.00

LOWER & CO PC - Total For Parking Fund \$600.00

LOWER & CO PC - ALL DEPARTMENTS \$3,200.00

MAGNET FORENSICS USA

MAGNET FORENSICS USA Police Administration PROFESSIONAL SERVICES NOT ELSEWHERE C \$4,600.00

MAGNET FORENSICS USA - Total For Police Administration \$4,600.00

MAGNET FORENSICS USA - ALL DEPARTMENTS \$4,600.00

MAVERIK #293

MAVERIK #293	Police Investigations	SERVICE STATIONS	\$35.38
<i>MAVERIK #293 - Total For Police Investigations</i>			<i>\$35.38</i>
MAVERIK #293 - ALL DEPARTMENTS			\$35.38

MD FURNITURE

MD FURNITURE	Rec Center - Operations	CRC Weight Vinyl Repair	\$525.00
<i>MD FURNITURE - Total For Rec Center - Operations</i>			<i>\$525.00</i>
MD FURNITURE - ALL DEPARTMENTS			\$525.00

MELGAARD CONSTRUCTIO

MELGAARD CONSTRUCTIO	Balefill - Disposal & Landfill	Cell 5 Construction (Earthwork	\$400,456.21
<i>MELGAARD CONSTRUCTIO - Total For Balefill - Disposal & Landfill</i>			<i>\$400,456.21</i>
MELGAARD CONSTRUCTIO - ALL DEPARTMENTS			\$400,456.21

MENARDS CASPER WY

MENARDS CASPER WY	Fire-EMS Operations	Bunker dryer supplies	\$101.97
MENARDS CASPER WY	Fire-EMS Operations	Clamps for new engines	\$8.42
MENARDS CASPER WY	Fire-EMS Operations	Station 1 Utility Sink	\$148.99
MENARDS CASPER WY	Fire-EMS Operations	Supplies for new engines	\$130.51
<i>MENARDS CASPER WY - Total For Fire-EMS Operations</i>			<i>\$389.89</i>
MENARDS CASPER WY	Parks - Parks Maint.	VS lights PRR Supplies Parks Supplies	\$5.49
<i>MENARDS CASPER WY - Total For Parks - Parks Maint.</i>			<i>\$5.49</i>
MENARDS CASPER WY	Police State Grants	VS lights PRR Supplies Parks Supplies	\$223.72
<i>MENARDS CASPER WY - Total For Police State Grants</i>			<i>\$223.72</i>
MENARDS CASPER WY	River Volunteer Events	VS lights PRR Supplies Parks Supplies	\$301.72
<i>MENARDS CASPER WY - Total For River Volunteer Events</i>			<i>\$301.72</i>
MENARDS CASPER WY - ALL DEPARTMENTS			\$920.82

MERCER HOUSE, INC.

MERCER HOUSE, INC.	Capital Projects Fund	1%#16 Funding Mercer Family Re	\$8,001.32
<i>MERCER HOUSE, INC. - Total For Capital Projects Fund</i>			<i>\$8,001.32</i>

MERCER HOUSE, INC. - ALL DEPARTMENTS

\$8,001.32

MIDLAND SCIENTIFIC

MIDLAND SCIENTIFIC	WWTP Operations	Lab supplies	\$150.20
--------------------	-----------------	--------------	----------

<i>MIDLAND SCIENTIFIC - Total For WWTP Operations</i>			\$150.20
---	--	--	----------

MIDLAND SCIENTIFIC - ALL DEPARTMENTS

\$150.20

ML AUTOMOTIVE

ML AUTOMOTIVE	Fleet Maintenance Fund	Vehicle alignment	\$221.78
---------------	------------------------	-------------------	----------

ML AUTOMOTIVE	Fleet Maintenance Fund	Vehicle alignment	\$157.00
---------------	------------------------	-------------------	----------

ML AUTOMOTIVE	Fleet Maintenance Fund	Vehicle alignment	\$87.00
---------------	------------------------	-------------------	---------

ML AUTOMOTIVE	Fleet Maintenance Fund	Vehicle alignment	\$157.00
---------------	------------------------	-------------------	----------

ML AUTOMOTIVE	Fleet Maintenance Fund	Vehicle alignment	\$157.00
---------------	------------------------	-------------------	----------

<i>ML AUTOMOTIVE - Total For Fleet Maintenance Fund</i>			\$779.78
---	--	--	----------

ML AUTOMOTIVE - ALL DEPARTMENTS

\$779.78

MODERN ELECTRIC CORP

MODERN ELECTRIC CORP	RWS - Booster Stations	Single phased motor repair	\$860.00
----------------------	------------------------	----------------------------	----------

<i>MODERN ELECTRIC CORP - Total For RWS - Booster Stations</i>			\$860.00
--	--	--	----------

MODERN ELECTRIC CORP - ALL DEPARTMENTS

\$860.00

Monson

Monson	Buildings & Structures Fund	Janitorial service	\$5,141.35
--------	-----------------------------	--------------------	------------

Monson	Buildings & Structures Fund	Janitorial service	\$225.00
--------	-----------------------------	--------------------	----------

<i>Monson - Total For Buildings & Structures Fund</i>			\$5,366.35
---	--	--	------------

Monson - ALL DEPARTMENTS

\$5,366.35

MOTION INDUSTRIES

MOTION INDUSTRIES	Balefill - Baler Processing	O RINGS FOR VENTS BALER BUILDING	\$270.01
-------------------	-----------------------------	----------------------------------	----------

<i>MOTION INDUSTRIES - Total For Balefill - Baler Processing</i>			\$270.01
--	--	--	----------

MOTION INDUSTRIES	WWTP Operations	Cone assemblies	\$1,907.20
-------------------	-----------------	-----------------	------------

MOTION INDUSTRIES	WWTP Operations	Bearings	\$1,252.93
-------------------	-----------------	----------	------------

MOTION INDUSTRIES	WWTP Operations	Bearings	\$2,406.98
MOTION INDUSTRIES	WWTP Operations	Credit	(\$2,406.98)
MOTION INDUSTRIES	WWTP Operations	Bearing assemblies	\$1,154.05
MOTION INDUSTRIES	WWTP Operations	Bearing assemblies	\$1,907.04
MOTION INDUSTRIES	WWTP Operations	Assemblies	\$1,907.06
MOTION INDUSTRIES	WWTP Operations	Bearings	\$1,907.11
<i>MOTION INDUSTRIES - Total For WWTP Operations</i>			\$10,035.39
MOTION INDUSTRIES - ALL DEPARTMENTS			\$10,305.40

MOTOROLA SOLUTIONS

MOTOROLA SOLUTIONS	Public Safety Communication Network Monitoring/Plus Pkg/Srvcs 11/1 to		\$9,457.67
<i>MOTOROLA SOLUTIONS - Total For Public Safety Communications</i>			\$9,457.67
MOTOROLA SOLUTIONS - ALL DEPARTMENTS			\$9,457.67

MOUNTAIN STATES

MOUNTAIN STATES	Police Administration	Printing service - business cards	\$415.43
<i>MOUNTAIN STATES - Total For Police Administration</i>			\$415.43
MOUNTAIN STATES - ALL DEPARTMENTS			\$415.43

MOUNTAIN STATES PIPE

MOUNTAIN STATES PIPE	Water Meters	Kamstrup Ultrasonic Water Meters/ Washers	\$1,996.00
<i>MOUNTAIN STATES PIPE - Total For Water Meters</i>			\$1,996.00
MOUNTAIN STATES PIPE - ALL DEPARTMENTS			\$1,996.00

MOUNTAIN WEST TECHNO

MOUNTAIN WEST TECHNO	Aquatics- Marion Kreiner Ope Acct #12214		\$10.00
<i>MOUNTAIN WEST TECHNO - Total For Aquatics- Marion Kreiner Oper.</i>			\$10.00
MOUNTAIN WEST TECHNO	Aquatics- Mike Sedar Oper. Acct #12213		\$10.00
<i>MOUNTAIN WEST TECHNO - Total For Aquatics- Mike Sedar Oper.</i>			\$10.00
MOUNTAIN WEST TECHNO	Aquatics- Paradise Valley Ope Acct #12212		\$5.00
<i>MOUNTAIN WEST TECHNO - Total For Aquatics- Paradise Valley Oper</i>			\$5.00
MOUNTAIN WEST TECHNO	Aquatics- Washington Oper Acct #12211		\$10.00
<i>MOUNTAIN WEST TECHNO - Total For Aquatics- Washington Oper</i>			\$10.00

MOUNTAIN WEST TECHNO	Buildings & Structures Fund	Acct #20778-20221003-2	\$78.37
MOUNTAIN WEST TECHNO	Buildings & Structures Fund	Acct #13502	\$49.95
<i>MOUNTAIN WEST TECHNO - Total For Buildings & Structures Fund</i>			<i>\$128.32</i>
MOUNTAIN WEST TECHNO	Capital Projects Fund	IRU contract for Fiber Usage f	\$506,809.00
<i>MOUNTAIN WEST TECHNO - Total For Capital Projects Fund</i>			<i>\$506,809.00</i>
MOUNTAIN WEST TECHNO - ALL DEPARTMENTS			\$506,972.32

MOUNTAIN WEST VALUAT

MOUNTAIN WEST VALUAT	Revolving Land Fund	Appraisal Report	\$1,500.00
MOUNTAIN WEST VALUAT	Revolving Land Fund	Appraisal Report	\$1,500.00
MOUNTAIN WEST VALUAT	Revolving Land Fund	Appraisal Report	\$3,000.00
<i>MOUNTAIN WEST VALUAT - Total For Revolving Land Fund</i>			<i>\$6,000.00</i>
MOUNTAIN WEST VALUAT - ALL DEPARTMENTS			\$6,000.00

MURDOCH'S RANCH&HOME

MURDOCH'S RANCH&HOM	Cemetery	weed eater string	\$89.97
<i>MURDOCH'S RANCH&HOME - Total For Cemetery</i>			<i>\$89.97</i>
MURDOCH'S RANCH&HOME - ALL DEPARTMENTS			\$89.97

NAPA AUTO PARTS CORP

NAPA AUTO PARTS CORP	Refuse - Residential	Booster cable	\$132.11
<i>NAPA AUTO PARTS CORP - Total For Refuse - Residential</i>			<i>\$132.11</i>
NAPA AUTO PARTS CORP	Regional Water Operations	Parts for Roof Vents - Machinery Supplies	\$23.18
NAPA AUTO PARTS CORP	Regional Water Operations	Belts for Roof Vent Motors - Machinery Supp	\$124.09
<i>NAPA AUTO PARTS CORP - Total For Regional Water Operations</i>			<i>\$147.27</i>
NAPA AUTO PARTS CORP - ALL DEPARTMENTS			\$279.38

NATRONA COUNTY OFFIC

NATRONA COUNTY OFFIC	Police Administration	Prisoner Housing - May 2022	\$105,631.11
NATRONA COUNTY OFFIC	Police Administration	Juvenile Detention - August 2022	\$7,500.00
NATRONA COUNTY OFFIC	Police Administration	Prisoner Housing - August 2022	\$133,265.38
NATRONA COUNTY OFFIC	Police Administration	Juvenile Detention - July 2022	\$7,500.00
<i>NATRONA COUNTY OFFIC - Total For Police Administration</i>			<i>\$253,896.49</i>

NATRONA COUNTY OFFIC - ALL DEPARTMENTS

\$253,896.49

NFPA NATL FIRE PROTE

NFPA NATL FIRE PROTE	Fire-EMS Prevent & Inspect	Pub-Ed plastic bags	\$329.45
----------------------	----------------------------	---------------------	----------

<i>NFPA NATL FIRE PROTE - Total For Fire-EMS Prevent & Inspect</i>			\$329.45
--	--	--	----------

NFPA NATL FIRE PROTE - ALL DEPARTMENTS

\$329.45

NORCO, INC.

NORCO, INC.	Buildings & Structures Fund	Bathroom tissue	\$304.96
-------------	-----------------------------	-----------------	----------

NORCO, INC.	Buildings & Structures Fund	Return of air freshener	(\$33.95)
-------------	-----------------------------	-------------------------	-----------

NORCO, INC.	Buildings & Structures Fund	Hand soap/garbage bags/bathroom tissue/cl	\$995.86
-------------	-----------------------------	---	----------

NORCO, INC.	Buildings & Structures Fund	Bathroom tissue/paper towels/latex gloves/c	\$178.10
-------------	-----------------------------	---	----------

<i>NORCO, INC. - Total For Buildings & Structures Fund</i>			\$1,444.97
--	--	--	------------

NORCO, INC.	Fleet Maintenance Fund	Cylinder rental	\$151.20
-------------	------------------------	-----------------	----------

<i>NORCO, INC. - Total For Fleet Maintenance Fund</i>			\$151.20
---	--	--	----------

NORCO, INC.	Refuse - Recycling	Garbage bags	\$625.20
-------------	--------------------	--------------	----------

<i>NORCO, INC. - Total For Refuse - Recycling</i>			\$625.20
---	--	--	----------

NORCO, INC.	Water Distribution	Welding Room supplies /Other materials & s	\$72.51
-------------	--------------------	--	---------

<i>NORCO, INC. - Total For Water Distribution</i>			\$72.51
---	--	--	---------

NORCO, INC. - ALL DEPARTMENTS

\$2,293.88

NORTHERN LIGHTS MANU

NORTHERN LIGHTS MANU	Refuse - Residential	Equipment repair & clean out	\$2,900.00
----------------------	----------------------	------------------------------	------------

<i>NORTHERN LIGHTS MANU - Total For Refuse - Residential</i>			\$2,900.00
--	--	--	------------

NORTHERN LIGHTS MANU - ALL DEPARTMENTS

\$2,900.00

NORTHFIELD COMMONS

NORTHFIELD COMMONS	Fire-EMS Training	Meal while attending Fire Marshal Conferenc	\$14.84
--------------------	-------------------	---	---------

<i>NORTHFIELD COMMONS - Total For Fire-EMS Training</i>			\$14.84
---	--	--	---------

NORTHFIELD COMMONS - ALL DEPARTMENTS

\$14.84

NORTHWEST CONTRACTOR

NORTHWEST CONTRACTOR	Balefill - Baler Processing	Bar Ames & Klein/chainsaw chain/sawzall bla	\$264.20
<i>NORTHWEST CONTRACTOR - Total For Balefill - Baler Processing</i>			<i>\$264.20</i>
NORTHWEST CONTRACTOR	Balefill - Disposal & Landfill	Railroad picks & handles	\$247.16
<i>NORTHWEST CONTRACTOR - Total For Balefill - Disposal & Landfill</i>			<i>\$247.16</i>
NORTHWEST CONTRACTOR	Fire-EMS Operations	Portable light and charger for each new engi	\$2,096.00
<i>NORTHWEST CONTRACTOR - Total For Fire-EMS Operations</i>			<i>\$2,096.00</i>
NORTHWEST CONTRACTOR	Refuse - Residential	Drill bit & kit/cylinder/torch/bungee cords/s	\$347.87
<i>NORTHWEST CONTRACTOR - Total For Refuse - Residential</i>			<i>\$347.87</i>
NORTHWEST CONTRACTOR	Sewer Wastewater Collection safety supplies		\$103.28
<i>NORTHWEST CONTRACTOR - Total For Sewer Wastewater Collection</i>			<i>\$103.28</i>
NORTHWEST CONTRACTOR	Streets	New paint gun for 761 & 931	\$101.38
<i>NORTHWEST CONTRACTOR - Total For Streets</i>			<i>\$101.38</i>
NORTHWEST CONTRACTOR	Traffic Control	Pin flags for locates	\$38.56
<i>NORTHWEST CONTRACTOR - Total For Traffic Control</i>			<i>\$38.56</i>
NORTHWEST CONTRACTOR	Water Distribution	Arbor Ring for 14" Concrete Saw - Other Mat	\$4.74
NORTHWEST CONTRACTOR	Water Distribution	14" Walk Behind Saw - Water & Sewerline M	\$99.00
<i>NORTHWEST CONTRACTOR - Total For Water Distribution</i>			<i>\$103.74</i>
NORTHWEST CONTRACTOR - ALL DEPARTMENTS			\$3,302.19

NVA CASPER VETERINAR

NVA CASPER VETERINAR	Police Administration	Veterinary services	\$203.54
<i>NVA CASPER VETERINAR - Total For Police Administration</i>			<i>\$203.54</i>
NVA CASPER VETERINAR - ALL DEPARTMENTS			\$203.54

OFFICE DEPOT

OFFICE DEPOT	Customer Service	1 magenta toner, 1 black toner	\$68.16
<i>OFFICE DEPOT - Total For Customer Service</i>			<i>\$68.16</i>
OFFICE DEPOT	Finance	1 magenta toner, 1 black toner	\$68.15
<i>OFFICE DEPOT - Total For Finance</i>			<i>\$68.15</i>
OFFICE DEPOT	Health Insurance Fund	1 magenta toner, 1 black toner	\$68.15
<i>OFFICE DEPOT - Total For Health Insurance Fund</i>			<i>\$68.15</i>
OFFICE DEPOT	Human Resources	1 magenta toner, 1 black toner	\$68.15
<i>OFFICE DEPOT - Total For Human Resources</i>			<i>\$68.15</i>
OFFICE DEPOT	Risk Management	1 magenta toner, 1 black toner	\$68.15

OFFICE DEPOT - Total For Risk Management \$68.15

OFFICE DEPOT - ALL DEPARTMENTS \$340.76

OMEGA INDUSTRIAL SU

OMEGA INDUSTRIAL SU Traffic Control 12 cans of spray graffiti remover \$259.94

OMEGA INDUSTRIAL SU - Total For Traffic Control \$259.94

OMEGA INDUSTRIAL SU - ALL DEPARTMENTS \$259.94

ONE CALL OF WY.

ONE CALL OF WY. Sewer Wastewater Collection Tickets for September 2022 \$373.61

ONE CALL OF WY. - Total For Sewer Wastewater Collection \$373.61

ONE CALL OF WY. Traffic Control Tickets for September 2022 \$102.00

ONE CALL OF WY. - Total For Traffic Control \$102.00

ONE CALL OF WY. Water Distribution Tickets for September 2022 \$456.64

ONE CALL OF WY. - Total For Water Distribution \$456.64

ONE CALL OF WY. - ALL DEPARTMENTS \$932.25

OPINION STAGE LTD

OPINION STAGE LTD City Manager Opinion Stage subscription \$99.00

OPINION STAGE LTD - Total For City Manager \$99.00

OPINION STAGE LTD - ALL DEPARTMENTS \$99.00

OREGON CALIFORNIA TR

OREGON CALIFORNIA TR Ft. Caspar Museum Double charge of membership, credit being i \$60.00

OREGON CALIFORNIA TR Ft. Caspar Museum Credit reimbursement from OCTA (\$60.00)

OREGON CALIFORNIA TR - Total For Ft. Caspar Museum \$0.00

OREGON CALIFORNIA TR - ALL DEPARTMENTS \$0.00

O'REILLY AUTO PARTS

O'REILLY AUTO PARTS Sewer Wastewater Collection backup camera mount repair \$15.99

O'REILLY AUTO PARTS - Total For Sewer Wastewater Collection \$15.99

O'REILLY AUTO PARTS - ALL DEPARTMENTS \$15.99

ORKIN LLC 002

ORKIN LLC 002 Hogadon - Operations Pest control \$150.97

ORKIN LLC 002 - Total For Hogadon - Operations \$150.97

ORKIN LLC 002 - ALL DEPARTMENTS \$150.97

PACIFIC STEEL BRANCH

PACIFIC STEEL BRANCH Water Distribution 3X4 1# X 20' CHANNEL SIDEBOARDS 660280 \$51.40

PACIFIC STEEL BRANCH - Total For Water Distribution \$51.40

PACIFIC STEEL BRANCH - ALL DEPARTMENTS \$51.40

PANDA EXPRESS

PANDA EXPRESS Police Administration FAST FOOD RESTAURANTS \$7.95

PANDA EXPRESS - Total For Police Administration \$7.95

PANDA EXPRESS - ALL DEPARTMENTS \$7.95

PAYPAL WYOCAMERA

PAYPAL WYOCAMERA Fire-EMS Training Emergency Scene Photography Class \$125.00

PAYPAL WYOCAMERA Fire-EMS Training Fees for Emergency Scene Photography class \$175.00

PAYPAL WYOCAMERA - Total For Fire-EMS Training \$300.00

PAYPAL WYOCAMERA - ALL DEPARTMENTS \$300.00

PEAK GEOSOLUTIONS/ S

PEAK GEOSOLUTIONS/ S Balefill - Disposal & Landfill PSC Peak CQA CRL Cell 5 Const \$44,255.75

PEAK GEOSOLUTIONS/ S - Total For Balefill - Disposal & Landfill \$44,255.75

PEAK GEOSOLUTIONS/ S - ALL DEPARTMENTS \$44,255.75

PETCO 1456

PETCO 1456 Metro Animal Control PET SHOPS-PET FOOD AND SUPPLY STORES \$115.96

PETCO 1456 - Total For Metro Animal Control \$115.96

PETCO 1456 - ALL DEPARTMENTS

\$115.96

PETSMART #3082

PETSMART #3082	Metro Animal Control	PET SHOPS-PET FOOD AND SUPPLY STORES	\$74.58
----------------	----------------------	--------------------------------------	---------

<i>PETSMART #3082 - Total For Metro Animal Control</i>			\$74.58
--	--	--	---------

PETSMART #3082	Metro Animal Shelter	PET SHOPS-PET FOOD AND SUPPLY STORES	\$76.91
----------------	----------------------	--------------------------------------	---------

PETSMART #3082	Metro Animal Shelter	PET SHOPS-PET FOOD AND SUPPLY STORES	\$49.92
----------------	----------------------	--------------------------------------	---------

PETSMART #3082	Metro Animal Shelter	PET SHOPS-PET FOOD AND SUPPLY STORES	\$74.95
----------------	----------------------	--------------------------------------	---------

PETSMART #3082	Metro Animal Shelter	PET SHOPS-PET FOOD AND SUPPLY STORES	\$11.99
----------------	----------------------	--------------------------------------	---------

<i>PETSMART #3082 - Total For Metro Animal Shelter</i>			\$213.77
--	--	--	----------

PETSMART #3082 - ALL DEPARTMENTS

\$288.35

PILOT

PILOT	Fire-EMS Training	Fuel for travel to the Fire Marshals Assoc. of	\$45.04
-------	-------------------	--	---------

<i>PILOT - Total For Fire-EMS Training</i>			\$45.04
--	--	--	---------

PILOT	Police Career Services	AUTOMATED FUEL DISPENSERS	\$28.83
-------	------------------------	---------------------------	---------

<i>PILOT - Total For Police Career Services</i>			\$28.83
---	--	--	---------

PILOT	Police Investigations	SERVICE STATIONS	\$23.79
-------	-----------------------	------------------	---------

<i>PILOT - Total For Police Investigations</i>			\$23.79
--	--	--	---------

PILOT - ALL DEPARTMENTS

\$97.66

PLAYITAGAINSP

PLAYITAGAINSP	Ice Arena - Concessions	ProShop Items for Resale	\$113.91
---------------	-------------------------	--------------------------	----------

<i>PLAYITAGAINSP - Total For Ice Arena - Concessions</i>			\$113.91
--	--	--	----------

PLAYITAGAINSP	Ice Arena - Operations	Professional CCM Skate Oven	\$450.00
---------------	------------------------	-----------------------------	----------

<i>PLAYITAGAINSP - Total For Ice Arena - Operations</i>			\$450.00
---	--	--	----------

PLAYITAGAINSP - ALL DEPARTMENTS

\$563.91

PORTER'S MOUNTAIN VI

PORTER'S MOUNTAIN VI	Fire-EMS Operations	Pellets for grillmaster	\$43.98
----------------------	---------------------	-------------------------	---------

<i>PORTER'S MOUNTAIN VI - Total For Fire-EMS Operations</i>			\$43.98
---	--	--	---------

PORTER'S MOUNTAIN VI - ALL DEPARTMENTS

\$43.98

POSTAL PROS, INC.

POSTAL PROS, INC.	Customer Service	UB/Past Due Notices-Printing/Postage/Maili	\$3,018.92
POSTAL PROS, INC.	Customer Service	UB/Past Due Notices-Printing/Postage/Maili	\$3,802.58
<i>POSTAL PROS, INC. - Total For Customer Service</i>			\$6,821.50
POSTAL PROS, INC. - ALL DEPARTMENTS			\$6,821.50

PP KUSTOMKONCE

PP KUSTOMKONCE	Fire-EMS Operations	Mounting plates for MDTs	\$436.80
<i>PP KUSTOMKONCE - Total For Fire-EMS Operations</i>			\$436.80
PP KUSTOMKONCE - ALL DEPARTMENTS			\$436.80

PP WYOMINGWATE

PP WYOMINGWATE	WWTP Operations	Training conference fees	\$750.00
<i>PP WYOMINGWATE - Total For WWTP Operations</i>			\$750.00
PP WYOMINGWATE - ALL DEPARTMENTS			\$750.00

PROFESSIONAL CLEANIN

PROFESSIONAL CLEANIN	WWTP Operations	Cleaning service - September 2022	\$1,395.00
<i>PROFESSIONAL CLEANIN - Total For WWTP Operations</i>			\$1,395.00
PROFESSIONAL CLEANIN - ALL DEPARTMENTS			\$1,395.00

RAMSHORN CONSTRUCTIO

RAMSHORN CONSTRUCTIO	Capital Projects Fund	2022 12th Street Improvements	\$117,206.25
<i>RAMSHORN CONSTRUCTIO - Total For Capital Projects Fund</i>			\$117,206.25
RAMSHORN CONSTRUCTIO	Water Distribution	2022 12th Street Improvements	\$20,900.00
<i>RAMSHORN CONSTRUCTIO - Total For Water Distribution</i>			\$20,900.00
RAMSHORN CONSTRUCTIO - ALL DEPARTMENTS			\$138,106.25

RAY ALLEN MANUFACTUR

RAY ALLEN MANUFACTUR	Police Administration	DURABLE GOODS,NOT ELSEWHERE CLASSIFI	(\$5.40)
<i>RAY ALLEN MANUFACTUR - Total For Police Administration</i>			(\$5.40)

RAY ALLEN MANUFACTUR - ALL DEPARTMENTS (\$5.40)

REEB WELDING LLC

REEB WELDING LLC Regional Water Operations Welding service \$792.00

REEB WELDING LLC - Total For Regional Water Operations \$792.00

REEB WELDING LLC - ALL DEPARTMENTS \$792.00

REVIVAL ANIMAL HEALT

REVIVAL ANIMAL HEALT Metro Animal Shelter PET SHOPS-PET FOOD AND SUPPLY STORES \$210.28

REVIVAL ANIMAL HEALT - Total For Metro Animal Shelter \$210.28

REVIVAL ANIMAL HEALT - ALL DEPARTMENTS \$210.28

REXEL USA INC

REXEL USA INC WWTP Operations Allen Bradley 1756-OF8 Controllogix \$3,600.11

REXEL USA INC - Total For WWTP Operations \$3,600.11

REXEL USA INC - ALL DEPARTMENTS \$3,600.11

RICOH USA INC

RICOH USA INC Metropolitan Planning Org Copier usage \$440.81

RICOH USA INC - Total For Metropolitan Planning Org \$440.81

RICOH USA INC - ALL DEPARTMENTS \$440.81

RMI CASPER

RMI CASPER WWTP Operations Calibration gas \$133.62

RMI CASPER - Total For WWTP Operations \$133.62

RMI CASPER - ALL DEPARTMENTS \$133.62

ROCKY MOUNTAIN POWER

ROCKY MOUNTAIN POWER Aquatics - Operations Acct #54730761-088 1 \$12,361.51

ROCKY MOUNTAIN POWER - Total For Aquatics - Operations \$12,361.51

ROCKY MOUNTAIN POWER Aquatics- Marion Kreiner Ope Acct #54730761-112 9 \$537.09

ROCKY MOUNTAIN POWER - Total For Aquatics- Marion Kreiner Oper.		\$537.09
ROCKY MOUNTAIN POWER	Aquatics- Mike Sedar Oper. Acct #54730761-112 9	\$3,045.18
ROCKY MOUNTAIN POWER - Total For Aquatics- Mike Sedar Oper.		\$3,045.18
ROCKY MOUNTAIN POWER	Aquatics- Paradise Valley Ope Acct #54730761-112 9	\$1,168.50
ROCKY MOUNTAIN POWER - Total For Aquatics- Paradise Valley Oper		\$1,168.50
ROCKY MOUNTAIN POWER	Aquatics- Washington Oper Acct #54730761-112 9	\$662.51
ROCKY MOUNTAIN POWER - Total For Aquatics- Washington Oper		\$662.51
ROCKY MOUNTAIN POWER	Balefill - Disposal & Landfill Thermal Lenses / CRL Electrical Srvc Upgrade	\$62,716.00
ROCKY MOUNTAIN POWER - Total For Balefill - Disposal & Landfill		\$62,716.00
ROCKY MOUNTAIN POWER	Cemetery Acct #54730761-092 3	\$106.46
ROCKY MOUNTAIN POWER - Total For Cemetery		\$106.46
ROCKY MOUNTAIN POWER	City Center Building Acct #54730761-093 1	\$1,205.50
ROCKY MOUNTAIN POWER - Total For City Center Building		\$1,205.50
ROCKY MOUNTAIN POWER	City Hall Acct #54730761-093 1	\$4,086.65
ROCKY MOUNTAIN POWER - Total For City Hall		\$4,086.65
ROCKY MOUNTAIN POWER	Ft. Caspar Museum Acct #54730761-098 0	\$736.06
ROCKY MOUNTAIN POWER - Total For Ft. Caspar Museum		\$736.06
ROCKY MOUNTAIN POWER	Golf - Operations Acct #54730761-099 8	\$4,905.38
ROCKY MOUNTAIN POWER - Total For Golf - Operations		\$4,905.38
ROCKY MOUNTAIN POWER	Hogadon - Operations Acct #54730761-126 9	\$2,243.39
ROCKY MOUNTAIN POWER - Total For Hogadon - Operations		\$2,243.39
ROCKY MOUNTAIN POWER	Ice Arena - Operations Acct #54730761-101 2	\$2,376.36
ROCKY MOUNTAIN POWER	Ice Arena - Operations Acct #54730761-147 5	\$4,528.77
ROCKY MOUNTAIN POWER - Total For Ice Arena - Operations		\$6,905.13
ROCKY MOUNTAIN POWER	Marathon Building Acct #54730761-093 1	\$414.92
ROCKY MOUNTAIN POWER - Total For Marathon Building		\$414.92
ROCKY MOUNTAIN POWER	Miller St. Dormitory Acct #54730761-093 1	\$34.79
ROCKY MOUNTAIN POWER - Total For Miller St. Dormitory		\$34.79
ROCKY MOUNTAIN POWER	Parks - Parks Maint. Acct #54730761-093 1	\$943.82
ROCKY MOUNTAIN POWER - Total For Parks - Parks Maint.		\$943.82
ROCKY MOUNTAIN POWER	Public Safety Communication Acct #54730761-146 7	\$318.63
ROCKY MOUNTAIN POWER - Total For Public Safety Communications		\$318.63
ROCKY MOUNTAIN POWER	Public Transit - CARES Act Acct #54730761-156 6	\$284.49
ROCKY MOUNTAIN POWER - Total For Public Transit - CARES Act		\$284.49
ROCKY MOUNTAIN POWER	RWS - Booster Stations Acct #60931133-001 1	\$25.02
ROCKY MOUNTAIN POWER	RWS - Booster Stations Acct #60931133-021 9	\$24.20

ROCKY MOUNTAIN POWER	RWS - Booster Stations	Acct #60931133-024 3	\$24.83
ROCKY MOUNTAIN POWER	RWS - Booster Stations	Acct #60931133-025 0	\$2,765.72
<i>ROCKY MOUNTAIN POWER - Total For RWS - Booster Stations</i>			<i>\$2,839.77</i>
ROCKY MOUNTAIN POWER	Sewer Wastewater Collection	Acct #54730761-105 3	\$397.46
<i>ROCKY MOUNTAIN POWER - Total For Sewer Wastewater Collection</i>			<i>\$397.46</i>
ROCKY MOUNTAIN POWER	Water Tanks	Acct #54730761-002 2	\$1,566.17
ROCKY MOUNTAIN POWER	Water Tanks	Acct #54730761-135 0	\$90.11
<i>ROCKY MOUNTAIN POWER - Total For Water Tanks</i>			<i>\$1,656.28</i>
ROCKY MOUNTAIN POWER - ALL DEPARTMENTS			\$107,569.52

ROCKY MTN. FIRE SYST

ROCKY MTN. FIRE SYST	Rec Center - Operations	HVAC Duct CRC	\$85.00
<i>ROCKY MTN. FIRE SYST - Total For Rec Center - Operations</i>			<i>\$85.00</i>
ROCKY MTN. FIRE SYST - ALL DEPARTMENTS			\$85.00

ROGUE

ROGUE	Fire-EMS Training	Fitness equipment - Pull-up Package	\$85.70
<i>ROGUE - Total For Fire-EMS Training</i>			<i>\$85.70</i>
ROGUE - ALL DEPARTMENTS			\$85.70

Rooter

Rooter	Buildings & Structures Fund	Pumping service on septic system	\$655.00
<i>Rooter - Total For Buildings & Structures Fund</i>			<i>\$655.00</i>
Rooter	Golf - Operations	Portable restroom rental	\$560.00
<i>Rooter - Total For Golf - Operations</i>			<i>\$560.00</i>
Rooter	Parks - Parks Maint.	Porta-John from R&R	\$331.65
Rooter	Parks - Parks Maint.	Porta-John from R&R	\$853.65
Rooter	Parks - Parks Maint.	Porta-John from R&R	\$104.40
Rooter	Parks - Parks Maint.	Porta-John from R&R	\$2.23
<i>Rooter - Total For Parks - Parks Maint.</i>			<i>\$1,291.93</i>
Rooter - ALL DEPARTMENTS			\$2,506.93

SAFARILAND LLC

SAFARILAND LLC	Police Career Services	SPORTING GOODS STORES	\$306.34
<i>SAFARILAND LLC - Total For Police Career Services</i>			<i>\$306.34</i>
SAFARILAND LLC - ALL DEPARTMENTS			\$306.34

SAFETY KLEEN SYSTEMS

SAFETY KLEEN SYSTEMS	Golf - Operations	Parts washer service and rental	\$608.63
<i>SAFETY KLEEN SYSTEMS - Total For Golf - Operations</i>			<i>\$608.63</i>
SAFETY KLEEN SYSTEMS - ALL DEPARTMENTS			\$608.63

SAMS CLUB #6425

SAMS CLUB #6425	Community Development	WHOLESALE CLUBS	\$40.64
<i>SAMS CLUB #6425 - Total For Community Development</i>			<i>\$40.64</i>
SAMS CLUB #6425	Fire-EMS Operations	Station Supplies	\$338.18
SAMS CLUB #6425	Fire-EMS Operations	Station Supplies	\$27.78
<i>SAMS CLUB #6425 - Total For Fire-EMS Operations</i>			<i>\$365.96</i>
SAMS CLUB #6425	Ice Arena - Concessions	Concessions Resale Items	\$253.16
<i>SAMS CLUB #6425 - Total For Ice Arena - Concessions</i>			<i>\$253.16</i>
SAMS CLUB #6425 - ALL DEPARTMENTS			\$659.76

SAMSCLUB #6425

SAMSCLUB #6425	Aquatics - Operations	Trash Bags	\$27.19
<i>SAMSCLUB #6425 - Total For Aquatics - Operations</i>			<i>\$27.19</i>
SAMSCLUB #6425	Balefill - Baler Processing	BALER SUPPLIES	\$191.82
<i>SAMSCLUB #6425 - Total For Balefill - Baler Processing</i>			<i>\$191.82</i>
SAMSCLUB #6425	Balefill - Disposal & Landfill	PAPER TOWELS	\$128.46
<i>SAMSCLUB #6425 - Total For Balefill - Disposal & Landfill</i>			<i>\$128.46</i>
SAMSCLUB #6425	Balefill - Diversion & Special	PAPER TOWELS	\$21.38
<i>SAMSCLUB #6425 - Total For Balefill - Diversion & Special</i>			<i>\$21.38</i>
SAMSCLUB #6425	Capital Projects Fund	WHOLESALE CLUBS	\$359.86
<i>SAMSCLUB #6425 - Total For Capital Projects Fund</i>			<i>\$359.86</i>
SAMSCLUB #6425	Fire-EMS Operations	Floor dry container for new engines	\$14.98
<i>SAMSCLUB #6425 - Total For Fire-EMS Operations</i>			<i>\$14.98</i>
SAMSCLUB #6425	Police Administration	WHOLESALE CLUBS	\$692.70

SAMSCLUB #6425	Police Administration	WHOLESALE CLUBS	\$92.86
<i>SAMSCLUB #6425 - Total For Police Administration</i>			\$785.56
SAMSCLUB #6425	Sewer Wastewater Collection	office supplies	\$59.94
<i>SAMSCLUB #6425 - Total For Sewer Wastewater Collection</i>			\$59.94
SAMSCLUB #6425	Water Distribution	Office/Building Supplies	\$292.68
<i>SAMSCLUB #6425 - Total For Water Distribution</i>			\$292.68
SAMSCLUB #6425 - ALL DEPARTMENTS			\$1,881.87

SCREEN CYCLE

SCREEN CYCLE	Balefill - Diversion & Special	SCREEN REPAIR ZONAR	\$149.99
<i>SCREEN CYCLE - Total For Balefill - Diversion & Special</i>			\$149.99
SCREEN CYCLE - ALL DEPARTMENTS			\$149.99

SEAWESTERN FIRE FIGH

SEAWESTERN FIRE FIGH	Risk Management	Replacement hose - Claim Number 2023031	\$593.02
<i>SEAWESTERN FIRE FIGH - Total For Risk Management</i>			\$593.02
SEAWESTERN FIRE FIGH - ALL DEPARTMENTS			\$593.02

SHEET METAL SPECIALT

SHEET METAL SPECIALT	Capital Projects Fund	Flashing for door at soccer pumphouse	\$125.20
<i>SHEET METAL SPECIALT - Total For Capital Projects Fund</i>			\$125.20
SHEET METAL SPECIALT - ALL DEPARTMENTS			\$125.20

SHELL OIL 5744430220

SHELL OIL 5744430220	Police Investigations	SERVICE STATIONS	\$35.96
<i>SHELL OIL 5744430220 - Total For Police Investigations</i>			\$35.96
SHELL OIL 5744430220 - ALL DEPARTMENTS			\$35.96

SHELL OIL 5744602990

SHELL OIL 5744602990	Police Career Services	AUTOMATED FUEL DISPENSERS	\$45.61
<i>SHELL OIL 5744602990 - Total For Police Career Services</i>			\$45.61

SHELL OIL 5744602990 - ALL DEPARTMENTS \$45.61

SHERWIN-WILLIAMS COR

SHERWIN-WILLIAMS COR	Balefill - Disposal & Landfill	Paint	\$638.48
<i>SHERWIN-WILLIAMS COR - Total For Balefill - Disposal & Landfill</i>			\$638.48
SHERWIN-WILLIAMS COR	Buildings & Structures Fund	Painting supplies for Rec Center - Sherwin Wi	\$133.71
SHERWIN-WILLIAMS COR	Buildings & Structures Fund	Painting supplies for Rec Center - Sherwin Wi	\$44.57
<i>SHERWIN-WILLIAMS COR - Total For Buildings & Structures Fund</i>			\$178.28
SHERWIN-WILLIAMS COR	Capital Projects Fund	Paint for flashing on door at soccer pumphou	\$142.55
SHERWIN-WILLIAMS COR	Capital Projects Fund	Primer for door flashing at the soccer pumph	\$11.78
<i>SHERWIN-WILLIAMS COR - Total For Capital Projects Fund</i>			\$154.33
SHERWIN-WILLIAMS COR	Ice Arena - Operations	Paint for Zamboni Room, Ice Arena	\$237.44
<i>SHERWIN-WILLIAMS COR - Total For Ice Arena - Operations</i>			\$237.44
SHERWIN-WILLIAMS COR - ALL DEPARTMENTS			\$1,208.53

SHIRTS & MORE INC

SHIRTS & MORE INC	Risk Management	Traffic signal box wrap	\$400.00
<i>SHIRTS & MORE INC - Total For Risk Management</i>			\$400.00
SHIRTS & MORE INC - ALL DEPARTMENTS			\$400.00

SIMPKINS-CANTERBURY

SIMPKINS-CANTERBURY	General Fund Revenue	Ornaments for resale in museum store	\$660.73
<i>SIMPKINS-CANTERBURY - Total For General Fund Revenue</i>			\$660.73
SIMPKINS-CANTERBURY - ALL DEPARTMENTS			\$660.73

SIMPLOT T&H DEN

SIMPLOT T&H DEN	Weed & Pest Fund	Fungicide	\$1,342.50
<i>SIMPLOT T&H DEN - Total For Weed & Pest Fund</i>			\$1,342.50
SIMPLOT T&H DEN - ALL DEPARTMENTS			\$1,342.50

SIMPLOT TURF & HORTI

SIMPLOT TURF & HORTI	Golf - Operations	Instrata Fungicide	\$1,342.50
----------------------	-------------------	--------------------	------------

<i>SIMPLOT TURF & HORTI - Total For Golf - Operations</i>			\$1,342.50
SIMPLOT TURF & HORTI - ALL DEPARTMENTS			\$1,342.50

SIRIUSWARE INC

SIRIUSWARE INC	Hogadon - Operations	Maintenance & technical support-09/2022 t	\$3,223.85
<i>SIRIUSWARE INC - Total For Hogadon - Operations</i>			<i>\$3,223.85</i>
SIRIUSWARE INC - ALL DEPARTMENTS			\$3,223.85

SKC WEST

SKC WEST	Fire-EMS Operations	Sorbent Tube, Tenax TA	\$188.19
<i>SKC WEST - Total For Fire-EMS Operations</i>			<i>\$188.19</i>
SKC WEST - ALL DEPARTMENTS			\$188.19

SKILLPATH / NATIONAL

SKILLPATH / NATIONAL	Balefill - Disposal & Landfill	TRAINING	\$179.00
<i>SKILLPATH / NATIONAL - Total For Balefill - Disposal & Landfill</i>			<i>\$179.00</i>
SKILLPATH / NATIONAL - ALL DEPARTMENTS			\$179.00

SKYLINE RANCHES

SKYLINE RANCHES	Sewer Fund	Retail Sewer Revenue/201 Sewer Billing/Ad	\$1,080.88
SKYLINE RANCHES	Sewer Fund	Retail Sewer Revenue/201 Sewer Billing/Ad	(\$108.09)
<i>SKYLINE RANCHES - Total For Sewer Fund</i>			<i>\$972.79</i>
SKYLINE RANCHES	WWTP Revenue and Transfer	Retail Sewer Revenue/201 Sewer Billing/Ad	(\$955.36)
<i>SKYLINE RANCHES - Total For WWTP Revenue and Transfers</i>			<i>(\$955.36)</i>
SKYLINE RANCHES - ALL DEPARTMENTS			\$17.43

SMASH BURGER B

SMASH BURGER B	Fire-EMS Training	Meal while attending the NFPA 1700 Class	\$16.10
<i>SMASH BURGER B - Total For Fire-EMS Training</i>			<i>\$16.10</i>
SMASH BURGER B - ALL DEPARTMENTS			\$16.10

SMITHS FOOD #4185

SMITHS FOOD #4185	Fire-EMS Administration	Office Supplies	\$7.98
-------------------	-------------------------	-----------------	--------

<i>SMITHS FOOD #4185 - Total For Fire-EMS Administration</i>			<i>\$7.98</i>
--	--	--	---------------

SMITHS FOOD #4185 - ALL DEPARTMENTS			\$7.98
--	--	--	---------------

SO PT HOTEL AND CASI

SO PT HOTEL AND CASI	Police Career Services	LODGING, HOTELS, MOTELS, RESORTS	\$66.67
----------------------	------------------------	----------------------------------	---------

SO PT HOTEL AND CASI	Police Career Services	LODGING, HOTELS, MOTELS, RESORTS	\$66.67
----------------------	------------------------	----------------------------------	---------

SO PT HOTEL AND CASI	Police Career Services	LODGING, HOTELS, MOTELS, RESORTS	\$66.67
----------------------	------------------------	----------------------------------	---------

SO PT HOTEL AND CASI	Police Career Services	LODGING, HOTELS, MOTELS, RESORTS	\$66.67
----------------------	------------------------	----------------------------------	---------

<i>SO PT HOTEL AND CASI - Total For Police Career Services</i>			<i>\$266.68</i>
--	--	--	-----------------

SO PT HOTEL AND CASI - ALL DEPARTMENTS			\$266.68
---	--	--	-----------------

SOLID WASTE ASSOCIA

SOLID WASTE ASSOCIA	Balefill - Disposal & Landfill	DUES SWANA	\$245.00
---------------------	--------------------------------	------------	----------

<i>SOLID WASTE ASSOCIA - Total For Balefill - Disposal & Landfill</i>			<i>\$245.00</i>
---	--	--	-----------------

SOLID WASTE ASSOCIA - ALL DEPARTMENTS			\$245.00
--	--	--	-----------------

SONNYS RV SALES

SONNYS RV SALES	Streets	Propane for patch truck and oil distributor in	\$194.33
-----------------	---------	--	----------

<i>SONNYS RV SALES - Total For Streets</i>			<i>\$194.33</i>
--	--	--	-----------------

SONNYS RV SALES - ALL DEPARTMENTS			\$194.33
--	--	--	-----------------

SOURCE OFFICE

SOURCE OFFICE	Public Safety Communication	STATIONERY,OFFICE SUPPLIES,PRINTING AN	\$195.35
---------------	-----------------------------	--	----------

<i>SOURCE OFFICE - Total For Public Safety Communications</i>			<i>\$195.35</i>
---	--	--	-----------------

SOURCE OFFICE - ALL DEPARTMENTS			\$195.35
--	--	--	-----------------

SP ADVEXURE.COM

SP ADVEXURE.COM	Risk Management	MISCELLANEOUS GENERAL MERCHANDISE S	\$620.00
-----------------	-----------------	-------------------------------------	----------

<i>SP ADVEXURE.COM - Total For Risk Management</i>			<i>\$620.00</i>
--	--	--	-----------------

SP ADVEXURE.COM - ALL DEPARTMENTS \$620.00

SPARE LABS INC

SPARE LABS INC Public Transit - CARES Act Metered Max Active Vehicles - 9/01/22 to 9/ \$2,895.83

SPARE LABS INC - Total For Public Transit - CARES Act \$2,895.83

SPARE LABS INC - ALL DEPARTMENTS \$2,895.83

SPF45

SPF45 Fire-EMS Training Fule while attending Fire Marshal's Conferen \$54.82

SPF45 - Total For Fire-EMS Training \$54.82

SPF45 - ALL DEPARTMENTS \$54.82

SQ BONANZA PUBLISHI

SQ BONANZA PUBLISHI General Fund Revenue Books for resale in gift shop \$452.62

SQ BONANZA PUBLISHI - Total For General Fund Revenue \$452.62

SQ BONANZA PUBLISHI - ALL DEPARTMENTS \$452.62

SQ BUFFALO BILL MEM

SQ BUFFALO BILL MEM Ft. Caspar Museum Shipping for paintings donation \$30.91

SQ BUFFALO BILL MEM - Total For Ft. Caspar Museum \$30.91

SQ BUFFALO BILL MEM - ALL DEPARTMENTS \$30.91

SQ CK MECHANICAL

SQ CK MECHANICAL Fire-EMS Operations Plumbing Evaluation Service Fee \$89.00

SQ CK MECHANICAL - Total For Fire-EMS Operations \$89.00

SQ CK MECHANICAL - ALL DEPARTMENTS \$89.00

SQ COMPUTER PROFESS

SQ COMPUTER PROFESS Balefill - Disposal & Landfill UPS BACK UP BATTERIES \$278.00

SQ COMPUTER PROFESS - Total For Balefill - Disposal & Landfill \$278.00

SQ COMPUTER PROFESS Community Development COMPUTER MAINTENANCE,REPAIR & SERVIC \$178.57

<i>SQ COMPUTER PROFESS - Total For Community Development</i>			<i>\$178.57</i>
SQ COMPUTER PROFESS	Customer Service	BATTERY REPLACEMENT	\$14.68
<i>SQ COMPUTER PROFESS - Total For Customer Service</i>			<i>\$14.68</i>
SQ COMPUTER PROFESS	Fire-EMS Administration	Diplay port to HDMI 3' cable/HDMI over Cat	\$151.10
<i>SQ COMPUTER PROFESS - Total For Fire-EMS Administration</i>			<i>\$151.10</i>
SQ COMPUTER PROFESS	Hogadon - Operations	Battery backup	\$139.00
<i>SQ COMPUTER PROFESS - Total For Hogadon - Operations</i>			<i>\$139.00</i>
SQ COMPUTER PROFESS	Police Administration	COMPUTER MAINTENANCE,REPAIR & SERVIC	\$93.85
<i>SQ COMPUTER PROFESS - Total For Police Administration</i>			<i>\$93.85</i>
SQ COMPUTER PROFESS	Risk Management	COMPUTER MAINTENANCE,REPAIR & SERVIC	\$142.86
<i>SQ COMPUTER PROFESS - Total For Risk Management</i>			<i>\$142.86</i>
SQ COMPUTER PROFESS - ALL DEPARTMENTS			\$998.06

SQ CROWN FORMALWEAR

SQ CROWN FORMALWEAR	Fire-EMS Administration	Class A Uniform Measurements	\$10.00
<i>SQ CROWN FORMALWEAR - Total For Fire-EMS Administration</i>			<i>\$10.00</i>
SQ CROWN FORMALWEAR - ALL DEPARTMENTS			\$10.00

SQ PEDEN'S INC.

SQ PEDEN'S INC.	Police Administration	MEN'S AND WOMEN'S CLOTHING STORES	\$25.00
<i>SQ PEDEN'S INC. - Total For Police Administration</i>			<i>\$25.00</i>
SQ PEDEN'S INC.	Police Career Services	MEN'S AND WOMEN'S CLOTHING STORES	\$316.00
<i>SQ PEDEN'S INC. - Total For Police Career Services</i>			<i>\$316.00</i>
SQ PEDEN'S INC. - ALL DEPARTMENTS			\$341.00

SQ SELF

SQ SELF	Police Investigations	PROFESSIONAL SERVICES NOT ELSEWHERE C	\$78.00
<i>SQ SELF - Total For Police Investigations</i>			<i>\$78.00</i>
SQ SELF - ALL DEPARTMENTS			\$78.00

SQ WYATT ELECTRIC I

SQ WYATT ELECTRIC I	Parks - Parks Maint.	Replace broken plastic pull box at skate park	\$418.30
SQ WYATT ELECTRIC I	Parks - Parks Maint.	Troubleshoot pump at Paradise Valley Park	\$83.13

SQ WYATT ELECTRIC I	Parks - Parks Maint.	Troubleshoot lighting problem at skate park	\$290.23
SQ WYATT ELECTRIC I	Parks - Parks Maint.	Repair broken conduits and refeed electrical	\$1,756.93
<i>SQ WYATT ELECTRIC I - Total For Parks - Parks Maint.</i>			<i>\$2,548.59</i>
SQ WYATT ELECTRIC I - ALL DEPARTMENTS			\$2,548.59

SQUARESPACE INC.

SQUARESPACE INC.	City Manager	Website subscription	\$33.00
<i>SQUARESPACE INC. - Total For City Manager</i>			<i>\$33.00</i>
SQUARESPACE INC. - ALL DEPARTMENTS			\$33.00

STAPLES

STAPLES	Aquatics - Operations	Office Chairs	\$399.98
<i>STAPLES - Total For Aquatics - Operations</i>			<i>\$399.98</i>
STAPLES	Balefill - Disposal & Landfill	JUMP DRIVES FOR MAINTENANCE BUILDING	\$25.98
<i>STAPLES - Total For Balefill - Disposal & Landfill</i>			<i>\$25.98</i>
STAPLES	Balefill - Diversion & Special	CREDIT FOR DESK THAT WAS NOT AVAILABLE	(\$833.99)
<i>STAPLES - Total For Balefill - Diversion & Special</i>			<i>(\$833.99)</i>
STAPLES	Fire-EMS Operations	Station Supplies	\$88.76
<i>STAPLES - Total For Fire-EMS Operations</i>			<i>\$88.76</i>
STAPLES	Water Distribution	USB Unifying Receiver Returned - Technolog	(\$15.99)
<i>STAPLES - Total For Water Distribution</i>			<i>(\$15.99)</i>
STAPLES - ALL DEPARTMENTS			(\$335.26)

STAPLES DIRECT

STAPLES DIRECT	Police Federal Grants	STATIONERY,OFFICE SUPPLIES,PRINTING AN	\$108.14
STAPLES DIRECT	Police Federal Grants	STATIONERY,OFFICE SUPPLIES,PRINTING AN	(\$5.15)
<i>STAPLES DIRECT - Total For Police Federal Grants</i>			<i>\$102.99</i>
STAPLES DIRECT - ALL DEPARTMENTS			\$102.99

STAPLETON STAYBRDIGE

STAPLETON STAYBRDIGE	Fire-EMS Training	Hotel Room For Chief Moore to attend the Fi	\$623.68
<i>STAPLETON STAYBRDIGE - Total For Fire-EMS Training</i>			<i>\$623.68</i>

STAPLETON STAYBRDIGE - ALL DEPARTMENTS

\$623.68

STARBUCKS 800-782-72

STARBUCKS 800-782-72	Police Administration	FAST FOOD RESTAURANTS	\$3.62
----------------------	-----------------------	-----------------------	--------

<i>STARBUCKS 800-782-72 - Total For Police Administration</i>			\$3.62
---	--	--	--------

STARBUCKS 800-782-72 - ALL DEPARTMENTS

\$3.62

STARBUCKS STORE

STARBUCKS STORE	Fire-EMS Training	Meal while traveling to take new recruits to	\$10.18
-----------------	-------------------	--	---------

<i>STARBUCKS STORE - Total For Fire-EMS Training</i>			\$10.18
--	--	--	---------

STARBUCKS STORE	Police Investigations	FAST FOOD RESTAURANTS	\$63.00
-----------------	-----------------------	-----------------------	---------

STARBUCKS STORE	Police Investigations	FAST FOOD RESTAURANTS	\$6.04
-----------------	-----------------------	-----------------------	--------

<i>STARBUCKS STORE - Total For Police Investigations</i>			\$69.04
--	--	--	---------

STARBUCKS STORE - ALL DEPARTMENTS

\$79.22

STATE OF NEBRASKA -

STATE OF NEBRASKA -	Police Administration	GOVERNMENT SERVICES NOT ELSEWHERE CL	\$7.50
---------------------	-----------------------	--------------------------------------	--------

<i>STATE OF NEBRASKA - - Total For Police Administration</i>			\$7.50
--	--	--	--------

STATE OF NEBRASKA - - ALL DEPARTMENTS

\$7.50

STATE OF WY.

STATE OF WY.	Health Insurance Fund	Retiree Subsidy - October 2022	\$3,871.67
--------------	-----------------------	--------------------------------	------------

<i>STATE OF WY. - Total For Health Insurance Fund</i>			\$3,871.67
---	--	--	------------

STATE OF WY.	WWTP Operations	Loan #CW128GR	\$3,434.22
--------------	-----------------	---------------	------------

<i>STATE OF WY. - Total For WWTP Operations</i>			\$3,434.22
---	--	--	------------

STATE OF WY. - ALL DEPARTMENTS

\$7,305.89

STERLING

STERLING	Human Resources	Centralized employee background	\$662.77
----------	-----------------	---------------------------------	----------

<i>STERLING - Total For Human Resources</i>			\$662.77
---	--	--	----------

STERLING - ALL DEPARTMENTS

\$662.77

SUMMIT FIRE & SECURI

SUMMIT FIRE & SECURI	Balefill - Disposal & Landfill	Fire extinguisher	\$85.00
<i>SUMMIT FIRE & SECURI - Total For Balefill - Disposal & Landfill</i>			<i>\$85.00</i>
SUMMIT FIRE & SECURI	Police Administration	Fire extinguisher recharge, testing & misc par	\$361.00
<i>SUMMIT FIRE & SECURI - Total For Police Administration</i>			<i>\$361.00</i>
SUMMIT FIRE & SECURI - ALL DEPARTMENTS			\$446.00

SUMMIT FIRE AND SECU

SUMMIT FIRE AND SECU	Fire-EMS Operations	Equipment/Supplies for new engines	\$573.00
SUMMIT FIRE AND SECU	Fire-EMS Operations	Equipment/Supplies for new engines	\$357.00
<i>SUMMIT FIRE AND SECU - Total For Fire-EMS Operations</i>			<i>\$930.00</i>
SUMMIT FIRE AND SECU - ALL DEPARTMENTS			\$930.00

SUTHERLANDS 2219

SUTHERLANDS 2219	Water Distribution	Black Spray Paint - Other Materials & Supplie	\$11.98
<i>SUTHERLANDS 2219 - Total For Water Distribution</i>			<i>\$11.98</i>
SUTHERLANDS 2219 - ALL DEPARTMENTS			\$11.98

SWI, LLC

SWI, LLC	Balefill - Disposal & Landfill	Solid Waste Entrance Gate	\$38,198.08
<i>SWI, LLC - Total For Balefill - Disposal & Landfill</i>			<i>\$38,198.08</i>
SWI, LLC - ALL DEPARTMENTS			\$38,198.08

TEXAS ROADHOUSE FR

TEXAS ROADHOUSE FR	Public Transit - CARES Act	EATING PLACES, RESTAURANTS	\$19.48
<i>TEXAS ROADHOUSE FR - Total For Public Transit - CARES Act</i>			<i>\$19.48</i>
TEXAS ROADHOUSE FR - ALL DEPARTMENTS			\$19.48

TGI FRIDAY'S

TGI FRIDAY'S	Fire-EMS Training	Meal while attending Fire Marshal Conferenc	\$29.48
<i>TGI FRIDAY'S - Total For Fire-EMS Training</i>			<i>\$29.48</i>

TGI FRIDAY'S - ALL DEPARTMENTS

\$29.48

THATCHER CO.

THATCHER CO.	WWTP Regional Interceptors	Ferrous chloride delivery on 10/3/22.	\$17,039.61
--------------	----------------------------	---------------------------------------	-------------

<i>THATCHER CO. - Total For WWTP Regional Interceptors</i>			\$17,039.61
--	--	--	-------------

THATCHER CO. - ALL DEPARTMENTS

\$17,039.61

THE ARC OF NATRONA C

THE ARC OF NATRONA C	Capital Projects Fund	1%#16 Funding The Arc of Natro	\$2,916.69
----------------------	-----------------------	--------------------------------	------------

THE ARC OF NATRONA C	Capital Projects Fund	1%#16 Funding The Arc of Natro	\$2,916.69
----------------------	-----------------------	--------------------------------	------------

THE ARC OF NATRONA C	Capital Projects Fund	1%#16 Funding The Arc of Natro	\$2,916.69
----------------------	-----------------------	--------------------------------	------------

<i>THE ARC OF NATRONA C - Total For Capital Projects Fund</i>			\$8,750.07
---	--	--	------------

THE ARC OF NATRONA C - ALL DEPARTMENTS

\$8,750.07

THE DOORMAN LLC

THE DOORMAN LLC	Golf - Operations	Fixed Garage Doors on Cart Barns	\$150.00
-----------------	-------------------	----------------------------------	----------

<i>THE DOORMAN LLC - Total For Golf - Operations</i>			\$150.00
--	--	--	----------

THE DOORMAN LLC - ALL DEPARTMENTS

\$150.00

THE GOODYEAR TIRE &

THE GOODYEAR TIRE &	Fleet Maintenance Fund	Tire repair, valve stems & fuel surcharge	\$318.35
---------------------	------------------------	---	----------

THE GOODYEAR TIRE &	Fleet Maintenance Fund	Tire valve stems, tire mount/dismount	\$1,941.83
---------------------	------------------------	---------------------------------------	------------

<i>THE GOODYEAR TIRE & - Total For Fleet Maintenance Fund</i>			\$2,260.18
---	--	--	------------

THE GOODYEAR TIRE & - ALL DEPARTMENTS

\$2,260.18

THE HOME DEPOT

THE HOME DEPOT	Balefill - Baler Processing	BOLTS AND MATT PLAZMA TABLE	\$73.24
----------------	-----------------------------	-----------------------------	---------

<i>THE HOME DEPOT - Total For Balefill - Baler Processing</i>			\$73.24
---	--	--	---------

THE HOME DEPOT	Capital Projects Fund	sakrete for wet well pour at soccer pump ho	\$165.34
----------------	-----------------------	---	----------

THE HOME DEPOT	Capital Projects Fund	Return of pallet for refund	(\$20.00)
----------------	-----------------------	-----------------------------	-----------

<i>THE HOME DEPOT - Total For Capital Projects Fund</i>			\$145.34
---	--	--	----------

THE HOME DEPOT	Fire-EMS Operations	Lumber for Rescue 1	\$44.40
----------------	---------------------	---------------------	---------

THE HOME DEPOT	Fire-EMS Operations	Refridgerator for the station	\$62.96
<i>THE HOME DEPOT - Total For Fire-EMS Operations</i>			<i>\$107.36</i>
THE HOME DEPOT	Parks - Athletic Maint.	Misc. Tool for Athletics	\$48.87
<i>THE HOME DEPOT - Total For Parks - Athletic Maint.</i>			<i>\$48.87</i>
THE HOME DEPOT	Refuse - Residential	COMB AND TRUCK BARN SUPPLIES	\$148.91
<i>THE HOME DEPOT - Total For Refuse - Residential</i>			<i>\$148.91</i>
THE HOME DEPOT	Water Meters	Zip Ties & Blue Paint Other Materials & Suppl	\$55.84
<i>THE HOME DEPOT - Total For Water Meters</i>			<i>\$55.84</i>
THE HOME DEPOT	Weed & Pest Fund	safety supplies	\$49.26
<i>THE HOME DEPOT - Total For Weed & Pest Fund</i>			<i>\$49.26</i>
THE HOME DEPOT - ALL DEPARTMENTS			\$628.82

THE WASH LLC

THE WASH LLC	Police Administration	Car wash	\$14.51
<i>THE WASH LLC - Total For Police Administration</i>			<i>\$14.51</i>
THE WASH LLC - ALL DEPARTMENTS			\$14.51

TITAN DISTRIBUTORS I

TITAN DISTRIBUTORS I	Fire-EMS Training	Workout equipment	\$194.20
<i>TITAN DISTRIBUTORS I - Total For Fire-EMS Training</i>			<i>\$194.20</i>
TITAN DISTRIBUTORS I - ALL DEPARTMENTS			\$194.20

TOP OFFICE PRODUCTS

TOP OFFICE PRODUCTS	City Attorney	Copy charge - September 2022	\$175.68
<i>TOP OFFICE PRODUCTS - Total For City Attorney</i>			<i>\$175.68</i>
TOP OFFICE PRODUCTS	Fleet Maintenance Fund	Copy charge - September 2022	\$51.40
<i>TOP OFFICE PRODUCTS - Total For Fleet Maintenance Fund</i>			<i>\$51.40</i>
TOP OFFICE PRODUCTS	Parks - Parks Maint.	Copy charge - September 2022	\$51.40
<i>TOP OFFICE PRODUCTS - Total For Parks - Parks Maint.</i>			<i>\$51.40</i>
TOP OFFICE PRODUCTS	Public Transit - Operations	Copy Charge -August 2022	\$174.84
<i>TOP OFFICE PRODUCTS - Total For Public Transit - Operations</i>			<i>\$174.84</i>
TOP OFFICE PRODUCTS	Streets	Copy charge - September 2022	\$51.40
<i>TOP OFFICE PRODUCTS - Total For Streets</i>			<i>\$51.40</i>

TOP OFFICE PRODUCTS	Water Distribution	Copy charge - September 2022	\$108.11
<i>TOP OFFICE PRODUCTS - Total For Water Distribution</i>			<i>\$108.11</i>
TOP OFFICE PRODUCTS	WWTP Operations	Copy charge - September 2022	\$112.10
<i>TOP OFFICE PRODUCTS - Total For WWTP Operations</i>			<i>\$112.10</i>
TOP OFFICE PRODUCTS - ALL DEPARTMENTS			\$724.93

TOWNEPLACE SUITES DE

TOWNEPLACE SUITES DE	Police Investigations	MARRIOT/TOWNPLACE SUITES	\$367.90
<i>TOWNEPLACE SUITES DE - Total For Police Investigations</i>			<i>\$367.90</i>
TOWNEPLACE SUITES DE - ALL DEPARTMENTS			\$367.90

TRACTOR SUPPLY CO

TRACTOR SUPPLY CO	Metro Animal Shelter	MISCELLANEOUS AUTOMOTIVE DEALERS	\$12.58
<i>TRACTOR SUPPLY CO - Total For Metro Animal Shelter</i>			<i>\$12.58</i>
TRACTOR SUPPLY CO	Water Distribution	Driver spring - Shop/ Bldg. Supplies	\$44.99
<i>TRACTOR SUPPLY CO - Total For Water Distribution</i>			<i>\$44.99</i>
TRACTOR SUPPLY CO - ALL DEPARTMENTS			\$57.57

TRANSUNION RISK AND

TRANSUNION RISK AND	Police Investigations	Acct #220805	\$195.00
<i>TRANSUNION RISK AND - Total For Police Investigations</i>			<i>\$195.00</i>
TRANSUNION RISK AND - ALL DEPARTMENTS			\$195.00

TRETO CONST.

TRETO CONST.	Capital Projects Fund	Contract Withholding: 22300189	\$11,605.00
TRETO CONST.	Capital Projects Fund	Industrial Avenue Elm-David Co	\$53,077.45
<i>TRETO CONST. - Total For Capital Projects Fund</i>			<i>\$64,682.45</i>
TRETO CONST. - ALL DEPARTMENTS			\$64,682.45

TST CITY BREW COFFE

TST CITY BREW COFFE	Police Investigations	EATING PLACES, RESTAURANTS	\$6.04
<i>TST CITY BREW COFFE - Total For Police Investigations</i>			<i>\$6.04</i>

TST CITY BREW COFFE - ALL DEPARTMENTS \$6.04

TST Eggingtons

TST Eggingtons City Council Breakfast meeting \$84.08

TST Eggingtons - Total For City Council \$84.08

TST Eggingtons - ALL DEPARTMENTS \$84.08

TST WYOMING RIB

TST WYOMING RIB City Council Lunch meeting \$67.50

TST WYOMING RIB - Total For City Council \$67.50

TST WYOMING RIB City Manager Lunch meeting \$67.49

TST WYOMING RIB - Total For City Manager \$67.49

TST WYOMING RIB - ALL DEPARTMENTS \$134.99

TW ENTERPRISES INC

TW ENTERPRISES INC Fleet Maintenance Fund Generator repair \$194.00

TW ENTERPRISES INC - Total For Fleet Maintenance Fund \$194.00

TW ENTERPRISES INC - ALL DEPARTMENTS \$194.00

UBER TRIP

UBER TRIP Police Career Services TAXICABS/LIMOUSINES \$18.98

UBER TRIP Police Career Services TAXICABS/LIMOUSINES \$5.00

UBER TRIP Police Career Services TAXICABS/LIMOUSINES \$5.00

UBER TRIP Police Career Services TAXICABS/LIMOUSINES \$16.91

UBER TRIP Police Career Services TAXICABS/LIMOUSINES \$5.00

UBER TRIP Police Career Services TAXICABS/LIMOUSINES \$16.93

UBER TRIP - Total For Police Career Services \$67.82

UBER TRIP - ALL DEPARTMENTS \$67.82

ULINE SHIP SUPPLIE

ULINE SHIP SUPPLIE Water Distribution Wide Span Storage Rack - Meter Rm/Invento \$303.00

ULINE SHIP SUPPLIE - Total For Water Distribution \$303.00

ULINE SHIP SUPPLIE - ALL DEPARTMENTS \$303.00

UNIFORMS 2 GEAR

UNIFORMS 2 GEAR	Police Career Services	Uniform supplies	\$211.06
UNIFORMS 2 GEAR	Police Career Services	Uniform supplies	\$48.00
UNIFORMS 2 GEAR	Police Career Services	Uniform supplies	\$309.04

UNIFORMS 2 GEAR - Total For Police Career Services \$568.10

UNIFORMS 2 GEAR - ALL DEPARTMENTS \$568.10

UNITED 0162432852

UNITED 0162432852	City Manager	Travel expense to ICMA conference	\$762.70
-------------------	--------------	-----------------------------------	----------

UNITED 0162432852 - Total For City Manager \$762.70

UNITED 0162432852 - ALL DEPARTMENTS \$762.70

UNITED 0162435454

UNITED 0162435454	Water Meters	UNITED AIRLINES Flight for 2022 Neptune Sc	\$1,006.20
UNITED 0162435454	Water Meters	United Airlines B576K9 P-Card Flight for 202	\$1,006.20

UNITED 0162435454 - Total For Water Meters \$2,012.40

UNITED 0162435454 - ALL DEPARTMENTS \$2,012.40

UNITED 0162435637

UNITED 0162435637	Police Career Services	UNITED AIRLINES	\$508.20
UNITED 0162435637	Police Career Services	UNITED AIRLINES	\$508.20
UNITED 0162435637	Police Career Services	UNITED AIRLINES	\$508.20
UNITED 0162435637	Police Career Services	UNITED AIRLINES	\$508.20

UNITED 0162435637 - Total For Police Career Services \$2,032.80

UNITED 0162435637 - ALL DEPARTMENTS \$2,032.80

UNITED 0164202140

UNITED 0164202140	Police Career Services	UNITED AIRLINES	\$35.00
-------------------	------------------------	-----------------	---------

UNITED 0164202140 - Total For Police Career Services \$35.00

UNITED 0164202140 - ALL DEPARTMENTS \$35.00

UNITED 0164202424

UNITED 0164202424 City Manager Travel expense to ICMA conference \$28.00

UNITED 0164202424 City Manager Travel expense to ICMA conference \$28.00

UNITED 0164202424 - Total For City Manager \$56.00

UNITED 0164202424 - ALL DEPARTMENTS \$56.00

UNITED 0164202844

UNITED 0164202844 Police Career Services UNITED AIRLINES \$35.00

UNITED 0164202844 - Total For Police Career Services \$35.00

UNITED 0164202844 - ALL DEPARTMENTS \$35.00

UNITED 0164205307

UNITED 0164205307 Fire-EMS Training Baggage fee for flight to NFPA 1700 class \$45.00

UNITED 0164205307 Fire-EMS Training Baggage fee for flight to NFPA 1700 Class \$35.00

UNITED 0164205307 - Total For Fire-EMS Training \$80.00

UNITED 0164205307 - ALL DEPARTMENTS \$80.00

UNITED 0164208923

UNITED 0164208923 Community Development Amber bag check for conference \$30.00

UNITED 0164208923 Community Development Amber bag check for conference \$30.00

UNITED 0164208923 - Total For Community Development \$60.00

UNITED 0164208923 - ALL DEPARTMENTS \$60.00

URGENT CARE OF CASPE

URGENT CARE OF CASPE Public Transit - CARES Act DOT Physicals \$505.00

URGENT CARE OF CASPE - Total For Public Transit - CARES Act \$505.00

URGENT CARE OF CASPE - ALL DEPARTMENTS \$505.00

USPS PO 5715580478

USPS PO 5715580478	Parks - Parks Maint.	POSTAGE STAMPS	\$12.00
<i>USPS PO 5715580478 - Total For Parks - Parks Maint.</i>			<i>\$12.00</i>
USPS PO 5715580478 - ALL DEPARTMENTS			\$12.00

VCN NATRONAREALESTAT

VCN NATRONAREALESTAT	Community Development	Recording	\$258.02
VCN NATRONAREALESTAT	Community Development	Recording	\$77.50
<i>VCN NATRONAREALESTAT - Total For Community Development</i>			<i>\$335.52</i>
VCN NATRONAREALESTAT - ALL DEPARTMENTS			\$335.52

VERIZON WIRELESS

VERIZON WIRELESS	Balefill - Disposal & Landfill	Acct #642199740-00001	\$289.72
VERIZON WIRELESS	Balefill - Disposal & Landfill	Acct #642199740-00001	\$344.48
<i>VERIZON WIRELESS - Total For Balefill - Disposal & Landfill</i>			<i>\$634.20</i>
VERIZON WIRELESS	Fire-EMS Administration	Acct #571507176-00001	\$1,600.40
VERIZON WIRELESS	Fire-EMS Administration	Acct #571507176-00002	\$120.03
<i>VERIZON WIRELESS - Total For Fire-EMS Administration</i>			<i>\$1,720.43</i>
VERIZON WIRELESS	Parks - Parks Maint.	Acct #342080735-00001	\$469.63
<i>VERIZON WIRELESS - Total For Parks - Parks Maint.</i>			<i>\$469.63</i>
VERIZON WIRELESS	Public Safety Communication	Acct #771153835-00001	\$279.70
<i>VERIZON WIRELESS - Total For Public Safety Communications</i>			<i>\$279.70</i>
VERIZON WIRELESS	Sewer Wastewater Collection	Acct #742239432-00002	\$74.79
<i>VERIZON WIRELESS - Total For Sewer Wastewater Collection</i>			<i>\$74.79</i>
VERIZON WIRELESS	Streets	Acct #242152162-00001	\$66.35
<i>VERIZON WIRELESS - Total For Streets</i>			<i>\$66.35</i>
VERIZON WIRELESS	Water Meters	Acct #942021615-00001	\$266.71
<i>VERIZON WIRELESS - Total For Water Meters</i>			<i>\$266.71</i>
VERIZON WIRELESS - ALL DEPARTMENTS			\$3,511.81

WAL-MART #1617

WAL-MART #1617	Fire-EMS Administration	Coffee and water for Fire Admin	\$38.40
<i>WAL-MART #1617 - Total For Fire-EMS Administration</i>			<i>\$38.40</i>
WAL-MART #1617	Fire-EMS Operations	Station Supplies	\$42.00

<i>WAL-MART #1617 - Total For Fire-EMS Operations</i>			<i>\$42.00</i>
WAL-MART #1617	Metro Animal Shelter	GROCERY STORES, SUPERMARKETS	\$109.52
<i>WAL-MART #1617 - Total For Metro Animal Shelter</i>			<i>\$109.52</i>
WAL-MART #1617	Police Administration	GROCERY STORES, SUPERMARKETS	\$21.46
<i>WAL-MART #1617 - Total For Police Administration</i>			<i>\$21.46</i>
WAL-MART #1617	Police Federal Grants	GROCERY STORES, SUPERMARKETS	\$104.88
<i>WAL-MART #1617 - Total For Police Federal Grants</i>			<i>\$104.88</i>
WAL-MART #1617 - ALL DEPARTMENTS			\$316.26

WAL-MART #3778

WAL-MART #3778	Community Development	GROCERY STORES, SUPERMARKETS	\$26.56
<i>WAL-MART #3778 - Total For Community Development</i>			<i>\$26.56</i>
WAL-MART #3778	Municipal Court	GROCERY STORES, SUPERMARKETS	\$42.17
<i>WAL-MART #3778 - Total For Municipal Court</i>			<i>\$42.17</i>
WAL-MART #3778 - ALL DEPARTMENTS			\$68.73

WAL-MART #4653

WAL-MART #4653	Fire-EMS Training	Fuel for travel to Cheyenne for RERT2 Meeti	\$90.52
<i>WAL-MART #4653 - Total For Fire-EMS Training</i>			<i>\$90.52</i>
WAL-MART #4653 - ALL DEPARTMENTS			\$90.52

WALMART.COM AA

WALMART.COM AA	Police Administration	DISCOUNT STORES	\$83.83
<i>WALMART.COM AA - Total For Police Administration</i>			<i>\$83.83</i>
WALMART.COM AA	Police Investigations	DISCOUNT STORES	\$358.91
<i>WALMART.COM AA - Total For Police Investigations</i>			<i>\$358.91</i>
WALMART.COM AA - ALL DEPARTMENTS			\$442.74

WARDWELL WATER & SEW

WARDWELL WATER & SEW	RWS - Booster Stations	Monthly water charge	\$157.39
<i>WARDWELL WATER & SEW - Total For RWS - Booster Stations</i>			<i>\$157.39</i>
WARDWELL WATER & SEW - ALL DEPARTMENTS			\$157.39

WAYNE COLEMAN CONSTR

WAYNE COLEMAN CONSTR	Capital Projects Fund	Contract Withholding: 21300076	\$2,000.00
<i>WAYNE COLEMAN CONSTR - Total For Capital Projects Fund</i>			<i>\$2,000.00</i>
WAYNE COLEMAN CONSTR - ALL DEPARTMENTS			\$2,000.00

WEAR PARTS INC

WEAR PARTS INC	Fire-EMS Operations	Equipment for new engines	\$48.89
WEAR PARTS INC	Fire-EMS Operations	Supplies for new engines	\$27.75
<i>WEAR PARTS INC - Total For Fire-EMS Operations</i>			<i>\$76.64</i>
WEAR PARTS INC	Water Meters	Bolts, nuts, washers for marge meters - Met	\$319.40
<i>WEAR PARTS INC - Total For Water Meters</i>			<i>\$319.40</i>
WEAR PARTS INC	WWTP Operations	Clips	\$12.13
<i>WEAR PARTS INC - Total For WWTP Operations</i>			<i>\$12.13</i>
WEAR PARTS INC - ALL DEPARTMENTS			\$408.17

Wear Parts, Inc.

Wear Parts, Inc.	Balefill - Baler Processing	Nuts	\$70.71
<i>Wear Parts, Inc. - Total For Balefill - Baler Processing</i>			<i>\$70.71</i>
Wear Parts, Inc. - ALL DEPARTMENTS			\$70.71

WEST PLAINS ENGINEER

WEST PLAINS ENGINEER	Capital Projects Fund	Ford Wyoming Center Fire Alarm	\$13,000.00
<i>WEST PLAINS ENGINEER - Total For Capital Projects Fund</i>			<i>\$13,000.00</i>
WEST PLAINS ENGINEER	Public Transit - Operations	Elec Design of Parking Lot Lig	\$2,450.00
<i>WEST PLAINS ENGINEER - Total For Public Transit - Operations</i>			<i>\$2,450.00</i>
WEST PLAINS ENGINEER - ALL DEPARTMENTS			\$15,450.00

WEST PUBLISHING CORP

WEST PUBLISHING CORP	City Attorney	Library Plan Charges	\$144.68
WEST PUBLISHING CORP	City Attorney	Online/Software Subscription Charges	\$848.74
<i>WEST PUBLISHING CORP - Total For City Attorney</i>			<i>\$993.42</i>

WEST PUBLISHING CORP - ALL DEPARTMENTS \$993.42

WESTERN STATES FIRE

WESTERN STATES FIRE WWTP Operations Fire system inspection \$290.00

WESTERN STATES FIRE - Total For WWTP Operations \$290.00

WESTERN STATES FIRE - ALL DEPARTMENTS \$290.00

WESTERN WYOMING LOCK

WESTERN WYOMING LOCK Police Administration MISCELLANEOUS PERSONAL SERVICES \$117.56

WESTERN WYOMING LOCK Police Administration MISCELLANEOUS PERSONAL SERVICES \$2.50

WESTERN WYOMING LOCK Police Administration MISCELLANEOUS PERSONAL SERVICES \$70.60

WESTERN WYOMING LOCK - Total For Police Administration \$190.66

WESTERN WYOMING LOCK - ALL DEPARTMENTS \$190.66

WESTLAND PARK-RED BU

WESTLAND PARK-RED BU Sewer Fund Retail Sewer Revenue/201 Sewer Billing/Ad (\$393.10)

WESTLAND PARK-RED BU Sewer Fund Retail Sewer Revenue/201 Sewer Billing/Ad \$3,931.00

WESTLAND PARK-RED BU - Total For Sewer Fund \$3,537.90

WESTLAND PARK-RED BU WWTP Revenue and Transfer Retail Sewer Revenue/201 Sewer Billing/Ad (\$1,855.84)

WESTLAND PARK-RED BU - Total For WWTP Revenue and Transfers (\$1,855.84)

WESTLAND PARK-RED BU - ALL DEPARTMENTS \$1,682.06

WH LLC

WH LLC Capital Projects Fund Ford Wyoming Center South Walk \$1,205.63

WH LLC - Total For Capital Projects Fund \$1,205.63

WH LLC - ALL DEPARTMENTS \$1,205.63

WICKLANDER ZULAWSKI

WICKLANDER ZULAWSKI Police Career Services MANAGEMENT, CONSULTING AND PUBLIC R \$470.00

WICKLANDER ZULAWSKI - Total For Police Career Services \$470.00

WICKLANDER ZULAWSKI - ALL DEPARTMENTS \$470.00

WM SUPERCENTER

WM SUPERCENTER	Balefill - Baler Processing	COFFEE, SUGAR, CREAMER	\$37.08
<i>WM SUPERCENTER - Total For Balefill - Baler Processing</i>			<i>\$37.08</i>
WM SUPERCENTER	Balefill - Diversion & Special	COFFEE, SUGAR, CREAMER	\$6.72
<i>WM SUPERCENTER - Total For Balefill - Diversion & Special</i>			<i>\$6.72</i>
WM SUPERCENTER	City Council	Meeting supplies	\$21.06
<i>WM SUPERCENTER - Total For City Council</i>			<i>\$21.06</i>
WM SUPERCENTER	Metro Animal Control	GROCERY STORES, SUPERMARKETS	\$33.96
<i>WM SUPERCENTER - Total For Metro Animal Control</i>			<i>\$33.96</i>
WM SUPERCENTER	Metro Animal Shelter	GROCERY STORES, SUPERMARKETS	\$7.30
WM SUPERCENTER	Metro Animal Shelter	GROCERY STORES, SUPERMARKETS	\$131.75
<i>WM SUPERCENTER - Total For Metro Animal Shelter</i>			<i>\$139.05</i>
WM SUPERCENTER	Public Transit - CARES Act	GROCERY STORES, SUPERMARKETS	\$42.72
<i>WM SUPERCENTER - Total For Public Transit - CARES Act</i>			<i>\$42.72</i>
WM SUPERCENTER	Water Distribution	Cleaning Materials / Building Materials	\$147.13
WM SUPERCENTER	Water Distribution	HP Paper - Bldg Supplies	\$30.00
<i>WM SUPERCENTER - Total For Water Distribution</i>			<i>\$177.13</i>
WM SUPERCENTER - ALL DEPARTMENTS			\$457.72

WPSG, INC.

WPSG, INC.	Fire-EMS Operations	The Fire Store - Helmet Front	\$80.11
<i>WPSG, INC. - Total For Fire-EMS Operations</i>			<i>\$80.11</i>
WPSG, INC. - ALL DEPARTMENTS			\$80.11

WY. MACHINERY CO.

WY. MACHINERY CO.	Fleet Maintenance Fund	Equipment repair	\$1,662.48
WY. MACHINERY CO.	Fleet Maintenance Fund	Equipment repair	\$3,457.25
WY. MACHINERY CO.	Fleet Maintenance Fund	Equipment repair	\$1,070.33
WY. MACHINERY CO.	Fleet Maintenance Fund	Equipment repair	\$2,768.31
<i>WY. MACHINERY CO. - Total For Fleet Maintenance Fund</i>			<i>\$8,958.37</i>
WY. MACHINERY CO.	Refuse - Recycling	Equipment rental	\$1,256.25
<i>WY. MACHINERY CO. - Total For Refuse - Recycling</i>			<i>\$1,256.25</i>

WY. MACHINERY CO. - ALL DEPARTMENTS

\$10,214.62

WYOMING FINANCIAL PR

WYOMING FINANCIAL PR	Buildings & Structures Fund	Soffe's Mech - invoice #092422-01	\$560.00
----------------------	-----------------------------	-----------------------------------	----------

<i>WYOMING FINANCIAL PR - Total For Buildings & Structures Fund</i>			\$560.00
---	--	--	----------

WYOMING FINANCIAL PR - ALL DEPARTMENTS

\$560.00

WYOMING FIRST AID &

WYOMING FIRST AID &	Metro Animal Shelter	First aid supplies	\$57.18
---------------------	----------------------	--------------------	---------

<i>WYOMING FIRST AID & - Total For Metro Animal Shelter</i>			\$57.18
---	--	--	---------

WYOMING FIRST AID &	Police Administration	First aid supplies	\$68.91
---------------------	-----------------------	--------------------	---------

<i>WYOMING FIRST AID & - Total For Police Administration</i>			\$68.91
--	--	--	---------

WYOMING FIRST AID & - ALL DEPARTMENTS

\$126.09

WYOMING PLANT COMPAN

WYOMING PLANT COMPAN	Parks - Urban Forestry	Tree, planting fee, soil, tree stake & strap	\$354.98
----------------------	------------------------	--	----------

<i>WYOMING PLANT COMPAN - Total For Parks - Urban Forestry</i>			\$354.98
--	--	--	----------

WYOMING PLANT COMPAN	Risk Management	Tree, planting fee, soil, tree stake & strap	\$354.98
----------------------	-----------------	--	----------

<i>WYOMING PLANT COMPAN - Total For Risk Management</i>			\$354.98
---	--	--	----------

WYOMING PLANT COMPAN - ALL DEPARTMENTS

\$709.96

WYOMING STEEL & RECY

WYOMING STEEL & RECY	Balefill - Disposal & Landfill	Angle iron	\$441.23
----------------------	--------------------------------	------------	----------

<i>WYOMING STEEL & RECY - Total For Balefill - Disposal & Landfill</i>			\$441.23
--	--	--	----------

WYOMING STEEL & RECY - ALL DEPARTMENTS

\$441.23

XEROX CORPORATION

XEROX CORPORATION	Regional Water Operations	Copier usage	\$205.66
-------------------	---------------------------	--------------	----------

<i>XEROX CORPORATION - Total For Regional Water Operations</i>			\$205.66
--	--	--	----------

XEROX CORPORATION - ALL DEPARTMENTS

\$205.66

YOUTH CRISIS CENTER

YOUTH CRISIS CENTER	Capital Projects Fund	1%#16 Funding Youth Crisis Cen	\$17,452.50
<i>YOUTH CRISIS CENTER - Total For Capital Projects Fund</i>			<i>\$17,452.50</i>
YOUTH CRISIS CENTER - ALL DEPARTMENTS			\$17,452.50

ZONAR SYSTEMS INC

ZONAR SYSTEMS INC	Refuse - Recycling	Annual Service - 9/15/22 to 4/30/23	\$262.50
<i>ZONAR SYSTEMS INC - Total For Refuse - Recycling</i>			<i>\$262.50</i>
ZONAR SYSTEMS INC	Refuse - Residential	Cables	\$110.73
<i>ZONAR SYSTEMS INC - Total For Refuse - Residential</i>			<i>\$110.73</i>
ZONAR SYSTEMS INC - ALL DEPARTMENTS			\$373.23

CITYWIDE BILLS AND CLAIMS TOTAL **\$3,739,309.80**

I certify, under penalty of perjury, that this listing of vouchers and the items included therein for payment are correct and just in every respect.

SUBMITTED BY (Finance Dir) _____ DATE _____

DULY AUDITED BY (City Manager) _____ DATE _____

APPROVED BY (Mayor) _____ DATE _____

CITY of CASPER, WYOMING
 BILLS and CLAIMS ADDENDUM
 Council Meeting
 10/18/22

Additional Accounts Payable

09/29/22

Prewrits - Travel Reimbursements & Payroll Vendor

First Interstate Bank - Petty Cash (Metro Animal Shelter)	449.66
First Interstate Bank - Petty Cash (Engineering/CPU Admin)	231.00
Life Insurance Company of North America (Cigna)	12,670.80
	13,351.46

10/06/22

Prewrits - Travel Reimbursements, Court Filing Fees, Sales Tax & Payroll Vendor

Luke Iselin - Travel Reimbursement	182.50
Jessica Ostrander - Travel Reimbursement	88.50
Natrona County District Court - Court Filing Fees	120.00
State of Wyo - Dept. of Revenue - Sales tax	1,269.30
Wyo Dept of Workforce Services	103,472.61
	105,132.91

Total Additional AP \$ 118,484.37

October 18, 2022

MEMO TO: City Council
J. Carter Napier, City Manager 

FROM: John Henley, City Attorney 

SUBJECT: An Ordinance Amending Chapter 9.08 - Offenses Against the Person, of the Casper Municipal Code to Add Section 9.08.020 “Malicious Harms Based on Race, Color, Religion, Sex, Sexual Orientation, Gender Identity, Gender Expression, National Origin, or Disability.”

Meeting Type & Date:
Regular Council Meeting
October 18, 2022

Action type:
Establish a Public Hearing to be held on November 1, 2022, regarding An Ordinance Amending Chapter 9.08 - Offenses Against the Person, of the Casper Municipal Code to Add Section 9.08.020 “Malicious Harms Based on Race, Color, Religion, Sex, Sexual Orientation, Gender Identity, Gender Expression, National Origin, or Disability.”

Recommendation:
That City Council to establish the Public Hearing, regarding the above referenced ordinance, to be held on November 1, 2022.

Summary:
The ordinance is based, to a large degree, on a Cheyenne ordinance with the addition of the original and ongoing concerns of the Council’s advisory board, concerning employment, housing, and public accommodations.

There are federal laws addressing employment, housing and public accommodation discrimination, but the reach of those statutes is generally directed at employers with a sizable workforce; the process has no urgency and can take years before a complaint is resolved. (See the *Bostock v. Clayton County, Georgia* bullet points attached two of the three plaintiffs in the three cases heard by the U.S. Supreme Court had already passed away before the Supreme Court decided the issue)

The physical harms included within the proposed ordinance are based upon the current definitions for assault and assault and battery. The difference is that an enhanced penalty is available to the Court upon a first offense. Currently, for a first offense of battery in the Municipal Court, the maximum punishment up to \$750.00. Under the proposed ordinance if the battery was committed because of hate or prejudice against another due to the other’s color, ethnicity, sex, sexual orientation, etc., the municipal judge will have the ability to consider incarceration for a violation proved beyond a reasonable doubt in the Court’s sentencing decision.

City Council discussed the proposed ordinance at the October 12, 2022, Work Session, and requested the Public Hearing to be established for November 1, 2022.

Financial Considerations:

The Casper Police Department will have additional crimes to charge if appropriate, which may take more time to complete. Similarly, charging someone for an offence with possible incarceration may require additional appointments of court appointed attorneys for indigent defendants.

Oversight/Project Responsibility

John Henley, City Attorney's Office

Keith McPheeters, Casper Police Department

Attachments

Proposed ordinance.

Bostock v. Clayton County, Georgia bullet points.

Bostock v. Clayton County, Georgia Bullet Points

- Gerald Bostock worked for Clayton County, Georgia, as a child welfare advocate. Under his leadership, the county won national awards for its work. After a decade with the county, Mr. Bostock began participating in a gay recreational softball league.

Not long after that, influential members of the community allegedly made disparaging comments about Mr. Bostock's sexual orientation and participation in the league. Soon, he was fired for conduct "unbecoming" a county employee.

- Donald Zarda worked as a skydiving instructor at Altitude Express in New York. After several seasons with the company, Mr. Zarda mentioned that he was gay and, days later, was fired.
- Aimee Stephens worked at a funeral home in Garden City, Michigan. When Stephens got the job, Stephens presented as a male.

But two years into service with the company, Stephens began treatment for despair and loneliness. Ultimately, clinicians diagnosed Stephens with gender dysphoria and recommended that Stephens begin living as a woman.

In Stephens sixth year with the company, Stephens wrote a letter to the employer explaining that Stevens planned to "live and work fulltime as a woman" after Stephens returned from an upcoming vacation. The funeral home fired Stevens before Stephens left, telling Stephens "this is not going to work out."

Federal Civil Rights Act 9.02[2][a]:

The term "employer" for federal actions means a person engaged in an industry who has fifteen or more employees.

ORDINANCE NO.

AN ORDINANCE AMENDING CHAPTER 9.08 – OFFENSES AGAINST THE PERSON, OF THE CASPER MUNICIPAL CODE TO ADD SECTION 9.08.020 “MALICIOUS HARMS BASED ON RACE, COLOR, RELIGION, SEX, SEXUAL ORIENTATION, GENDER IDENTITY, GENDER EXPRESSION, NATIONAL ORIGIN, OR DISABILITY.”

WHEREAS, the governing body of the City of Casper has the authority granted by Wyoming State Statute §15-1-103(a)(xviii), xvi(C) and (xli) to adopt ordinances and resolutions necessary to protect the health, safety and welfare of the City and of its citizenry; and,

WHEREAS, the governing body of the City of Casper may perform acts authorized by the powers granted by the state in relation to the concerns of the city; and,

WHEREAS, the City of Casper is composed of and welcomes diverse individuals, groups and communities; and,

WHEREAS, the City of Casper values diversity and seeks to encourage and allow all residents and visitors to contribute to the commercial life and activities of the City and to the cultural and social life of the City; and,

WHEREAS, affirming nondiscrimination protections and investing in social safety will help reduce vulnerable communities’ exposure to potential violence, economic injury and discrimination; and,

WHEREAS, the governing body of the City of Casper desires to amend Chapter 9.08 – of the Casper Municipal Code by creating Section 9.08.020.

NOW, THEREFORE, BE IT ORDAINED BY THE GOVERNING BODY OF THE CITY OF CASPER, WYOMING: that Section 9.08.020 is created and shall be codified as follows:

Section 9.08.020 Malicious harms based on race, color, religion, sex, sexual orientation, gender identity, gender expression, national origin, or disability.

A. Unlawful physical actions committed on the basis of protected characteristics

It shall be unlawful and an offense for any person to commit any of the following acts maliciously and with the specific intent to intimidate or harm another person because of that person’s race, color, religion, ancestry, sex, sexual orientation, gender identity, gender expression, national origin, or disability (hereafter collectively “protected characteristics”):

1. a. **Assault of another.** Whoever, having the present ability to do so, attempts to commit a violent injury on another person because of one or more protected characteristics of that person, is guilty of an assault under this section.

b. **Assault and Battery of that person.** Whoever, in a rude, insolent or angry manner, unlawfully touches another person because of one or more protected characteristics of that person, is guilty of an assault and battery under this section.

2. **Injuring, defacing or destroying property of another.** No person shall (a) willfully injure, deface or destroy, or attempt to injure, deface or destroy, any other person's building or any fixture thereof, (b) injure, destroy or secrete any goods, chattels or valuable papers of any other person, (c) injure, deface, or destroy any fence, foundation, sidewalk, trees or any other private property of any other person without permission, or (d) damage, destroy, vandalize, deface, trespass upon, or steal any real or personal property of any other person because of one or more protected characteristics of that person, is guilty of injuring, defacing or destroying property of another under this section.

B. Inciting imminent lawless violence against another.

It shall be unlawful and a violation hereof for any person, by words, depictions or actions, to incite or produce imminent lawless violence directed against another person because of one or more protected characteristics of that person, including circumstances in which such words, depictions, or actions were intended and likely to incite or produce such imminent lawless violence, but failed in their objective.

C. Places of public accommodation; discrimination prohibited.

It shall be unlawful and an offense for any person, with malice or prejudice, to restrict another person from obtaining the full and equal enjoyment of the goods, services, facilities, privileges, advantages and accommodations of any place of public accommodation because of one or more protected characteristics of that person. For purposes of this paragraph, "place of public accommodation" means, businesses, and locations which are open to the public., or which invite the patronage of the public.

D. Housing; illegal discrimination prohibited.

It shall be unlawful for any person or entity to discriminate against another person in the sale, lease, or rental of any housing facility, or to otherwise discriminate against such person in the terms, conditions, maintenance, improvement, or repair of any housing facility, because of one or more protected characteristics of that person.

E. Employment discrimination prohibited.

1. It shall be unlawful and an offense for any employer to refuse to hire or promote a person, or to discriminate against a person in matters of compensation or the terms, conditions or privileges of employment, because of one or more protected characteristics of that person.
2. It shall be unlawful and an offense for any person, an employer, an employment agency, a labor organization, or its employees or members, to discriminate in matters of employment or membership, including customary benefits of the employment membership, against a qualified person, because of one or more protected characteristics of that person.
3. It shall be unlawful and an offense for an employer to reduce the wage or benefits of any employee because of one or more protected characteristics of that person.

F. 1. Exceptions. Notwithstanding anything contained in this Section, the following practices shall not be a violation of this Section:

- a. Any action or right authorized or protected by the Religious Freedom Restoration Act (42 U.S.C. § 2000bb – 2000bb-4), Wyoming Statutes, the United States Code, the United States Constitution, or the Wyoming Constitution.
- b. For a religious organization or institution to restrict any of its facilities of housing or accommodations which are operated as a direct part of religious activities to individuals of the religious organization or institution involved or to restrict employment opportunities for officers, religious instructors and clergy to individuals of that religious organization or institution.
- c. For the owner of an owner-occupied one-family or two-family dwelling, or a housing facility or public accommodation facility, respectively, devoted entirely to the housing and accommodation of individuals of one sex, to restrict occupancy and use on the basis of sex.
- d. To discriminate in any arrangement for the sharing of a dwelling unit by an individual who is sharing the unit.

2. Exceptions. Notwithstanding anything contained in this Section, the following entities or their agencies shall not be prosecuted pursuant to Subsections C., D., and E., of this Section:

- a. The United States or any department or agency thereof, a corporation wholly owned by the government of the United States or Indian Tribe;
- b. The State of Wyoming or any department or agency thereof, including any political subdivision of the State;
- c. A bona fide private membership club (other than a labor organization) which is exempt from taxation under the Internal Revenue Code of 1986; or,

- d. A fraternal or religious association or corporation if the association or corporation is neither organized for private profit nor has as its primary purpose the provision of accommodations or services that are available on a non-membership basis.
- e. An institution, club, or place of accommodation that proves that it is, by its nature, distinctly private. An institution, club, or place of accommodation is not by its nature distinctly private if:
 - i. It has more than twenty-five) members, and
 - ii. Provides regular meal service, and
 - iii. Regularly receives payment for dues, fees, use of space, facilities, services, meals, or beverages, directly or indirectly, from or on behalf of members. For the purposes of this definition, any lodge of a recognized national fraternal organization is considered by its nature distinctly private.

G. Burden of proof. Investigations of alleged violations of this code are undertaken based upon a strong showing of reasonable suspicion that the violation occurred because the alleged perpetrator's actions were based on one or more protected characteristics of the victim(s). Reasonable suspicion is best demonstrated by expressions of bias, hate or prejudice, made or encouraged by the perpetrator at or near the time of the alleged violation, or, through a sustained pattern of conduct which demonstrates the perpetrator's motivation. Violations of this code section, must be proved beyond a reasonable doubt .

H. Penalty.

- 1. Any person found guilty of violating subsections A. and/or B., of this section, may be punished by a fine up to \$750.00 or up to six (6) months in jail, or both.
- 2. Any person found guilty of violating the subsections C., D., or E., of this section, may be punished by a fine up to \$750.00, under the general provisions of Section 1.28.010 of the Casper City Code.

**The remainder of this page is intentionally left blank **

PASSED on 1st reading the ____ day of _____, 2022.

PASSED on 2nd reading the ____ day of _____, 2022.

PASSED, APPROVED, AND ADOPTED on third and final reading the _____ day of _____, 2022.

APPROVED AS TO FORM:

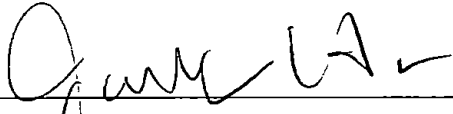

ATTEST:

CITY OF CASPER, WYOMING
A Municipal Corporation

Fleur Tremel
City Clerk

Ray Pacheco
Mayor

October 17, 2022

MEMO TO: J. Carter Napier, City Manager

FROM: Shane Chaney, Deputy Police Chief 

SUBJECT: Cancel October 18, 2022, a Public Hearing Regarding Proposed Changes to City of Casper Ordinances, Chapter 8.08, Private Intrusion Alarms, and Re-establish the Date of Public Hearing as November 1, 2022

Meeting Type & Date

November 1, 2022

Action type

Minute Action

Recommendation

That Council, by minute action, cancels the October 18, 2022, public hearing, and re-establish November 1, 2022, as the date of the public hearing for the consideration of changes to the City of Casper Municipal Ordinances, Chapter 8.08, Private Intrusion Alarms.

Summary

On average, the Casper Police Department responds to approximately 1,200 private intrusion alarms a year. These calls for police response require a minimum of two officers, in addition to occupying the time and concentration of multiple dispatchers as well. Despite these public safety efforts and the necessary allocation of these resources, 99.2% of all private intrusion alarms are later determined to be “false.” Since 2017, the Patrol Division of the Casper Police Department has devoted an estimated 3,169 hours responding to false alarms.

It is the recommendation of the Casper Police Department that, rather than attempting edits to our existing ordinances in Chapter 8.08, we adopt and adapt the IACP model ordinance to the needs of our community.

An error occurred with the required legal notice/publication, and staff is requesting that the public hearing be canceled and re-established for November 1, 2022.

Financial Considerations

Not Applicable

Oversight/Project Responsibility

Keith McPheeters, Police Chief

Attachments

Draft Private Intrusion, Robbery, Hold-up, Duress, and Panic Alarms Resolution and Ordinance.

ORDINANCE NO. 17-22

AN ORDINANCE REPEALING AND REPLACING
ORDINANCE NO. 16-97 CODIFIED AS CHAPTER 8.08 OF THE
CASPER MUNICIPAL CODE.

WHEREAS, the governing body of the City of Casper has the authority granted by Wyoming State Statute §15-1-103(a)(xiii) and (xli) to adopt ordinances and resolutions necessary to protect the health, safety and welfare of the City and of its citizens; and,

WHEREAS, the governing body of the City of Casper may perform all acts in relation to the concerns of the city necessary to the exercise of its corporate powers; and,

WHEREAS, the Casper Municipal Code needs updated and modified from time to time; and,

WHEREAS, this ordinance addresses the finding that excessive false alarms unduly burden the Casper Police Department's law enforcement resources; and,

WHEREAS, the purpose of this ordinance is to establish reasonable standards for users, to ensure that alarm owners are held responsible for the proper operation of their alarm systems; and,

WHEREAS, Public Safety agencies recognize the significant burdens placed on local law enforcement resources due to responding to false alarm calls; and,

WHEREAS, properly installed, monitored and operated alarm systems are effective tools which can identify criminal offenses in progress, and will lead to a reduction in the incidents of false alarms as well as enhance the safety of responding law enforcement officers; and,

WHEREAS, reduction of false alarms and clearly defined alarm user responsibilities are to the benefit of all parties.

NOW THEREFORE, BE IT ORDAINED BY THE GOVERNING BODY OF
THE CITY OF CASPER, WYOMING:

Section 1. Ordinance No. 16-97 as codified in the Casper Municipal Code as Chapter 8.08, Sections 8.08.010 through 8.08.170 is hereby repealed and replaced with this Ordinance and should be codified as set out in Section 2, below.

Section 2. This Ordinance is established to set reasonable standards for users, ensure that alarm owners are held responsible for their use of alarm systems, and to encourage the use of efficient security systems in accordance with established best practices and shall be codified as Chapter

8.08 of the Casper Municipal Code, titled “Private Intrusion, Robbery, Hold-up, Duress, and Panic Alarms Ordinance,” as follows:

8.08.010 Title

This Chapter shall be referred to as the “Private Intrusion, Robbery, Hold-up, Duress, and Panic Alarms Ordinance.”

8.08.020 Purpose

The purpose of this chapter is to set forth regulations governing private intrusion, robbery, hold-up, duress, and panic alarm systems within the City; to reduce the dangers and diversions of false alarms; to require registration of alarm systems and encourage alarm users to maintain their systems in good working order; to encourage alarm system users to use their systems properly; and to provide the authority to establish fees.

8.08.030 Definitions

The following words, terms, and phrases, when used in this Ordinance, shall have the meanings ascribed to them, except where the context clearly indicates a different meaning:

- A. “Alarm Administrator” means a person or persons designated by the City to administer the provisions of this Ordinance.
- B. “Alarm Company” means a person, company, firm, or corporation, which has the contractual agreement with the alarm user and is subject to the licensing requirements promulgated by the City, and who is engaged in selling, leasing, installing, servicing or monitoring alarm systems; this entity shall be licensed in compliance with city, county and state laws.
- C. “Alarm Event” means an alarm system activation, to which law enforcement is requested to respond.
- D. “Alarm permit” means a permit issued to an alarm user by the City allowing the operation of an alarm system, which, as a function of its design and purpose, is the basis of a notification to the police that a police response is required or expected within the City.
- E. “Alarm system” means an assembly of equipment installed at a fixed location designed to detect and/or verify an occurrence of an illegal or unauthorized entry or other activity to which law enforcement is requested to respond.
- F. “Alarm user” means any person, corporation, partnership, proprietorship, governmental or educational entity or any other entity owning, leasing, or operating an alarm system, or

on whose premises an alarm system is maintained for the protection of such premises or the occupants therein.

- G. “Alarm User Awareness Class” means a class conducted for the purpose of educating alarm users about the responsible use, operation, maintenance of alarm systems and effective verification of alarms, and false alarm reduction strategies.
- H. “Cancellation” means that the alarm company provides notification that response by law enforcement is no longer being requested. If cancellation occurs prior to law enforcement arrival at the scene, this is not a false alarm for the purpose of civil penalty, and no penalty will be assessed.
- I. “Certified Alarm Technician” means a person holding a current and up-to-date designation or certification by the Electronic Security Association, or an equivalent certification from a national alarm industry organization or alarm equipment manufacturer.
- J. “City” means the City of Casper, or its agent.
- K. “Compliance Standards” means equipment and installation methods shall comply with all appropriate nationally recognized testing laboratories and American National Standards Institute (ANSI) requirements.
- L. “Do It Yourself/Monitor It Yourself (DIY/MIY) Systems” means all alarm systems installed, activated, utilized, or monitored by the user without the assistance of an Alarm Company or service. All such systems shall adhere to all requirements of this alarm Ordinance, regardless if the system is a “do it yourself” and/or “monitor it yourself.”
- M. “Dual-Activation Robbery/Hold-up Device” means a device which requires that two buttons be depressed together to activate an alarm signal for an in-progress robbery, hold-up, duress, or panic causing situation.
- N. “Enhanced Call Confirmation” means an attempt by the alarm system monitoring company to contact the alarm site and/or alarm user, to determine whether an alarm event is valid before requesting law enforcement response. A second attempt will be made to contact the alarm user if the first attempt fails. EXCEPT:
 - 1. As defined by ANSI/CSAA CS V 01 2016 or current version, in case of a fire, panic, robbery-in-progress alarm or verified alarm.
- O. “False alarm” means the activation of an alarm system when, upon observation by Law Enforcement, there is no evidence of unauthorized entry, robbery, or other such crime attempted in or on the premises. False alarm does not include alarms activated by violent conditions of nature, such as blizzards, tornadoes, earthquakes, or any other similar causes beyond the control of the user of an alarm system. False alarms generated by incorrect system installation or by inappropriate or overly-sensitive alarm system settings, which are

triggered by reasonably anticipated, or regionally common weather-related events or other similar minor acts of nature, shall not be exempt from designation as a false alarm.

- P. "Local alarm" means an alarm system that is not monitored by a remote monitoring center.
- Q. "Permit year means" a 12-month, calendar year period, beginning on the day and month on which an alarm permit is issued and ending on December 31st of the year in which the permit was issued.
- R. "Robbery", hold-up, duress, or panic alarm" means any alarm system or alarm function which is designed to report an incident involving the immediate and currently occurring jeopardy of human life due to criminal acts of violent crime such as those associated with armed robbery, hold-ups, kidnapping, and similar acts of criminal violence.
- S. "Runaway alarm" means an alarm system that produces repeated alarm activations that do not appear to be caused by separate human action. Law Enforcement may, in its discretion, discontinue police responses to alarm activations from what appears to be a runaway alarm.

8.08.040 Alarm Registration, Permitting, and Permit Fees

- A. **Permit required.** No person shall use an alarm system without first obtaining a permit from the City for that alarm system. A fee may be required for the initial registration and annual renewals. Each alarm permit shall be assigned a unique permit number, and the user shall provide the permit number to the alarm company to facilitate law enforcement dispatch. Permits are issued for a calendar year and are subject to renewal prior to the commencement of any subsequent calendar year.
- B. **Application.** The permit shall be requested on an application form provided by the City. An alarm user has the duty to obtain an application from the City. The Application shall include the full name, address, and phone number of at least three (3) responsible persons authorized to exercise control over the operations of the intended alarm system and the required response, upon request of responding law enforcement personnel, to alarm activations. For new residential alarm permit applicants who are new to the City, and who may not yet know or have the required three (3) responsible persons authorized to exercise control over the alarm, it is permissible to submit application for the initial calendar year permit with less than three (3) responsible persons.
- C. **Transfer of possession.** When the possession of the premises at which an alarm system is maintained or operated is transferred, the person (user) obtaining possession of the property shall file an application for an alarm permit within 30 (thirty) days of obtaining possession of the property. Alarm permits are not transferable.
- D. **Annual Renewal of Alarm Permit.** No later than January 1st of each year, renewing alarm permit holders shall provide an alarm permit renewal application to the City along with the associated permit renewal fee. The annual alarm permit renewal shall provide verification

that the list of responsible persons authorized to exercise control over the operations of the alarm system is accurate and up-to-date.

- E. **Reporting updated information.** Whenever the required information provided on the alarm permit application changes, including the contact information for the three responsible persons authorized to exercise control over the alarm, the alarm user shall provide corrected information to the City within 30 (thirty) days of the change. In addition, at the beginning of each calendar year after the issuance of the permit, permit holders will receive from the City a form requesting updated information. The permit holder shall complete and return this form to the City whether or not any of the requested information has changed. Failure to provide updated information and verification of information upon annual renewal will constitute a violation of this Ordinance and shall result in a civil penalty. The inability to contact responsible persons authorized to exercise control over the alarm system due to outdated, invalid, or incorrect contact information, as provided and maintained by the alarm user with the permit application, update, or renewal, shall constitute *prima facie* evidence of a violation of this Ordinance.
- F. **Multiple alarm systems.** If an alarm user has one (1) or more alarm systems protecting two (2) or more separate structures having different addresses and/or tenants, a separate permit shall be required for each structure and/or tenant.
- G. **Alarm system installers.** The name of the service provider that installed the system, or if installed by the alarm user DIY (“do it yourself”), shall be indicated on the permit application by the applicant.
- H. **Monitoring Agency.** The name of the monitoring station that is monitoring the alarm system, or, if it is to be monitored by the alarm user MIY (“monitor it yourself”), shall be indicated on the permit application by the applicant.
- I. **Permit Fees.** The commercial and residential properties alarm permit fee is Twenty-Five Dollars (\$25.00), per permit, per calendar year. A new permit for the sole purpose of notification to the City of changes to an alarm system or its responsible persons contact information will not require a renewal fee for that year.
- J. **Annual Permit Renewal Required.** Police response to a property without a valid annual renewal will be subject to the same fee as failing to register.
- K. **Alarm Company Permit.** All Alarm Companies shall obtain an Alarm Company Permit from the City, the fee for which will be One-Hundred Dollars (\$100.00), per calendar year. Renewal of Alarm Company Permits shall occur no later than January 1 of the new calendar year and are valid for the duration of the calendar year. The Alarm Company Permit application and renewal shall contain current contact information for the persons responsible for the Alarm Company as well as a current list of all certified alarm technicians performing work for them.

8.08.050 Duties of the Alarm User

- A. Maintain the premises and the alarm system in a method that will reduce or eliminate false alarms.
- B. Provide the alarm company the permit number, (the number must be provided to the communications center by the alarm company to facilitate dispatch).
- C. Respond or cause a representative to respond to the alarm system’s location within a reasonable amount of time, not to exceed twenty (20) minutes, upon notification and request by the Casper Police Department.
- D. Not manually activate an alarm for any reason other than an occurrence of an event that the alarm system was intended to report.
- E. An alarm user must obtain a new permit and pay any associated fees if there is a change in address or ownership of the location of the alarm-system.
- F. An alarm user must keep current the annual renewal of the alarm permit as well as provide, within thirty (30) days of any change, any update for any required contact information for the three responsible persons for the alarm system.
- G. An alarm user that installs the alarm system themselves (Do It Yourself, or DIY) or who will be monitoring the alarm system themselves (Monitor It Yourself, or MIY) is subject to the same duties as described in paragraph (A), (D), (E), (F), (H), and (I) of 8.08.060.

8.08.060 Duties of the Alarm Company

- A. Any alarm system installed within the City after the effective date of this Ordinance shall be equipped with an uninterrupted power supply in such a manner that failure of, or interruption of, normal electric service will not activate the alarm. The uninterruptable, back-up power supply shall be capable of providing, at a minimum, at least four (4) hours of operation.
- B. Every person performing alarm installation or alarm servicing for a permitted Alarm Company shall be a certified alarm technician or be in training to become a certified alarm technician. Any person in training to become a certified alarm technician shall have his or her work and final product supervised, inspected, and approved by a certified alarm technician working for the same Alarm Company.
- C. Any person engaged in the alarm business in the city shall comply with the following:
 - 1. Obtain and maintain any required state, county and/or city license(s).
 - 2. Provide name, address, and telephone numbers of the alarm company license holder or a designee who can be called in an emergency, twenty-four (24) hours

a day; and be able to respond to an alarm call, when notified, within a reasonable amount of time.

3. Be able to provide the most current contact information for the alarm user; and to contact a key holder for a response, if requested.
- D. No alarm company, or any employee of an alarm company, or self-monitoring alarm system user shall make a false statement to the alarm administrator.
- E. No alarm salesperson, alarm service person, or alarm installer shall activate an alarm signal that results in a false alarm reported to the police.
- F. Prior to activation of the alarm system, the alarm company must provide instructions explaining the proper operation of the alarm system to the alarm user(s).
- G. Provide information to the alarm user on how to obtain service from the alarm company for the alarm system.
- H. Upon enactment of this Ordinance, alarm installation companies shall, on all new and upgraded installations, install or provide only devices which require dual-activation of a two-button alarm activation function on any device(s) to be used for the purpose of reporting a robbery, hold-up, duress, or panic situation for any application in any commercial or residential account.
- I. An alarm company responsible for monitoring services shall:
 1. Ensure the monitoring center utilizes Enhanced Call Confirmation. The monitoring center shall make two (2) attempts to contact user or users of alarm system prior to requesting law enforcement response.
 2. Provide alarm user registration number to the communications center to facilitate dispatch and/or cancellations.
 3. Communicate any available information regarding specifics of the alarm event.
 4. Communicate a cancellation to the law enforcement communications center as soon as possible following a determination that a police response is unnecessary.

8.08.070 Duties of the Law Enforcement upon Response to an Alarm Activation

- A. Upon arrival at the site of an alarm activation of an alarm system, responding law enforcement officers shall make reasonable effort to determine if the alarm activation was a result of criminal activity, attempted criminal activity, or other emergency situation.
- B. Upon the reasonable determination that an alarm activation meets the definition of a false alarm, a responding officer shall leave written notification of the false alarm response at

the site of the alarm activation, as is reasonably possible given the conditions and circumstances present at the alarm activation site.

- C. Upon the issuance of a notification of a false alarm response, a copy of the notification shall be mailed to the alarm user listed on the alarm permit application.

8.08.080 Prohibited Acts

- A. It shall be a violation of this Ordinance to activate an alarm system for the purpose of summoning law enforcement when no private intrusion, burglary, robbery, or other crime dangerous to life or property is being committed, or attempting to be committed, or to otherwise cause a false alarm.
- B. It shall be a violation of this Ordinance to install, maintain, or use an external, audible alarm system which can sound continually for more than 10 minutes.

8.08.090 Excessive False Private Alarms; Fees and Suspensions Therefor

- A. **Excessive false private intrusion alarms; fees.** It is hereby found and determined that three (3) or more false private intrusion alarms within a permit year is excessive and shall be a violation of this Ordinance.
 - 1. Civil fees and constraints around police response for false private intrusion alarms within a permit year shall be assessed against an alarm user as follows:

Third false alarm	\$ 75.00
Fourth false alarm	\$150.00
Fifth false alarm	\$250.00
Sixth and subsequent false alarm	\$500.00

- B. **Excessive false robbery, hold-up, duress, or panic alarms; fees.** It is hereby found and determined that the nature and intent of robbery, hold-up, duress, or panic alarms is to summon emergency personnel to the scene of the alarm for an apparent immediate jeopardy to human life, and that, as such, it is common that such alarms create a significant commitment of emergency personnel and resources. Further, it is hereby found and determined that excessive false robbery, hold-up, duress, and panic alarms create additional drain on public safety resources and should therefore be treated with the gravity such unwarranted resource allocations adversely cause to public safety. Therefore, it is hereby found and determined that two or more, false robbery, hold-up, duress, or panic alarms within a permit year is excessive and shall be a violation of this Ordinance.
 - 1. Civil fees and constraints around police response for false robbery, hold-up, duress, or panic alarms within a permit year may be assessed against an alarm user as follows:

Second false alarm	\$250.00
Third false alarm	\$500.00
Fourth and subsequent false alarm	\$750.00

C. Suspension of law enforcement response – Excessive false alarms. After an alarm site has accumulated eight (8) false alarm responses in a twelve (12) month alarm permit period, the Alarm Administrator shall notify the alarm user, the alarm installation company, or monitoring company, in writing, at least thirty (30) calendar days before police response to an alarm system’s notifications is to be discontinued. Suspension of alarm response does not apply to duress, robbery, holdup, and panic alarms. The notice of suspension must also include the amount of the penalty amount for each false alarm, and a description of the appeals procedure available to the alarm user and the alarm installation company or monitoring company.

D. Reinstatement of suspended sites for excessive false alarms. A person whose alarm permit has been suspended may obtain reinstatement of the permit by the Alarm Administrator if the person submits to the Alarm Administrator:

1. A \$25.00 reinstatement fee.
2. Sufficient demonstration and articulation, in writing, addressing proactive measures which have been implemented to prevent false alarms in the future.
3. Certification from an alarm installation company stating that the alarm has been inspected and/or repaired for any case where repetitive, obvious malfunctioning of the system or the system’s settings has occurred.

E. Reinstatement of response. The Police Department shall reinstate its response to an alarm site as soon as practical, after receiving notice of reinstatement from the Alarm Administrator. Reinstatement of police response to an alarm pursuant to these procedures does not constitute a new permit for the purpose of calculating the fees associated with police responses to a false alarm during the calendar permit year. Subsequent responses to false alarms shall be assessed fees in accordance with the total number of previous false alarms during the calendar permit year.

F. Additional suspension of service. If an alarm permit is reinstated after suspension, the Police Department may again discontinue service if it is determined that two (2) false alarms have occurred within sixty (60) days after the reinstatement date. Notification of any such additional discontinuation of service shall be delivered to the alarm user, the alarm installation company, or monitoring company, in writing, at least thirty (30) calendar days before police response to an alarm system’s notifications is to be discontinued. Suspension of alarm response does not apply to duress, robbery, holdup, and panic alarms.

G. Alarm Administrator discretion. In the Alarm Administrator's sole discretion, the Alarm Administrator may waive required alarm inspection certification or alarm user training prior to approving reinstatement, and may reduce or waive false alarm fees, as appropriate. The Alarm Administrator's decision to approve or deny reinstatement, or to reduce or waive

fees, shall be made to further the efficient use of Police Department resources and in the interests of the public's health, safety and welfare.

8.08.100 Civil Fees and Penalties for Administrative Violations

- A. Violations of any portion of this Chapter's administrative requirements are subject to the following civil penalties and fees:
 - 1. Failure to Register for an Alarm Permit \$100.00
 - 2. Failure to Renew an Operating or Active Alarm Permit \$100.00
 - 3. Failure to Update Contact Information for Responsible Alarm Users within 30 Days of any Change or at Permit Renewal \$100.00
- B. Other Civil Penalties. Violations will be enforced through the assessment of civil penalties in the amount of One Hundred Dollars (\$100.00) per violation.
- C. Payment of Civil Penalties. Civil penalties shall be paid within (30) days from the date of the invoice.
 - 1. Discontinuance of law enforcement response. The failure of an alarm user to make payment of any civil penalties assessed under this Ordinance, within 60 days from the date of the invoice, may result in discontinuance of law enforcement response to alarm signals that may occur at the premises described in the alarm user's permit, until payment is received. This provision does not apply to any alarm sites for panic/duress alarm activations or robbery/hold up alarms even though the site is suspended.
- D. Civil Non-criminal violation.

A violation of any of the provisions of this Ordinance shall be a civil violation and shall not constitute a criminal, misdemeanor infraction.

8.08.120 Alarm User Awareness Class.

- A. The City may establish an Alarm User Awareness Class and may request the assistance of the area alarm companies to assist in developing and conducting the class. The class shall inform alarm users of the problems created by false alarms and instruct alarm users how to help reduce false alarms. The City may grant the option of attending an educational class in lieu of paying one assessed fine, not to exceed One Hundred Dollars (\$100.00). As part of this class, information pertaining to security systems that may also provide a verified alarm to the police shall be provided.
- B. Alternatively, the class can be delivered to the user as an online training module.

- C. Upon submission to the Alarm Administrator proof of a successful attendance and completion of such a class, the Alarm Administrator shall waive any penalty or fee, not to exceed One Hundred Dollars (\$100.00).

8.08.130 Appeals Process.

- A. Assessments of civil penalties and other enforcement decisions made under this Ordinance may be appealed by filing a written notice of appeal with the Casper Police Department within thirty (30) days after the date of notification of the assessment of civil penalties or other enforcement decision. The failure to give written notice of appeal within this time period shall constitute a waiver of the right to contest the assessment of a penalty, or penalties, or other enforcement decision. Appeals shall be heard using the contested case format of the Wyoming Administrative Procedures Act. The hearing officer's decision is subject to review in the district court by proceedings in the nature of certiorari.
- B. The hearing officer shall review an appeal from the assessment of civil penalties or other enforcement decisions using a preponderance of the evidence standard. Notwithstanding a determination that the preponderance of the evidence supports the assessment of civil penalties or other enforcement decision, the hearing officer shall have the discretion to dismiss or reduce civil penalties or reverse any other enforcement decision, where warranted.

8.08.140 Confidentiality

In the interest of public safety, all information contained in and gathered through the alarm registration applications, no response records, applications for appeals and any other alarm records shall be held in confidence by all employees and/or representatives of the City.

8.08.160 Government Immunity

Alarm registration is not intended to, nor will it, create a contract, duty or obligation, either expressed or implied, of response to any alarm, nor for the timeliness thereof. Any, and all, liability and consequential damage resulting from the failure to respond to a notification is hereby disclaimed and governmental immunity as provided by law is retained. By applying for an alarm registration, the alarm user acknowledges that the Casper Police Department's response may be influenced or negated by factors such as the availability of police units, priority of calls, weather conditions, traffic conditions, emergency conditions, staffing levels, and prior response history.

8.08.180 Severability

The provisions of this Ordinance are severable. If a court determines that a word, phrase, clause, sentence, paragraph, subsection, section, or other provision is invalid or that the application of any

part of the provision to any person or circumstance is invalid, the remaining provisions and the application of those provisions to other persons or circumstances are not affected by that decision.

This Ordinance shall become in full force and effect twenty-one (21) days after passage on third reading and publication.

The remainder of this page is intentionally left blank

PASSED on 1st reading the ____ day of _____, 2022

PASSED on 2nd reading the ____ day of _____, 2022

PASSED, APPROVED, AND ADOPTED on third and final reading the ____ day of _____, 2022.

APPROVED AS TO FORM:

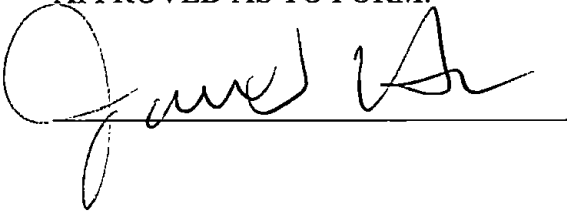

A handwritten signature in black ink, appearing to read 'Fleur Tremel', is written over a horizontal line.

ATTEST:

CITY OF CASPER, WYOMING
A Municipal Corporation

Fleur Tremel
City Clerk

Ray Pacheco
Mayor

ORDINANCE NO. 15-22

AN ORDINANCE APPROVING A PARTIAL PLAT VACATION, REPLAT, VACATION OF PUBLIC PARKLAND AND ZONE CHANGE FOR THE NORTH PLATTE RIVER PARK NO. 2 SUBDIVISION IN THE CITY OF CASPER, WYOMING.

WHEREAS, an application has been made to vacate and replat a portion of Tract 4, North Platte River Park Subdivision to create North Platte River Park No. 2, comprising 185-acres, more or less, and located generally northwest of the Events Center, and including the Events Center parcel; and,

WHEREAS, Lots 1 and 2, North Platte River Park No. 2 are proposed to be vacated from public use for park purposes, pursuant to W.S. §15-1-103(a)(xii); and,

WHEREAS, pursuant to W.S. §15-7-303, notice of the hearing for consideration of the vacation of park property from public use has been published for three (3) consecutive weeks prior to the public hearing in the Casper Star Tribune; and,

WHEREAS an application has been made to rezone proposed Lots 1 and 2, North Platte River Park No. 2 from PH (Park Historic) to M-1 (Limited Industrial) and M-2 (General Industrial) respectively; and,

WHEREAS, the requested partial plat vacation, replat, vacation of public parkland and rezoning requires approval by ordinance, following a public hearing; and,

WHEREAS, after a public hearing on November 18, 2021, the City of Casper Planning and Zoning Commission passed a motion recommending that City Council approve the proposal; and,

WHEREAS, the governing body of the City of Casper finds that the above described partial vacation of plat, replat, vacation of public parkland, and zone change, should be approved.

NOW, THEREFORE, BE IT ORDAINED BY THE GOVERNING BODY OF THE CITY OF CASPER, WYOMING:

SECTION 1:

The partial plat vacation and replat creating the North Platte River Park No. 2 Addition is hereby approved.

SECTION 2:

The vacation of proposed Lots 1 and 2, North Platte River Park No. 2 Addition from public use as park property is found to be in the public interest; notice of the public hearing has been published for three (3) consecutive weeks; the City has owned the property for more than ten (10) years, and no substantial use has been made thereof for park purposes. Therefore, said lots are hereby vacated from public use as park property.

SECTION 3:

The zoning of North Platte River Park No. 2 Addition shall be as follows:

- Lot 1 - M-2 (General Industrial);
- Lot 2 – M-1 (Limited Industrial);
- Lot 3 – (will remain zoned as PH (Park Historic))

SECTION 4:

This ordinance shall be in full force and effect from and after passage on three readings and publication pursuant to law.

PASSED on 1st reading the 20th day of Sept., 2022.

PASSED on 2nd reading the ____ day of _____, 202 .

PASSED, APPROVED, AND ADOPTED on 3rd and final reading the ____ day of _____, 20 .

APPROVED AS TO FORM:

Walter Trout

ATTEST:

CITY OF CASPER, WYOMING
A Municipal Corporation

Fleur Tremel
City Clerk

Ray Pacheco
Mayor

Proposed North Platte River Park No. 2 Subdivision

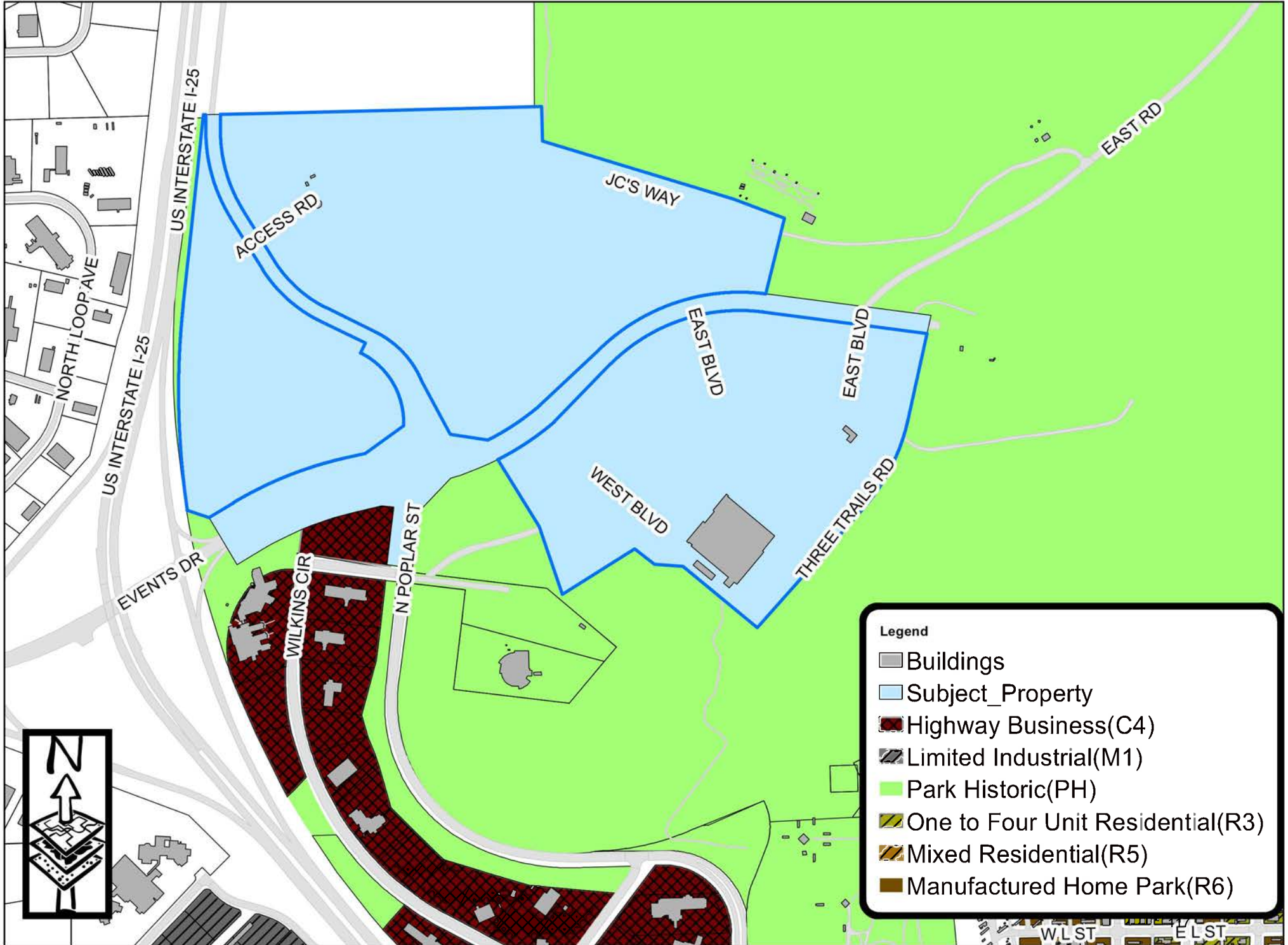

Proposed North Platte River Park No. 2 Subdivision



CERTIFICATE OF DEDICATION

STATE OF WYOMING }
COUNTY OF NATRONA }SS

THE UNDERSIGNED, STEVEN K. FREEL, AS MAYOR OF THE CITY OF CASPER, DOES HEREBY CERTIFY THAT THEY ARE THE OWNERS AND PROPRIETORS OF THE FOLLOWING DESCRIBED PARCEL OF LAND BEING A PORTION OF TRACT 4, NORTH PLATTE RIVER PARK, RECORDED AS INSTRUMENT NO. 266227, ON JUNE 28, 1979 AND SITUATE IN THE S½E½ AND THE N½E½ OF SECTION 32, AND THE S½W½ AND THE N½W½ OF SECTION 33, T.34N., R.79W., 6TH P.M., NATRONA COUNTY, WYOMING, BEING MORE PARTICULARLY DESCRIBED AS FOLLOWS:

COMMENCING AT THE NE¼ CORNER COMMON TO SAID SECTIONS 32 AND 33, MONUMENTED BY A BRASS CAP AND BEING THE POINT OF BEGINNING;

- THENCE S01°19'42"E, ALONG THE LINE COMMON TO SECTIONS 32 AND 33, A DISTANCE OF 189.28 FEET TO A POINT, MONUMENTED BY A BRASS CAP;
- THENCE S73°03'04"E, A DISTANCE OF 1094.11 FEET TO A POINT, MONUMENTED BY A BRASS CAP;
- THENCE S69°36'44"E, A DISTANCE OF 295.39 FEET TO A POINT, MONUMENTED BY A BRASS CAP;
- THENCE S13°48'45"W, A DISTANCE OF 426.44 FEET TO A POINT, MONUMENTED BY A BRASS CAP;
- THENCE S82°31'45"E, A DISTANCE OF 912.59 FEET TO A POINT, MONUMENTED BY A BRASS CAP;
- THENCE S12°33'35"W, A DISTANCE OF 586.51 FEET TO A POINT OF CURVATURE, MONUMENTED BY A BRASS CAP;
- THENCE ALONG A CURVE TO THE RIGHT HAVING RADIUS OF 1100.00 FEET, THROUGH A CENTRAL ANGLE OF 29°07'47", DISTANCE OF 559.25 FEET, WITH A CHORD BEARING OF S27°07'29"W, A DISTANCE OF 553.25 FEET TO THE END OF CURVE, MONUMENTED BY A BRASS CAP;
- THENCE S41°41'22"W, A DISTANCE OF 860.78 FEET TO A POINT, MONUMENTED BY A BRASS CAP;
- THENCE N50°26'08"W, A DISTANCE OF 526.11 FEET TO A POINT, MONUMENTED BY A BRASS CAP;
- THENCE N86°01'42"W, A DISTANCE OF 155.67 FEET TO A POINT, MONUMENTED BY A BRASS CAP;
- THENCE N52°18'33"W, A DISTANCE OF 139.05 FEET TO A POINT, MONUMENTED BY A BRASS CAP;
- THENCE S57°45'09"W, A DISTANCE OF 467.87 FEET TO A POINT, MONUMENTED BY A BRASS CAP;
- THENCE N18°40'19"W, A DISTANCE OF 391.65 FEET TO A POINT, MONUMENTED BY A BRASS CAP;
- THENCE N31°50'34"W, A DISTANCE OF 432.22 FEET TO A POINT, MONUMENTED BY A BRASS CAP;
- THENCE IN A SOUTHEAST DIRECTION ALONG A CURVE TO THE RIGHT HAVING A RADIUS OF 1560.00 FEET, THROUGH A CENTRAL ANGLE OF 10°10'38", A DISTANCE OF 277.10 FEET, WITH A CHORD BEARING OF S68°17'17"W, A DISTANCE OF 276.73 FEET TO THE END OF CURVE, MONUMENTED BY A BRASS CAP;
- THENCE S43°36'44"W, A DISTANCE OF 249.65 FEET TO AN ANGLE POINT, MONUMENTED BY A BRASS CAP;
- THENCE S06°47'42"W, A DISTANCE OF 311.14 FEET TO THE NORTHEAST CORNER OF THE NORTH PLATTE INDUSTRIAL PARK, MONUMENTED BY A BRASS CAP;
- THENCE N83°14'27"W, A DISTANCE OF 139.88 FEET TO A POINT LOCATED ON THE NORTH LINE OF WILKINS WAY AND BEING THE SOUTHEAST CORNER OF AN UNPLATTED PARCEL RECORDED AS INSTRUMENT NO. 990378, MONUMENTED BY A WYDOT MONUMENT;
- THENCE N06°39'54"E, ALONG THE EAST LINE OF SAID UNPLATTED PARCEL, A DISTANCE OF 318.78 FEET, TO THE NORTHEAST CORNER OF SAID UNPLATTED PARCEL, MONUMENTED BY A WYDOT MONUMENT;
- THENCE N84°43'38"W, ALONG THE NORTH LINE OF SAID UNPLATTED PARCEL, A DISTANCE OF 65.84 FEET TO AN ANGLE POINT, MONUMENTED BY A WYDOT MONUMENT;
- THENCE S76°41'51"W, ALONG THE NORTH LINE OF SAID UNPLATTED PARCEL, A DISTANCE OF 153.98 FEET TO A POINT OF CURVATURE, MONUMENTED BY A WYDOT MONUMENT;
- THENCE ALONG A CURVE TO THE LEFT HAVING A RADIUS OF 1759.86 FEET, THROUGH A CENTRAL ANGLE OF 17°52'59", A DISTANCE OF 549.29 FEET, WITH A CHORD BEARING OF S67°58'56"W, A DISTANCE OF 547.06 FEET TO THE END OF CURVE, MONUMENTED BY A WYDOT MONUMENT;
- THENCE S59°00'29"W, A DISTANCE OF 156.92 FEET TO A POINT, MONUMENTED BY A WYDOT MONUMENT;
- THENCE N31°00'11"W, A DISTANCE OF 300.73 FEET TO A POINT, MONUMENTED BY A WYDOT MONUMENT;
- THENCE N71°19'59"W, A DISTANCE OF 124.17 FEET TO A POINT, LOCATED ON THE EAST LINE OF INTERSTATE 25, MONUMENTED BY A WYDOT MONUMENT;
- THENCE IN A NORTHWEST DIRECTION ALONG THE EAST LINE OF INTERSTATE 25, AND A CURVE TO THE RIGHT HAVING A RADIUS OF 4433.66 FEET, THROUGH A CENTRAL ANGLE OF 14°30'20", A DISTANCE OF 1122.47 FEET, WITH A CHORD BEARING OF N01°10'09"W, A DISTANCE OF 1119.47 FEET TO THE END OF CURVE, MONUMENTED BY A WYDOT MONUMENT;
- THENCE N06°04'30"E, ALONG THE EAST LINE OF INTERSTATE 25, A DISTANCE OF 414.13 FEET, TO AN ANGLE POINT, MONUMENTED BY A WYDOT MONUMENT;
- THENCE N06°03'39"E, ALONG THE EAST LINE OF INTERSTATE 25, A DISTANCE OF 636.32 FEET TO THE NORTHWEST CORNER OF THE PARCEL BEING DESCRIBED, LOCATED ON THE NORTH LINE OF THE S½W½ OF SAID SECTION 32, MONUMENTED BY A WYDOT MONUMENT;
- THENCE N88°34'12"E, ALONG THE NORTH LINE OF THE S½W½ OF SAID SECTION 32, A DISTANCE OF 125.98 FEET TO AN ANGLE POINT, MONUMENTED BY A WYDOT MONUMENT
- THENCE N88°37'16"E, ALONG THE NORTH LINE OF THE S½W½ OF SAID SECTION 32, A DISTANCE OF 402.29 FEET TO THE NE¼ CORNER OF SAID SECTION 32, MONUMENTED BY A BRASS CAP;
- THENCE N88°33'47"E, ALONG THE NORTH LINE OF THE S½W½ OF SAID SECTION 32, A DISTANCE OF 1323.55 FEET TO THE POINT OF BEGINNING.

THE ABOVE DESCRIBED TRACT OF LAND CONTAINS 185.10 ACRES, MORE OR LESS AND IS SUBJECT TO ANY RIGHTS-OF-WAY AND/OR EASEMENTS, RESERVATIONS AND ENCUMBRANCES WHICH HAVE BEEN LEGALLY ACQUIRED.

THE TRACT OF LAND, AS IT APPEARS ON THIS PLAT, IS DEDICATED WITH THE FREE CONSENT AND IN ACCORDANCE WITH THE DESIRES OF THE UNDERSIGNED OWNER AND PROPRIETOR. THE NAME OF THE SUBDIVISION SHALL BE "NORTH PLATTE RIVER PARK NO. 2" AND THE OWNER HEREBY GRANTS TO THE PUBLIC AND PRIVATE UTILITY COMPANIES AN EASEMENT AND LICENSE TO LOCATE, CONSTRUCT, USE AND MAINTAIN CONDUITS, LINES, WIRES AND PIPES, ANY OR ALL OF THEM, UNDER AND ALONG THE STRIPS OF LAND MARKED "UTILITY EASEMENT" AS SHOWN ON THIS PLAT. ALL ROADS AND STREETS AS SHOWN HEREON ARE HEREBY DEDICATED TO THE USE OF THE PUBLIC.

A VACATION AND REPLAT OF
A PORTION OF TRACT 4
NORTH PLATTE RIVER PARK SUBDIVISION
AS
NORTH PLATTE RIVER PARK NO. 2

AN ADDITION TO THE CITY OF CASPER, WYOMING
BEING A PORTION OF THE S½E½ AND THE N½E½ OF
SECTION 32, AND THE S½W½ AND THE N½W½ OF
SECTION 33, T.34N., R.79W., 6TH P.M.
NATRONA COUNTY, WYOMING
OCTOBER, 2021

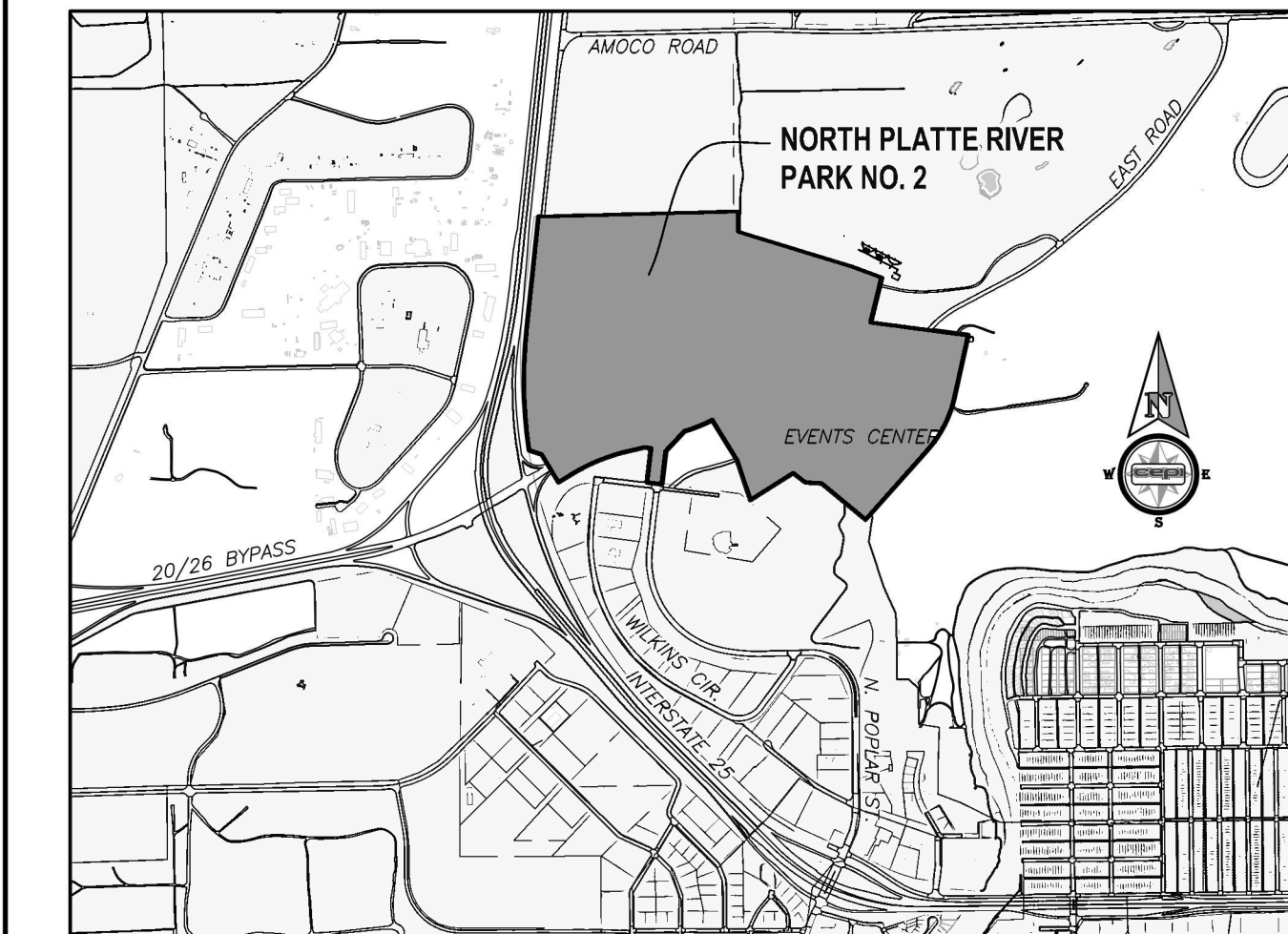
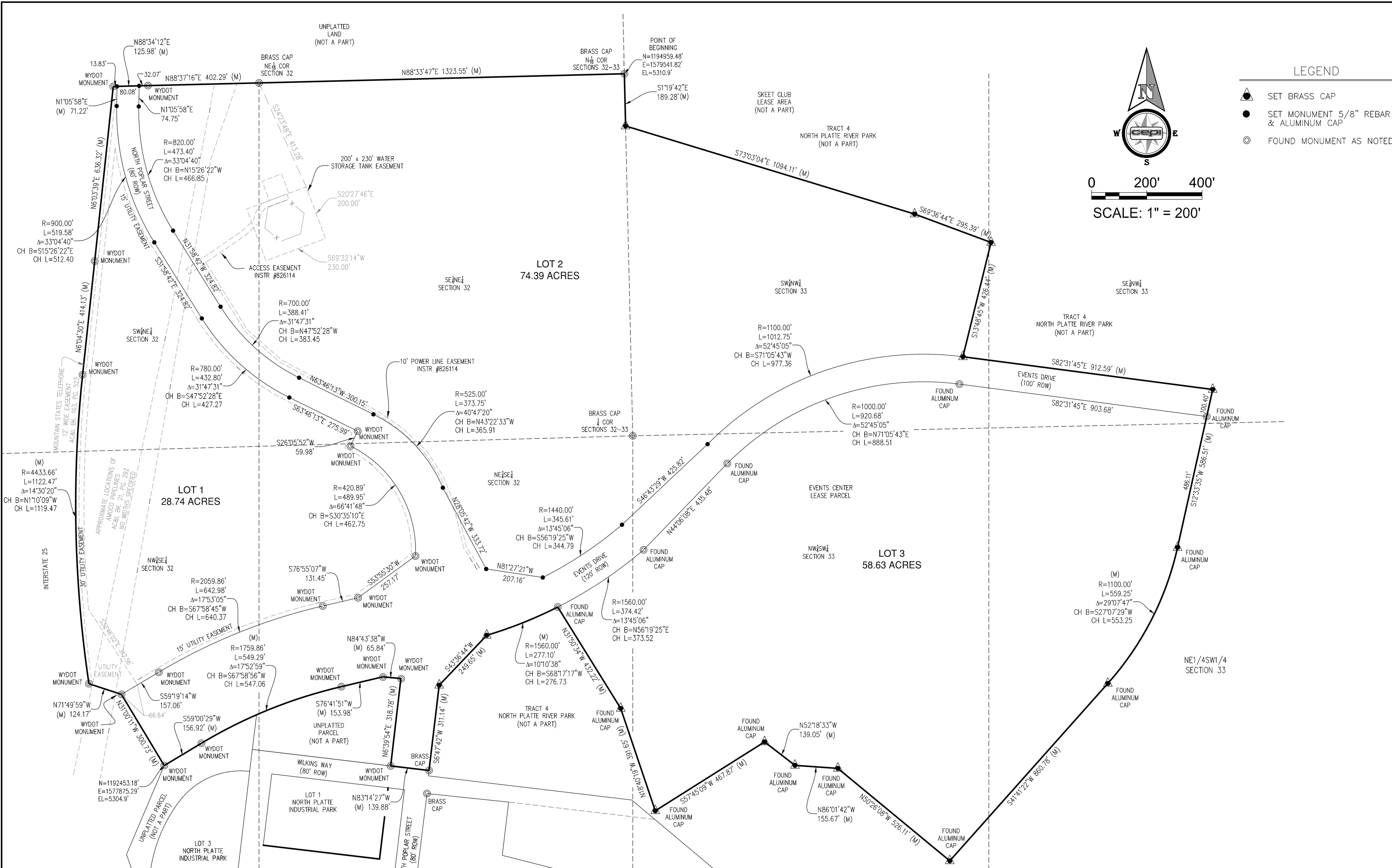

NOTES

- ERROR OF CLOSURE EXCEEDS 1:517,423.
- BASIS OF BEARINGS IS THE WYOMING STATE PLANE COORDINATE SYSTEM, EAST CENTRAL ZONE, NAD 1983/2011.
- THE CONVERGENCE ANGLE AT THE POINT OF BEGINNING IS 00°40'41.88", AND THE COMBINED FACTOR IS 0.99976532.
- ALL DISTANCES ARE GROUND.
- ELEVATIONS SHOWN HEREON ARE BASED ON NAVD 88 DATUM AND ARE NOT MEANT TO BE USED AS BENCHMARKS.

CERTIFICATE OF SURVEYOR

STATE OF WYOMING }
COUNTY OF NATRONA }SS

I, WILLIAM R. FEHRINCER, A REGISTERED PROFESSIONAL LAND SURVEYOR, LICENSE NO. 5528, DO HEREBY CERTIFY THAT THIS PLAT WAS MADE FROM NOTES TAKEN DURING AN ACTUAL SURVEY MADE UNDER MY DIRECT SUPERVISION IN SEPTEMBER, 2021 AND THAT THIS PLAT, TO THE BEST OF MY KNOWLEDGE AND BELIEF, CORRECTLY AND ACCURATELY REPRESENTS SAID SURVEY. ALL DIMENSIONS ARE EXPRESSED IN FEET AND DECIMALS THEREOF. COURSES ARE REFERRED TO THE WYOMING STATE PLANE COORDINATE SYSTEM, EAST CENTRAL ZONE, NAD 1983/2011, CITY OF CASPER GIS SYSTEM. ALL BEING TRUE AND CORRECT TO THE BEST OF MY KNOWLEDGE AND BELIEF.

THE FOREGOING INSTRUMENT WAS ACKNOWLEDGED BEFORE ME BY WILLIAM R. FEHRINCER
THIS _____ DAY OF _____, 2021.

WITNESS MY HAND AND OFFICIAL SEAL.
MY COMMISSION EXPIRES _____

NOTARY PUBLIC

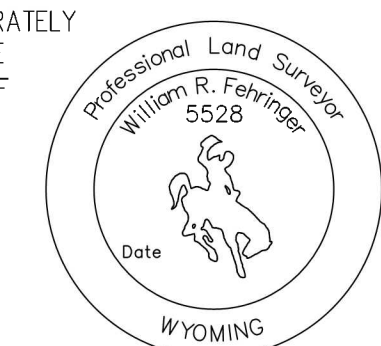

APPROVALS

APPROVED BY THE CITY OF CASPER PLANNING AND ZONING COMMISSION OF CASPER, WYOMING
THIS _____ DAY OF _____, 2021.

ATTEST: _____ SECRETARY _____ CHAIRMAN

APPROVED BY THE CITY COUNCIL OF CASPER, WYOMING BY ORDINANCE NO. _____, DULY PASSED,
ADOPTED AND APPROVED THIS _____ DAY OF _____, 2021.

ATTEST: _____ CITY CLERK _____ MAYOR

INSPECTED AND APPROVED THIS _____ DAY OF _____, 2021.

INSPECTED AND APPROVED THIS _____ DAY OF _____, 2021.

_____ CITY SURVEYOR

CITY OF CASPER
200 NORTH DAVID
CASPER, WYOMING 82601
STEVEN K. FREEL - MAYOR

THE FOREGOING INSTRUMENT WAS ACKNOWLEDGED BEFORE ME BY STEVEN K. FREEL, MAYOR
OF THE CITY OF CASPER, THIS _____ DAY OF _____, 2021.

WITNESS MY HAND AND OFFICIAL SEAL.
MY COMMISSION EXPIRES _____

NOTARY PUBLIC



VICINITY MAP
NO SCALE

September 21, 2022

MEMO TO: J. Carter Napier, City Manager *JCN*

FROM: Liz Becher, Community Development Director *lb*
Beth Address, MPO Supervisor
Renee Hardy, MPO Technician

SUBJECT: Evansville Texas Street Extension Study Professional Services Contract in the amount of \$39,946.82

Meeting Type & Date:

Regular Council Meeting, October 18, 2022.

Action Type:

Resolution

Recommendation:

That Council, by resolution, approve the City of Casper's Contract for Professional Services with KLJ Engineering, LLC. for Evansville Texas Street Extension Study in an amount not to exceed \$39,946.82.

The City is obligated to approve this contract as the MPO's fiscal agent.

Summary:

The Casper Area Metropolitan Planning Organization (MPO) is composed of the City of Casper, the Towns of Bar Nunn and Evansville, the City of Mills, and Natrona County. The MPO along with the member jurisdictions guided by the Long Range Transportation Plan identifies projects and programs they wish to complete each federal year. These programs and projects are presented by the MPO each year in the Unified Planning Work Program (UPWP) which is voted on and approved by representatives from all the MPO member jurisdictions on both the Technical and Policy Committees. The Fiscal Year 2023 UPWP included \$40,000.00 of matched federal funding for Evansville Texas Street Extension Study.

The Evansville Texas Street Extension Study will examine the impacts of extending Texas Street from Miracle Drive to the East Yellowstone Highway (US 20/26), in order to improve traffic flow at the E Lathrop Road and Curtis Street intersection. The study will also examine how the proposed extension would influence all forms of transportation in the larger multi-modal network. The study will provide decision-makers and the public with recommendations supported by visualizations and measurable benefits to all users.

This study meets all the goals set forth in the 2020 update of the Long Range Transportation Plan: *Connecting Crossroads* including increasing transportation options for all modes, improving safety and health for all residents, enhancing the region's distinct character, promoting affordable

and easy mobility solutions, and supporting the region’s diversifying economy. The study was recommended by the 2021 Lathrop Road Traffic Study.

The Casper Area MPO released a Request for Proposals (RFP) on August 5, 2022. Although nine (9) consultants requested the full RFP, only one (1) consulting firm responded with a proposal by the September 2, 2022, deadline. Staff from the Town of Evansville, WYDOT, and the MPO reviewed the proposal, and on September 20, 2022, selected KLJ Engineering, LLC. based on the quality of the initial proposal, qualifications of proposed staff, interviews, reference checks, and understanding of the project. The MPO expects the proposed project to be completed by March 30, 2023.

Financial Considerations:

The proposed contract shall not exceed \$39,946.82. Funding for this project comes from the Casper Area MPO, including federal monies and contributions from member agencies. Each member agency pays a portion of the budget for all Casper Area MPO projects regardless of whether that project is in their jurisdiction. All Casper Area MPO jurisdictional members pay their share of the total UPWP local match for each year in October. Funding for the project breaks down as follows; federal funds account for 90.49% of the total project budget. The remaining 9.51% of the total budget is split, based upon population, among the separate jurisdictional member agencies of the Casper Area MPO. Those amounts break down as follows:

Federal Funds	90.49%	\$36,147.88
Local Match	9.51%	\$3,798.94
City of Casper	73.31%	\$2,786.62
Natrona County	15.80%	\$600.23
City of Mills	4.59%	\$174.37
Town of Evansville	3.37%	\$128.02
Town of Bar Nunn	2.93%	\$111.31
	Total	\$39,946.82

The Casper Area MPO Policy Committee approved the funding of \$40,000.00 of MPO Programs and Projects funds from the federal Consolidated Planning Grant for the total project on June 16, 2022.

Oversight/Project Responsibility:

Beth Andress, MPO Supervisor

Attachments:

Resolution, Contract for Professional Services

CONTRACT FOR PROFESSIONAL SERVICES

PART I - AGREEMENT

This Contract for Professional Services (“Contract or Agreement”) is entered into on this _____ day of _____, 2022, by and between the following parties:

1. The City of Casper, Wyoming, a Wyoming municipal corporation, 200 North David Street, Casper, Wyoming 82601 (“City” or “Owner”).

2. KLJ Engineering LLC, 4585 Coleman Street, Bismarck, North Dakota 58503-0431 (“Consultant”)

Throughout this document, the City and the Consultant may be collectively referred to as the “parties.”

RECITALS

A. The City needs professional planning services for the Evansville Texas Street Extension Study, hereinafter referred to as the “Project”.

B. The City desires to retain the Consultant to render certain technical and professional services to complete the necessary work for the Project.

C. The Consultant represents that it is ready, willing, and able to provide the professional services to the City as required by this Contract.

D. The City desires to retain the Consultant for such services.

NOW, THEREFORE, in consideration of the covenants and conditions set forth herein to be performed, the parties agree as follows:

1. SCOPE OF SERVICES.

The Consultant shall perform the following services in connection with and respecting the project, Evansville Texas Street Extension Study, and as described on Exhibit A (Scope of Services), attached and made a part of this Contract.

A. Subject to the Consultant Limitations of Part II, paragraph YY of this Agreement, the Consultant agrees to perform, directly or by association with such other consultants or contractors as it may deem necessary to further the interest of the City, the services and tasks as set forth in Exhibit “A” (Scope of Services), attached hereto and made a part of this Contract.

- B. Notwithstanding anything to the contrary herein, Consultant will use that degree of care and skill ordinarily exercised by members of same profession performing the same or similar services under similar conditions in similar localities (“Standard of Care”) and in accordance with the Standard of Care, will identify, reasonably interpret and respond to all applicable provisions of federal, state and local laws. No other warranties, express or implied, are made or intended.

2. TIME OF PERFORMANCE:

A. The Consultant agrees to begin work on the Project following receipt of this fully executed Agreement from the City. Consultant shall follow timeline/estimated completion as set forth in Exhibit A.

B. The Scope of Services listed in Paragraph 1 shall be completed on or before March 30, 2023.

3. COMPENSATION:

A. In consideration of the performance of services rendered under this Contract, the Consultant shall be compensated for time and materials in accordance with this Contract, and as outlined on the fee schedule attached hereto and labeled as Exhibit “G” and by reference made part of this Contract, a cost-not-to-exceed Thirty-Nine Thousand Nine Hundred Forty-Six Dollars and Eighty-Two Cents (\$39,946.82). Consultant's hourly rates used as a basis for payment mean salaries and wages (basic and incentive) paid to all Consultant's personnel while engaged directly on the Project (see hourly charge matrix – Exhibit G), including, but not limited to, engineers, architects, surveyors, designers, drafters, specification writers, estimators, other technical and business personnel.

B. Exhibit G is in accordance and compliance with the Code of Federal Regulations (CFR), Title 48, Part 31, and the rates shown shall establish and include full compensation for all payroll costs, general overhead, materials, equipment, travel, meals, lodging and profit, and shall constitute full payment for services performed under this Agreement and for all expenditures incurred or made, except as otherwise expressly provided for herein.

C. The fixed fee profit of Four Thousand One Hundred Five Dollars and Fifty-Seven Cents (\$4,105.57) shall be paid as a percentage (12%) of the Adjusted Direct labor billed on each approved invoice, with any remainder to be paid upon final Agreement completion.

D. Partial payment shall be made by the City on the basis of the progress of the work and per invoices submitted and approved for the same. Itemized invoices shall show a breakdown of the total charge by man hours (or other charge units) multiplied by the established Agreement rate. These extensions shall be broken out by phases of work. All direct expenses shall be broken out by unit cost. A progress report of work performed during the billing period shall be

included with the payment request and attached to the invoice. All correspondence and invoicing shall include project number, project name, Agreement number and billing period. If subconsultants are utilized, a copy of their monthly billing and a brief description of the work performed shall be attached to the Consultant's invoice. Failure to comply with the City's billing policy may result in a delay of payment.

4. METHOD OF PAYMENT:

- A. Payment will be made following completion of the terms set forth herein and receipt of an itemized invoice, certified under penalty of perjury, from the Consultant for services rendered in conformance with the Agreement, and following approval by the Casper City Council. The invoice for payment must specify the correct amount due; that the Consultant has performed the services rendered under this Agreement, in conformance with the Agreement, and that it is entitled to receive the amount requested under the terms of the Agreement.
- B. Invoices shall be submitted on a monthly basis for services provided in the prior month. Invoices shall be submitted by the fourteenth day of the following month for services provided in the previous month. The City will retain five percent (5%) of total Project cost, or One Thousand Nine Hundred Ninety Seven Dollars and Thirty Four Cents (\$1,997.34), until the Community Development Director provides written notice of final acceptance of the Project.
- C. If amounts owed by the Consultant to the City for any goods, services, licenses, permits or any other items or purpose remain unpaid beyond the City's general credit policy, those amounts may be deducted from the payment being made by the City to the Consultant pursuant to this Agreement.

5. TERMS AND CONDITIONS:

This Agreement is subject to and incorporates the provisions attached hereto as PART II - GENERAL TERMS AND CONDITIONS and PART III FEDERAL CONTRACTURAL PROVISIONS. The following additional Exhibits, as attached hereto are incorporated herein at this point as if fully set forth as part of this Contract:

Exhibit A: Scope of Services

Exhibit B: MPO Policy Committee Approval

Exhibit C: Notice to Consultant Compliance with Title VI of the Civil Rights Act of 1964 for Federal Aid Projects

Exhibit D: Certification of Consultant

Exhibit E: Certification of AGENT

Exhibit F: Certification of Suspension or Debarment

Exhibit G: Fee Schedule

6. EXTENT OF CONTRACT:

This Contract represents the entire and integrated Contract between the City and the Consultant, and supersedes all prior negotiations, representations, or agreements, either written or oral. This Contract may be amended only by written instrument signed by both the City's and the Consultant's authorized representatives.

The City and the Consultant each individually represent that they have the requisite authority to execute this Contract and perform the services described in this Contract.

IN WITNESS WHEREOF, the undersigned duly authorized representatives of the parties have executed this Contract as of the day and year above.

*** The rest of this page is intentionally left blank ***

APPROVED AS TO FORM:

Valerie Tremel

ATTEST:

CITY OF CASPER, WYOMING
A Municipal Corporation, as AGENT:

Fleur Tremel
City Clerk

Ray Pacheco
Mayor

WITNESS:

KLJ Engineering LLC, as Consultant:

By: Erika Lorenz

By: Mark Anderson

Printed name: Erika Lorenz

Printed name: Mark Anderson

Title: Contract Administrator

Title: SVP

CONTRACT FOR PROFESSIONAL SERVICES
PART II - GENERAL TERMS AND CONDITIONS

- A. **Assumption of Risk.** The Consultant shall assume the risk of any loss of state or federal funding, either administrative or program dollars, due to the Consultant's failure to comply with state or federal requirements. Owner shall notify the Consultant of any state or federal determination of noncompliance.
- B. **Conflict of Interest.** Per 2 CFR 200.112, the Consultant must disclose in writing any potential conflict of interest to Owner including financial or other personal interests.
- C. **Environmental Policy Acts.** The Consultant agrees all activities under this Agreement will comply with the Clean Air Act, the Clean Water Act, the National Environmental Policy Act, and other related provisions of federal environmental protection laws, rules or regulations.
- D. **Human Trafficking.** As required by 22 U.S.C. § 7104(g) and 2 CFR Part 175, this Agreement may be terminated without penalty if a private entity that receives funds under this Agreement:
- (i) Engages in severe forms of trafficking in persons during the period of time that the award is in effect;
 - (ii) Procures a commercial sex act during the period of time that the award is in effect;
or
 - (iii) Uses forced labor in the performance of the award or subawards under the award.
- E. **Kickbacks.** The Consultant certifies and warrants that no gratuities, kickbacks, or contingency fees were paid in connection with this Agreement, nor were any fees, commissions, gifts, or other considerations made contingent upon the award of this Agreement. If Consultant breaches or violates this warranty, the Owner may, at its discretion, terminate this Agreement without liability to the Owner, or deduct from the agreed upon price or consideration, or otherwise recover, the full amount of any gratuity, kickback, commission, percentage, brokerage, or contingency fee.
- F. **Limitations on Lobbying Activities.** By signing this Agreement, the Consultant certifies and agrees that, in accordance with P.L. 101-121, payments made from a federal grant shall not be utilized by the Consultant or its subcontractors in connection with lobbying member(s) of Congress, or any federal agency in connection with the award of a federal grant, contract, cooperative agreement, or loan.

- G. **Mandatory Disclosures.** Per 2 CFR 200.113, the Consultant must disclose, in a timely manner, in writing to the Owner, all violations of Federal criminal law involving fraud, bribery, or gratuity violations potentially affecting this award. Failure to make required disclosures can result in remedies for noncompliance including suspension or debarment.
- H. **Monitoring Activities.** The Owner shall have the right to monitor all activities related to this Agreement that are performed by the Consultant or its subcontractors. This shall include, but not be limited to, the right to make site inspections at any time and with reasonable notice; to bring experts and consultants on site to examine or evaluate completed work or work in progress; to examine the books, ledgers, documents, papers, and records pertinent to this Agreement; and, to observe personnel in every phase of performance of the related work.
- I. **Nondiscrimination.** The Consultant shall comply with the Civil Rights Act of 1964, the Wyoming Fair Employment Practices Act (Wyo. Stat. § 27-9-105, *et seq.*), the Americans with Disabilities Act (ADA), 42 U.S.C. § 12101, *et seq.*, and the Age Discrimination Act of 1975 and any properly promulgated rules and regulations thereto and shall not discriminate against any individual on the grounds of age, sex, color, race, religion, national origin, or disability in connection with the performance under this Agreement.
- J. **No Finder's Fees.** No finder's fee, employment agency fee, or other such fee related to the procurement of this Agreement, shall be paid by either party.
- K. **Publicity.** Any publicity given to the program or services provided herein, including, but not limited to, notices, information, pamphlets, press releases, research, reports, signs, and similar public notices prepared by or for the Consultant and related to the services and work to be performed under this Agreement, shall identify the City of Casper, WYDOT, The Federal Highway Administration and/or the Federal Transit Administration as the sponsoring agency and shall not be released without prior written approval of the Owner.
- L. **Suspension and Debarment.** By signing this Agreement, the Consultant certifies that neither it nor its principals/agents are presently debarred, suspended, proposed for debarment, declared ineligible, or voluntarily excluded from participation in this transaction or from receiving federal financial or nonfinancial assistance, nor are any of the participants involved in the execution of this Agreement suspended, debarred, or voluntarily excluded by any federal department or agency in accordance with Executive Order 12549 (Debarment and Suspension), 44 CFR Part 17, or 2 CFR Part 180, or are on the debarred, or otherwise ineligible, vendors lists maintained by the federal government. Further, the Consultant agrees to notify the Owner by certified mail should

it or any of its principals/agents become ineligible for payment, debarred, suspended, or voluntarily excluded from receiving federal funds during the term of this Agreement.

- M. **Administration of Federal Funds.** The Consultant agrees its use of the funds awarded herein is subject to the Uniform Administrative Requirements of 2 CFR Part 200, *et seq.*; any additional requirements set forth by the federal funding agency; all applicable regulations published in the Code of Federal Regulations; and other program guidance as provided to it by the Owner.
- N. **Copyright License and Patent Rights.** The Consultant acknowledges that federal grantor, the State of Wyoming, and the Owner reserve a royalty-free, nonexclusive, unlimited, and irrevocable license to reproduce, publish, or otherwise use, and to authorize others to use, for federal and state government purposes: (1) the copyright in any work developed under this Agreement; and (2) any rights of copyright to which the Consultant purchases ownership using funds awarded under this Agreement. The Consultant must consult with the Owner regarding any patent rights that arise from, or are purchased with, funds awarded under this Agreement.
- O. **Federal Audit Requirements.** The Consultant agrees that if it expends an aggregate amount of seven hundred fifty thousand dollars (\$750,000.00) or more in federal funds during its fiscal year, it must undergo an organization-wide financial and compliance single audit. The Consultant agrees to comply with the audit requirements of the U.S. General Accounting Office Government Auditing Standards and Audit Requirements of 2 CFR Part 200, Subpart F. If findings are made which cover any part of this Grant, the Consultant shall provide one (1) copy of the audit report to the Owner and require the release of the audit report by its auditor be held until adjusting entries are disclosed and made to the Owner's records.
- P. **Non-Supplanting Certification.** The Consultant hereby affirms that federal grant funds shall be used to supplement existing funds, and shall not replace (supplant) funds that have been appropriated for the same purpose. The Consultant should be able to document that any reduction in non-federal resources occurred for reasons other than the receipt or expected receipt of federal funds under this Agreement.
- Q. **Program Income.** The Consultant shall not deposit grant funds in an interest bearing account without prior approval of the Owner. Any income attributable to the grant funds distributed under this Agreement must be used to increase the scope of the program or returned to Owner.
- R. **Amendments.** Any changes, modifications, revisions, or amendments to this Agreement which are mutually agreed upon by the parties to this Agreement shall be incorporated by written instrument, executed and signed by all parties to this Agreement.

- S. **Applicable Law, Rules of Construction, and Venue.** The construction, interpretation, and enforcement of this Agreement shall be governed by the laws of the State of Wyoming, without regard to conflicts of law principles. The terms “hereof,” “hereunder,” “herein,” and words of similar import, are intended to refer to this Agreement as a whole and not to any particular provision or part. The Courts of the State of Wyoming shall have jurisdiction over this Agreement and the parties. The venue shall be the First Judicial District, Laramie County, Wyoming if the State of Wyoming is a named or joined party, otherwise venue shall be 7th Judicial District, Natrona County, Wyoming.
- T. **Assignment/Agreement Not Used as Collateral.** Neither party shall assign or otherwise transfer any of the rights or delegate any of the duties set out in this Agreement without the prior written consent of the other party. The Consultant shall not use this Agreement, or any portion thereof, for collateral for any financial obligation without the prior written permission of the Owner.
- U. **Audit/Access to Records.** The Owner and its representatives shall have access to any books, documents, papers, electronic data, and records of the Consultant which are pertinent to this Agreement. The Consultant shall immediately, upon receiving written instruction from the Owner, provide to any independent auditor or accountant all books, documents, papers, electronic data, and records of the Consultant which are pertinent to this Agreement. The Consultant shall cooperate fully with any such independent auditor or accountant during the entire course of any audit authorized by the Owner.
- V. **Availability of Funds.** Each payment obligation of the Owner is conditioned upon the availability of government funds which are appropriated or allocated for the payment of this obligation and which may be limited for any reason including, but not limited to, congressional, legislative, gubernatorial, or administrative action. If funds are not allocated and available for continued performance of the Agreement, the Agreement may be terminated by the Owner at the end of the period for which the funds are available. The Owner shall notify the Consultant at the earliest possible time of the services which will or may be affected by a shortage of funds. No penalty shall accrue to the Owner in the event this provision is exercised, and the Owner shall not be obligated or liable for any future payments due or for any damages as a result of termination under this section.
- W. **Award of Related Agreements.** The Owner may award supplemental or successor Agreements for work related to this Agreement. The Consultant shall cooperate fully with other contractors and the Owner in all such cases.
- X. **Certificate of Good Standing.** The Consultant shall provide to the Owner a Certificate of Good Standing verifying compliance with all applicable unemployment insurance and

workers' compensation programs before and during performance of work under this Agreement, if applicable.

- Y. **Compliance with Laws.** The Consultant shall keep informed of and comply with all applicable federal, state, and local laws and regulations, and all federal grant requirements and executive orders in the performance of this Agreement.
- Z. **Confidentiality of Information.** All documents, data compilations, reports, computer programs, photographs, data, and other work provided to or produced by the Consultant in the performance of this Agreement shall be kept confidential by the Consultant unless written permission is granted by the Owner for its release. If and when the Consultant receives a request for information subject to this Agreement, the Consultant shall notify the Owner within ten (10) days of such request and shall not release such information to a third party unless directed to do so by the Owner, or a court of competent jurisdiction.
- AA. **Entirety of Agreement.** This Agreement, consisting of twenty-five (25) pages; Exhibit A, Scope of Services consisting of two (2) pages; Exhibit B, MPO Policy Committee Approval, consisting of one (1) page; Exhibit C, Notice to Consultant – Compliance with Title VI of the Civil Rights Act of 1964 for Federal-Aid Contracts, consisting of two (2) pages; Exhibit D, Certification of Contractor, consisting of one (1) page; Exhibit E, Certificate of Agent, consisting of one (1) page; Exhibit F, Certification of Suspension or Debarment, consisting of one (1) page; and Exhibit G, Fee Schedule, consisting of one (1) page represents the entire and integrated Agreement between the parties and supersedes all prior negotiations, representations, and agreements, whether written or oral. In the event of a conflict or inconsistency between the language of this Agreement and the language of any attachment or document incorporated by reference, the language of this Agreement shall control.
- BB. **Ethics.** The Consultant shall keep informed of and comply with the Wyoming Ethics and Disclosure Act (Wyo. Stat. § 9-13-101, *et seq.*) and any and all ethical standards governing the Consultant's profession.
- CC. **Extensions.** Nothing in this Agreement shall be interpreted or deemed to create an expectation that this Agreement will be extended beyond the term described herein. Any extension of this Agreement shall be initiated by the Owner and shall be accomplished through a written amendment between the parties entered into before the expiration of the original Agreement or any valid amendment thereto, and shall be effective only after it is reduced to writing and executed by all parties to the Agreement.
- DD. **Force Majeure.** Neither party shall be liable for failure to perform under this Agreement if such failure to perform arises out of causes beyond the control and without the fault or negligence of the nonperforming party. Such causes may include, but are not limited to,

acts of God or the public enemy, fires, floods, epidemics, quarantine restrictions, freight embargoes, and unusually severe weather. This provision shall become effective only if the party failing to perform immediately notifies the other party of the extent and nature of the problem, limits delay in performance to that required by the event, and takes all reasonable steps to minimize delays.

- EE. **Indemnification.** The Consultant shall release, indemnify, and hold harmless the Owner and the State of Wyoming, and their officers, agents, employees, successors, and assignees from any and all claims, lawsuits, losses, and liability arising out of the Consultant's failure to perform any of the Consultant's duties and obligations hereunder or in connection with the negligent performance of the Consultant's duties or obligations, including, but not limited to, any claims, lawsuits, losses, or liability arising out of the Consultant's negligence or other tortious conduct.
- FF. **Independent Contractor.** The Consultant shall function as an independent contractor for the purposes of this Agreement and shall not be considered an employee of the Owner and the State of Wyoming for any purpose. Consistent with the express terms of this Agreement, the Consultant shall be free from control or direction over the details of the performance of services under this Agreement. The Consultant shall assume sole responsibility for any debts or liabilities that may be incurred by the Consultant in fulfilling the terms of this Agreement and shall be solely responsible for the payment of all federal, state, and local taxes which may accrue because of this Agreement. Nothing in this Agreement shall be interpreted as authorizing the Consultant or its agents or employees to act as an agent or representative for or on behalf of the Owner and the State of Wyoming or to incur any obligation of any kind on the behalf of the Owner and the State of Wyoming. The Consultant agrees that no health/hospitalization benefits, workers' compensation, unemployment insurance, or similar benefits available to Owners or State of Wyoming employees will inure to the benefit of the Consultant or the Consultant's agents or employees as a result of this Agreement.
- GG. **Notices.** All notices arising out of, or from, the provisions of this Agreement shall be in writing either by regular mail or delivery in person at the addresses provided under this Agreement.
- HH. **Notice of Sale or Transfer.** The Consultant shall provide the Owner with notice of any sale, transfer, merger, or consolidation of the assets of the Consultant. Such notice shall be provided in accordance with the notices provision of this Agreement and, when possible and lawful, in advance of the transaction. If the Owner determines that the sale, transfer, merger, or consolidation is not consistent with the continued satisfactory performance of the Consultant's obligations under this Agreement, then the Owner may, at its discretion, terminate or renegotiate the Agreement.

- II. **Ownership and Destruction of Documents/Information.** The Owner owns all documents, data compilations, reports, computer programs, photographs, data, and other work provided to or produced by the Consultant in the performance of this Agreement. Upon termination of services, for any reason, the Consultant agrees to return all such original and derivative information/documents to the Owner in a useable format. In the case of electronic transmission, such transmission shall be secured. The return of information by any other means shall be by a parcel service that utilizes tracking numbers. Upon the Owner's verified receipt of such information, the Consultant agrees to physically and electronically destroy any residual Owner-owned data, regardless of format, and any other storage media or areas containing such information. The Consultant agrees to provide written notice to the Owner confirming the destruction of any such residual Owner-owned data.
- JJ. **Patent or Copyright Protection.** The Consultant recognizes that certain proprietary matters or techniques may be subject to patent, trademark, copyright, license, or other similar restrictions, and warrants that no work performed by the Consultant or its subcontractors will violate any such restriction. The Consultant shall defend and indemnify the Owner for any violation or alleged violation of such patent, trademark, copyright, license, or other restrictions.
- KK. Reserved for future use.
- LL. **Proof of Insurance.** The Consultant shall not commence work under this Agreement until it has obtained all the insurance required by the Owner and the State of Wyoming and such insurance has been approved by the Owner and the State of Wyoming. Approval of insurance by the Owner and the State of Wyoming shall not relieve or decrease the liability of the Consultant. The Consultant shall file a Certificate of Insurance with the Owner verifying each type of coverage required.
- a. **Workers' Compensation and Employer's Liability Insurance.** The Consultant shall provide the Owner with a Certificate of Good Standing or other proof of workers' compensation coverage for all its employees who are to work on the project described in this Agreement. The Consultant's coverage shall be under the Wyoming Department of Workforce Services' workers' compensation program if statutorily required or such other private workers' compensation insurance, as appropriate. Non-Wyoming Consultant's insurance coverage shall also include Employer's Liability "Stop Gap" coverage, in an amount not less than five hundred thousand dollars (\$500,000.00) per employee for each accident and disease. The Consultant shall also supply proof of workers' compensation and employers' liability insurance, if required, for each and every subcontractor prior to allowing that subcontractor on the job site.

- b. **Commercial General Liability Insurance.** The Consultant shall provide commercial general liability insurance coverage, during the entire term of this Agreement, against claims arising out of bodily injury, death, damage to or destruction of the property of others, including loss of use thereof, and including underground collapse and explosion, and products and completed operations, in an amount not less than five hundred thousand dollars (\$500,000.00) per occurrence and one million dollars (\$1,000,000.00) general aggregate.
- c. **Business Automobile Liability Insurance.** The Consultant shall maintain during the entire term of this Agreement automobile liability insurance in an amount not less than five hundred thousand dollars (\$500,000.00) per occurrence.
- d. **Unemployment Insurance.** The Consultant shall be duly registered with the Department of Workforce Services and obtain such unemployment insurance coverage as required. Such coverage shall be maintained throughout the duration of this Agreement. The Consultant shall supply the Owner with a Certificate of Good Standing or other proof of unemployment insurance coverage for itself and each and every subcontractor prior to beginning work under this Agreement and at any time upon request of the Owner.
- e. **Payment of Premiums and Notice of Revocation.** All policies required under this Agreement shall be in effect for the duration of this Agreement. All policies shall be primary and not contributory. The Consultant shall pay the premiums on all insurance certificates which must include a clause stating that the insurance may not be revoked, canceled, amended, or allowed to lapse until the expiration of at least thirty (30) days advance written notice to the Owner.
- f. **The Owner May Insure for Contractor.** In case of a breach of any provision of this Section, the Owner or the State may, at the Owner's or State's option, purchase and maintain, at the expense of the Consultant, such insurance in the name of the Consultant, or subcontractor, as the Owner or the State may deem proper and may deduct the cost of taking out and maintaining such insurance from any sums which may be due or become due to the Consultant under this Agreement.
- g. **The Owner's Right to Reject.** The Owner reserves the right to reject a certificate of insurance if the Consultant's insurance company is widely regarded in the insurance industry as financially unstable.
- h. **The Owner's Right to Contact Insurer.** The Owner shall have the right to consult with the Consultant's insurance agent for disclosure of relevant policy information. Relevant information includes, but is not limited to:

- i. Exclusions from coverage;
- ii. Claims in progress which could significantly reduce the annual aggregate limit; and
- iii. Any applicable deductible amounts.

If the policy is a “claims made” policy instead of an “occurrence” policy, the information provided shall include, but not necessarily be limited to, retroactive dates and extended reporting periods or tails.

- i. Subcontractors. The insurance requirements set out above apply to all subcontractors. It is the Consultant’s responsibility to ensure that its subcontractors meet these insurance requirements. The Owner has the right to review the insurance certificates of any and all subcontractors used by the Consultant.

MM. **Severability.** Should any portion of this Agreement be judicially determined to be illegal or unenforceable, the remainder of the Agreement shall continue in full force and effect, and the parties may renegotiate the terms affected by the severance.

NN. **Sovereign Immunity and Limitations.** Pursuant to Wyo. Stat. § 1-39-101 *et seq.*, the State of Wyoming and the Owner expressly reserve sovereign and governmental immunity by entering into this Agreement and specifically retain all immunities and defenses available to them. The parties acknowledge that the State of Wyoming has sovereign immunity and only the Wyoming Legislature has the power to waive sovereign and governmental immunity. The parties further acknowledge that there are constitutional and statutory limitations on the authority of the Owner or the State of Wyoming and its agencies or instrumentalities to enter into certain terms and conditions supplied by the Consultant, including, but not limited to, the following: liability for damages; choice of law; conflicts of law; venue and forum-selection clauses; defense or control of litigation or settlement; liability for acts or omissions of third parties; payment of attorneys’ fees or costs; additional insured provisions; dispute resolution, including, but not limited to, arbitration; indemnification of another party; and confidentiality. Any such provisions in the Agreement, or in any attachments or documents incorporated by reference, will not be binding on the Owner or the State of Wyoming except to the extent authorized by the laws and Constitution of the State of Wyoming. Designations of venue, choice of law, enforcement actions, and similar provisions shall not be construed as a waiver of sovereign or governmental immunity. The parties agree that any ambiguity in this Agreement shall not be strictly construed, either against or for either party, except that any ambiguity as to sovereign immunity shall be construed in favor of sovereign or governmental immunity.

OO. **Taxes.** The Consultant shall pay all taxes and other such amounts required by federal, state, and local law, including, but not limited to, federal and social security taxes, workers' compensation, unemployment insurance, and sales taxes.

PP. **Termination of Agreement.** This Agreement may be terminated, without cause, by the Owner upon thirty (30) days' written notice. This Agreement may be terminated by the Owner immediately for cause if the Consultant fails to perform in accordance with the terms of this Agreement.

If at any time during the performance of this Agreement, in the opinion of the Owner, the work is not progressing satisfactorily or within the terms of this Agreement, then, at the discretion of the Owner and after written notice to the Consultant, the Owner may terminate this Agreement or any part of it. As of the termination date, the Consultant will be entitled to a pro rata payment for all work accomplished and accepted by the Owner; however, the Consultant shall be liable to the Owner for the entire cost of replacement services for the duration of the Agreement term.

QQ. **Third Party Beneficiary Rights.** The parties do not intend to create in any other individual or entity the status of third party beneficiary, and this Agreement shall not be construed so as to create such status. The rights, duties, and obligations contained in this Agreement shall operate only between the parties to this Agreement and shall inure solely to the benefit of the parties to this Agreement.

RR. **Time is of the Essence.** Time is of the essence in all provisions of this Agreement.

SS. **Titles Not Controlling.** Titles of sections and subsections are for reference only and shall not be used to construe the language in this Agreement.

TT. **Waiver.** The waiver of any breach of any term or condition in this Agreement shall not be deemed a waiver of any prior or subsequent breach. Failure to object to a breach shall not constitute a waiver.

UU. **Personnel.** The Consultant represents that it has, or will secure, all personnel required in performing the services under this Agreement. Such personnel shall not be employees of the City of Casper or the Casper Area Metropolitan Planning Organization. All of the services required hereunder shall be performed by the Consultant, or under its supervision, and all personnel engaged in the work shall be fully qualified. All personnel employed by Consultant shall be employed in conformity with applicable state or federal laws

VV. **Personnel Changes.** The City of Casper reserves the right to re-negotiate or terminate the Agreement if there is a change in 33% or more of the Consultant's key personnel or

with any change with the Consultant's Project Manager. In addition, the City may remove any key personnel from the Consultant's team if that person is deemed unsuitable or a hindrance to the cooperative completion of the project.

- WW. **Technical.** The Consultant shall provide a single point of contact to address technical issues and the distribution and receipt of data. Likewise, the City will provide a single technical contact to assure follow-through on deliverables. All GIS-based data will be disseminated and returned by Consultant in a standardized format (as defined by City IT Staff) that can easily be integrated with existing City of Casper data.
- XX. **Wyoming Governmental Claims Act.** The Owner does not waive any right or rights it may have pursuant to the Wyoming Governmental Claims Act, Wyoming Statutes Section 1-39-101 *et seq.*, and the Owner specifically reserve the right to assert any and all rights, immunities, and defenses it may have pursuant to the Wyoming Governmental Claims Act.
- YY. **Subconsultant.** The Consultant shall not employ any Subconsultant or Subcontractor to perform any services in the scope of this Project, unless said Subconsultant or Subcontractor is approved in writing by the Owner. Said Subconsultant shall be paid by the Consultant.
- ZZ. **Assignability.** The Consultant shall not assign any interest in this Agreement, and shall not transfer any interest in the same (whether by assignment or novation) without the prior written approval of the Owner: provided, however, that claims for money due or to become due the Consultant under this Agreement may be assigned to a bank, trust company, or other financial institution, or to a trustee in bankruptcy, without such approval. Notice of any assignment or transfer shall be furnished to the Owner.
- AAA. **Equal Employment Opportunity.** In carrying out the program, the Consultant shall not discriminate against any employee or applicant for employment because of race, color, religion, sex, national origin, or disability. The Consultant shall take affirmative action to insure that applicants for employment are employed, and that employees are treated during employment, without regard to their race, color, religion, sex, national origin, or disability. Such action shall include, but not be limited to the following: employment upgrading, demotion, or transfer; recruitment or recruitment advertising; layoff or termination; rates of pay or other forms of compensation; and selection for training, including apprenticeship. The Consultant shall post in conspicuous places, available to employees and applicants for employment, notices to be provided by the government setting forth the provisions of this nondiscrimination clause. The Consultant shall state that all qualified applicants will receive consideration for employment without regard to race, color, religion, sex, national origin, or disability.

- BBB. **Ownership of Project Materials.** It is agreed that all finished or unfinished documents, data, studies, surveys, graphics, drawings, maps, models, photographs, films, duplicating plates, and reports prepared by the Consultant under this Agreement shall be considered the property of the Owner, and upon completion of the services to be performed, they will be turned over to the Owner provided that, in any case, the Consultant may, at no additional expense to the Owner, make and retain such additional copies thereof as Consultant desires for its own use; and provided further, that in no event may any of the documents, data, studies, surveys, drawings, maps, models, photographs, films, duplicating plates, or other reports retained by the Consultant be released to any person, agency, corporation, or organization without the written consent of the Owner. Consultant shall not be liable for any modifications to documents prepared by Consultant which are made without its advice after delivery of such documents to Owner, nor shall Consultant be liable for their use by Owner without Consultant's consent in other projects.
- CCC. **Findings Confidential.** All reports, information, data, etc., given to or prepared, or assembled by the Consultant under this Agreement, shall be deemed confidential and none shall be made available to any individual or organization by the Consultant, except the owner, without the prior written consent of the Owner.
- DDD. **Governing Law.** This Agreement has been executed by the parties hereto on the day and year first above written and shall be governed by the laws of the State of Wyoming. The Consultant shall also comply with all applicable laws, ordinances, and codes of the federal, state, or local governments and shall not trespass on any public or private property in performing any of the work embraced by this Agreement.
- EEE. **Intent.** Consultant represents that it has read and agrees to the terms of this Agreement and further agrees that it is the intent of the parties that Consultant shall perform all of the services to be provided for the compensation set forth in this Agreement. Consultant also agrees that it is the specific intent of the parties, and a material condition of this Agreement, that it shall not be entitled to compensation for other services rendered unless specifically authorized by the Owner. Consultant agrees that it has made a careful examination of the services to be rendered, and that the Agreement price is adequate compensation for all the services to be rendered under the terms of this Agreement.
- FFF. **Pass Through Provisions.** Federal law requires the Consultant to include all relevant special provisions of this Agreement in every subcontract awarded over ten thousand dollars (\$10,000.00) so that such provisions are binding on each subcontractor.

Part III
FEDERAL CONTRACTUAL PROVISIONS

REQUIRED CLAUSES

To the extent applicable, federal requirements extend to third party consultants and their subcontracts and sub agreements at every tier. Accordingly the Consultant will agree to meet the following Federal requirements in order to enter into any contracts and agreements during the contract term. In addition the Consultant will agree to include, and to require that its subcontracts and sub agreements include, appropriate clauses in each subcontract and each sub agreements financed in whole or in part with financial assistance provided by the FTA under the Grant Agreement(s) or Cooperative Agreement(s) between the City of Casper and the FTA.

1. ACCESS TO RECORDS AND REPORTS

a. Record Retention. The Consultant will retain, and will require its subconsultants of all tiers to retain, complete and readily accessible records related in whole or in part to the contract, including, but not limited to, data, documents, reports, statistics, sub-agreements, leases, subcontracts, arrangements, other third party agreements of any type, and supporting materials related to those records.

b. Retention Period. The Contractor agrees to comply with the record retention requirements in accordance with 2 C.F.R. § 200.333. The Consultant shall maintain all books, records, accounts and reports required under this Contract for a period of at not less than three (3) years after the date of termination or expiration of this Contract, except in the event of litigation or settlement of claims arising from the performance of this Contract, in which case records shall be maintained until the disposition of all such litigation, appeals, claims or exceptions related thereto.

c. Access to Records. The Consultant agrees to provide sufficient access to FTA and its consultants to inspect and audit records and information related to performance of this contract as reasonably may be required.

d. Access to the Sites of Performance. The Consultant agrees to permit FTA and its consultants access to the sites of performance under this contract as reasonably may be required.

2. CLEAN AIR ACT AND FEDERAL WATER POLLUTION CONTROL ACT

The Consultant agrees to comply with all applicable standards, orders or regulations issued pursuant to the Clean Air Act (42 U.S.C. 7401–7671q) and the Federal Water Pollution Control Act as amended (33 U.S.C. 1251–1387). The Consultant agrees to report each violation to the City and understands and agrees that the City will, in turn, report each violation as required to assure notification to FTA and the appropriate EPA Regional Office.

The Consultant agrees:

1. It will not use any violating facilities;
2. It will report the use of facilities placed on or likely to be placed on the U.S. EPA “List of Violating Facilities;”

3. It will report violations of use of prohibited facilities to FTA; and
4. It will comply with the inspection and other requirements of the Clean Air Act, as amended, (42 U.S.C. §§ 7401 – 7671q); and the Federal Water Pollution Control Act as amended, (33 U.S.C. §§ 1251-1387).

3. CIVIL RIGHTS LAWS AND REGULATIONS

The Consultant is an Equal Opportunity Employer. As such, the Consultant agrees to comply with all applicable federal civil rights laws and implementing regulations. Apart from inconsistent requirements imposed by Federal laws or regulations, the Consultant agrees to comply with the requirements of 49 U.S.C. § 5323(h) (3) by not using any Federal assistance awarded by FTA to support procurements using exclusionary or discriminatory specifications. Under this Agreement, the Consultant shall at all times comply with the following requirements and shall include these requirements in each subcontract entered into as part thereof.

a. **Nondiscrimination.** In accordance with Federal transit law at 49 U.S.C. § 5332, the Consultant agrees that it will not discriminate against any employee or applicant for employment because of race, color, religion, national origin, sex, disability, or age. In addition, the Consultant agrees to comply with applicable Federal implementing regulations and other implementing requirements FTA may issue.

b. **Race, Color, Religion, National Origin, Sex.** In accordance with Title VII of the Civil Rights Act, as amended, 42 U.S.C. § 2000e *et seq.*, and Federal transit laws at 49 U.S.C. § 5332, the Consultant agrees to comply with all applicable equal employment opportunity requirements of U.S. Department of Labor (U.S. DOL) regulations, "Office of Federal Contract Compliance Programs, Equal Employment Opportunity, Department of Labor," 41 C.F.R. chapter 60, and Executive Order No. 11246, "Equal Employment Opportunity in Federal Employment," September 24, 1965, 42 U.S.C. § 2000e note, as amended by any later Executive Order that amends or supersedes it, referenced in 42 U.S.C. § 2000e note. The Consultant agrees to take affirmative action to ensure that applicants are employed, and that employees are treated during employment, without regard to their race, color, religion, national origin, or sex (including sexual orientation and gender identity). Such action shall include, but not be limited to, the following: employment, promotion, demotion or transfer, recruitment or recruitment advertising, layoff or termination; rates of pay or other forms of compensation; and selection for training, including apprenticeship. In addition, the Consultant agrees to comply with any implementing requirements FTA may issue.

c. **Age.** In accordance with the Age Discrimination in Employment Act, 29 U.S.C. §§ 621-634, U.S. Equal Employment Opportunity Commission (U.S. EEOC) regulations, "Age Discrimination in Employment Act," 29 C.F.R. part 1625, the Age Discrimination Act of 1975, as amended, 42 U.S.C. § 6101 *et seq.*, U.S. Health and Human Services regulations, "Nondiscrimination on the Basis of Age in Programs or Activities Receiving Federal Financial Assistance," 45 C.F.R. part 90, and Federal transit law at 49 U.S.C. § 5332, the Consultant agrees to refrain from discrimination against present and prospective employees for reason of age. In addition, the Consultant agrees to comply with any implementing requirements FTA may issue.

d. **Disabilities.** In accordance with section 504 of the Rehabilitation Act of 1973, as amended, 29 U.S.C. § 794, the Americans with Disabilities Act of 1990, as amended, 42 U.S.C. § 12101 *et seq.*, the Architectural Barriers Act of 1968, as amended, 42 U.S.C. § 4151 *et seq.*, and Federal transit law at 49 U.S.C. § 5332, the Consultant agrees that it will not discriminate against individuals on the basis of disability. In addition, the Consultant agrees to comply with any implementing requirements FTA may issue.

4. DISADVANTAGED BUSINESS ENTERPRISE (DBE)

DBE participation has not been established for this procurement. The Consultant shall not discriminate on the basis of race, color, national origin, or sex in the performance of this contract. The consultant shall carry out applicable requirements of 49 C.F.R. part 26 in the award and administration of DOT-assisted contracts. Failure by the Consultant to carry out these requirements is a material breach of this contract, which may result in the termination of this contract or such other remedy as the City deems appropriate, which may include, but is not limited to:

1. Withholding monthly progress payments;
2. Assessing sanctions;
3. Liquidated damages; and/or
4. Disqualifying the Consultant from future bidding as non-responsible. 49 C.F.R. § 26.13(b).

5. ENERGY CONSERVATION

The Consultant agrees to comply with mandatory standards and policies relating to energy efficiency, which are contained in the state energy conservation plan issued in compliance with the Energy Policy and Conservation Act.

6. GOVERNMENT-WIDE DEBARMENT AND SUSPENSION

This contract is a covered transaction for purposes of 49 CFR Part 29. As such, the Consultant is required to verify that its principals, affiliates, and subconsultants are eligible to participate in this federally funded contract and are not presently declared by any Federal department or agency to be,

1. Debarred from participation in any federally assisted Award;
2. Suspended from participation in any federally assisted Award;
3. Proposed for debarment from participation in any federally assisted Award;
4. Declared ineligible to participate in any federally assisted Award;
5. Voluntarily excluded from participation in any federally assisted Award; or
6. Disqualified from participation in any federally assisted Award.

7. LOBBYING RESTRICTIONS

No federal funds under this contract may be used to influence or attempt to influence an officer or employee of any agency, a member of Congress, an officer or employee of Congress, or an employee of a member of Congress in connection with obtaining any federal contract, grant or any other award covered by 31 U.S.C. 1352.

8. NO GOVERNMENT OBLIGATION TO THIRD PARTIES

The City and Consultant acknowledge and agree that, notwithstanding any concurrence by the Federal Government in or approval of the solicitation or award of the underlying Contract, absent the express written consent by the Federal Government, the Federal Government is not a party to this Contract and shall not be subject to any obligations or liabilities to the City, Consultant or any other party (whether or not a party to that contract) pertaining to any matter resulting from the underlying Contract. The Consultant agrees to include the above clause in each subcontract financed in whole or in part with Federal assistance provided by the FTA. It is further agreed that the clause shall not be modified, except to identify the subconsultant who will be subject to its provisions.

9. PATENT RIGHTS AND RIGHTS IN DATA

Intellectual Property Rights

This project is funded through a Federal award with FTA for experimental, developmental, or research work purposes. As such, certain Patent Rights and Data Rights apply to all subject data first produced in the performance of this contract. The consultant shall grant the consultant intellectual property access and licenses deemed necessary for the work performed under the contract and in accordance with the requirements of 37 C.F.R. part 401, "Rights to Inventions made by Nonprofit Organizations and Small Business Firms Under Government Grants, Contract and Cooperative Agreements," and any implementing regulations issued by FTA or U.S. DOT. The terms of an intellectual property agreement and software license rights will be finalized prior to execution of this contract and shall, at a minimum, include the following restrictions: Except for its own internal use, the Consultant may not publish or reproduce subject data in whole or in part, or in any manner or form, nor may the Consultant authorize others to do so, without the written consent of FTA, until such time as FTA may have either released or approved the release of such data to the public. This restriction on publication, however, does not apply to any contract with an academic institution. For purposes of this contract, the term "subject data" means recorded information whether or not copyrighted, and that is delivered as required by the Contract. Examples of "subject data" include, but are not limited to computer software, standards, specifications, engineering drawings and associated lists, process sheets, manuals, technical reports, catalog item identifications, and related information, but do not include financial reports, cost analyses, or other similar information used for performance or administration of the Contract.

A. The Federal Government receives a royalty-free, non-exclusive and irrevocable license to reproduce, publish, or otherwise use, and to authorize others to use for "Federal Government Purposes," any subject data or copyright described below. For "Federal Government Purposes,"

means use only for the direct purposes of the Federal Government. Without the copyright owner's consent, the Federal Government may not extend its Federal license to any other party.

1. Any Subject data developed under the Contract, whether or not a copyright has been obtained; and
2. Any rights of copyright purchased by the Consultant using Federal assistance in whole or in part by the FTA.

B. Unless FTA determines otherwise, the Consultant performing experimental, developmental, or research work required as part of this Contract agrees to permit FTA to make available to the public, either FTA's license in the copyright to any subject data developed in the course of the Contract, or a copy of the subject data first produced under the Contract for which a copyright has not been obtained. If the experimental, developmental, or research work, which is the subject of this Contract, is not completed for any reason whatsoever, all data developed under the Contract shall become subject data as defined herein and shall be delivered as the Federal Government may direct.

C. Unless prohibited by state law, upon request by the Federal Government, the Consultant agrees to indemnify, save, and hold harmless the Federal Government, its officers, agents, and employees acting within the scope of their official duties against any liability, including costs and expenses, resulting from any willful or intentional violation by the Consultant or proprietary rights, copyrights, or right of privacy, arising out of the publication, translation, reproduction, delivery, use, or disposition of any data furnished under that contract. The Consultant shall be required to indemnify the Federal Government for any such liability arising out of the wrongful act of any employee, official, or agents of the Federal Government.

D. Noting contained in this clause on rights in data shall imply a license to the Federal Government under any patent or be construed as affecting the scope of any license or other right otherwise granted to the Federal Government under any patent.

E. Data developed by the Consultant and financed entirely without using Federal assistance provided by the Federal Government that has been incorporated into work required by the underlying Contract is exempt from the requirements herein, provided that the Consultant identifies those data in writing at the time of delivery of the Contract work.

F. The Consultant agrees to include these requirements in each subcontract for experimental, developmental, or research work financed in whole or in part with Federal assistance.

10. PROGRAM FRAUD AND FALSE OR FRAUDULENT STATEMENTS AND RELATED ACTS

The Consultant acknowledges that the provisions of the Program Fraud Civil Remedies Act of 1986, as amended, 31 U.S.C. § 3801 *et seq.* and U.S. DOT regulations, "Program Fraud Civil Remedies," 49 C.F.R. part 31, apply to its actions pertaining to this Project. Upon execution of the underlying contract, the Consultant certifies or affirms the truthfulness and accuracy of any

statement it has made, it makes, it may make, or causes to be made, pertaining to the underlying contract or the FTA assisted project for which this contract work is being performed. In addition to other penalties that may be applicable, the Consultant further acknowledges that if it makes, or causes to be made, a false, fictitious, or fraudulent claim, statement, submission, or certification, the Federal Government reserves the right to impose the penalties of the Program Fraud Civil Remedies Act of 1986 on the Consultant to the extent the Federal Government deems appropriate. The Consultant also acknowledges that if it makes, or causes to be made, a false, fictitious, or fraudulent claim, statement, submission, or certification to the Federal Government under a contract connected with a project that is financed in whole or in part with Federal assistance originally awarded by FTA under the authority of 49 U.S.C. chapter 53, the Government reserves the right to impose the penalties of 18 U.S.C. § 1001 and 49 U.S.C. § 5323(l) on the Consultant, to the extent the Federal Government deems appropriate.

The Consultant agrees to include the above two clauses in each subcontract financed in whole or in part with Federal assistance provided by FTA. It is further agreed that the clauses shall not be modified, except to identify the subconsultant who will be subject to the provisions.

11. SAFE OPERATION OF MOTOR VEHICLES

In compliance with Federal Executive Order No. 13043, "Increasing Seat Belt Use in the United States," April 16, 1997, 23 U.S.C. Section 402 note, the City of Casper has adopted seat belt use and distracted driving policies and programs.

Seat Belt Use: The Consultant is encouraged to adopt and promote on-the-job seat belt use policies and programs for its employees and other personnel that operate company-owned vehicles, company- A-60 rented vehicles, or personally operated vehicles. The terms "company-owned" and "company-leased" refer to vehicles owned or leased either by the Consultant or the City.

Distracted Driving The Consultant agrees to adopt and enforce workplace safety policies to decrease crashes caused by distracted drivers, including policies to ban text messaging while using an electronic device supplied by an employer, and driving a vehicle the driver owns or rents, a vehicle Contactor owns, leases, or rents, or a privately-owned vehicle when on official business in connection with the work performed under this agreement.

12. TERMINATION

The City may terminate this contract, in whole or in part, at any time by written notice to the Consultant when it is in the City's best interest. The Consultant shall be paid its costs, including contract close-out costs, and profit on work performed up to the time of termination. The Consultant shall promptly submit its termination claim to the City to be paid the Consultant. If the Consultant has any property in its possession belonging to the City, the Consultant will account for the same, and dispose of it in the manner the City directs.

If the Consultant does not deliver supplies in accordance with the contract delivery schedule, or if the contract is for services, the Consultant fails to perform in the manner called for in the contract,

or if the Consultant fails to comply with any other provisions of the contract, the City may terminate this contract for default. Termination shall be effected by serving a Notice of Termination on the Consultant setting forth the manner in which the Consultant is in default. The Consultant will be paid only the contract price for supplies delivered and accepted, or services performed in accordance with the manner of performance set forth in the contract.

If it is later determined by the City that the Consultant had an excusable reason for not performing, such as a strike, fire, or flood, events which are not the fault of or are beyond the control of the Consultant, the City, after setting up a new delivery of performance schedule, may allow the Consultant to continue work, or treat the termination as a Termination for Convenience.

The City, in its sole discretion may, in the case of a termination for breach or default, allow the Consultant 10 to 14 days in which to cure the defect. In such case, the Notice of Termination will state the time period in which cure is permitted and other appropriate conditions.

If Consultant fails to remedy to the City's satisfaction the breach or default of any of the terms, covenants, or conditions of this Contract within 10 days after receipt by Consultant of written notice from the City setting forth the nature of said breach or default, the City shall have the right to terminate the contract without any further obligation to Consultant. Any such termination for default shall not in any way operate to preclude the City from also pursuing all available remedies against Consultant and its sureties for said breach or default.

If this Contract is terminated while the Consultant has possession of the City's goods, the Consultant shall, upon direction of the City, protect and preserve the goods until surrendered to the City or its agent. The Consultant and the City shall agree on payment for the preservation and protection of goods. Failure to agree on an amount will be resolved under the Dispute clause.

If, after termination for failure to fulfill contract obligations, it is determined that the Consultant was not in default, the rights and obligations of the parties shall be the same as if the termination had been issued for the convenience of the City.

13. VIOLATION AND BREACH OF CONTRACT

The Consultant agrees to provide all professional services as required by the terms, conditions, provisions, and obligations of this Agreement. Failure by the Consultant to perform as required by the terms, conditions, provisions, or obligations of this Agreement shall constitute a breach of agreement. The City of Casper will consider a Consultant's failure to perform as a material breach of agreement when it can be determined that the terms, conditions, provisions, or obligations of the Agreement cannot be completed and the City of Casper will incur additional cost, lost opportunity, or additional time to obtain the same or equal Agreement deliverables. A material breach may result in remedies as the City of Casper deems appropriate, which may include, but are not limited to:

1. Termination as provided in Section 12 – Termination of Agreement;
2. Withholding monthly progress payments;

3. Assessing damages/sanctions;
4. Disqualifying the Consultant from future solicitations; and/or
5. Legal remedy.

14. DETERMINATION OF ALLOWABLE COSTS

The Consultant shall assure, prior to submittal of periodic progress payments, that all costs are in accordance with federal cost principals as provided in 48 CFR 31. Failure by the Consultant to carry out these requirements may be a material breach of this Agreement, which may result in remedies as provided in Section 13 – Violation and Breach of Contract.

15. ERRORS AND OMISSIONS

The Consultant shall be responsible for assuring that professional services provided under this Agreement are accurate. The Consultant shall endeavor to perform services in a manner consistent with that degree of care and skill ordinarily exercised by members of the same profession currently practicing under similar circumstances (Standard/Duty of Care). The City of Casper will notify the Consultant at the earliest possible time of the professional services which require corrective action and the Consultant, by mutual agreement with the City of Casper and without additional compensation, shall correct those services. Failure by the Consultant to carry out these requirements may be a material breach of this Agreement, which may result in remedies as provided in Section 13 – Violation and Breach of Contract.

16. PROFESSIONAL REGISTRATION

The Consultant shall endorse, if required by law, plans and reports prepared under this Agreement, and shall affix thereto his or her seal of professional registration, showing that he or she is licensed to practice in the State of Wyoming.

17. TITLE VI ASSURANCES FOR NON-DISCRIMINATION

The Consultant agrees to comply with the requirements of the nondiscrimination clauses described further in Exhibit C, which is attached to and incorporated into this Agreement by this reference.

EXHIBIT “A”

SCOPE OF SERVICES



Task 1. Project Management

Quality project and contract management is always a critical element of every project’s success. At the heart of effective project management is excellent communication. After the approved contract, Project Manager **Joe DeVore, PE, PTOE, RSP2** will establish a detailed communication plan with Casper Area MPO staff and the project team. Joe has experience and expertise managing projects that require extensive coordination and schedule management and this project is expected to have a fast timeline to maintain the project budget.

Joe will organize a monthly Project Management Team (PMT) meeting to provide project updates and foster collaboration among the team and stakeholders. The PMT will include KIJ, Casper Area MPO staff, Town of Evansville, WYDOT, and other agency stakeholders as needed. These members will be anticipated to attend and participate in each project meeting. As work progresses or needs arise, invitations will be extended to other key stakeholders to collect their input and expertise for the project.

TASK 2. AGENCY & PUBLIC INVOLVEMENT

Led by **Wade Kline, PTP**, the team will coordinate with Casper Area MPO upon award to create a public engagement plan that will engage and inform the public and stakeholders during project development. The focus of this task will be to inform project stakeholders about project progress, inform residents on possible alternatives, and seek input on access and alignment options. Monthly agency stakeholder meetings will be scheduled for the project that will include Casper Area MPO officials, Town staff, and other identified stakeholders. Some areas where additional stakeholder input could prove valuable may include.

- Existing Issues and Project Needs
- Preliminary Alternative Screening
- Alternative Selection
- Specific Property Impacts

The public involvement process will be focused on local businesses and local residents that use the roadway network. Several public engagement tools will be considered when developing the public engagement plan, including a combination of in-person engagement, such as open houses and area resident meetings, and virtual engagement, which can include website updates, social media, and digital ads – appropriate for engaging motorists throughout the project area. Design drawings and alternative layouts will all be shared with the public throughout the process. In preparing for public engagement activities, our team will lean on a group of advisors consisting of key stakeholders and interested members of the public. Having trusted advisors in the community will ensure messaging, materials, and participation by the public is aligned with both public input and analysis.

AFFECTED BUSINESS OUTREACH MEETINGS

KIJ will make initial in-person contact with affected businesses in the project area to encourage business representatives to provide existing issues and alternative feedback during the project. This will allow businesses an opportunity to share and identify how a potential new intersection may change their everyday operations.

TASK 3 VISUALIZATIONS

Visualizations will be created as part of the project to be used by both the project team and public to visualize operations of the intersection alternatives. KIJ will integrate each of the proposed intersection alternatives into Vistro / Vissim models used for traffic operations analysis to show the complete corridor operations between alternatives. This integration of visualizations into the traffic operations analysis helps reduce overall time and budget constraints but also provides the ability to compare realistic operations between alternatives visually versus just from the traffic operations level of service (LOS) results.



TASK 4 DATA COLLECTION & TRAFFIC ANALYSIS

Data collection will start with a thorough review of planning documents from the Casper Area MPO and Evansville to identify previously identified alternatives, analysis, and planning level information for the study area. The Lathrop Road Traffic Study identified several access management recommendations including access consolidation and implementation of a raised median that will provide needed safety benefits.

Traffic data collection, operations, and safety analysis tasks will be led by **Mark Powers, PE, PTOE**. KIJ recognizes that improving intersection operations and safety is the primary goal of this project. KIJ will collect 13-hour turning movement counts at the study intersection to identify both peak and midday traffic volumes and use StreetLight historical turning movement data to identify traffic volume differences between summer and in-school periods validating this data with published annual average daily traffic (AADT) volumes. The traffic analysis will be completed by utilizing PTV Vistro, a macrosimulation tool that uses Highway Capacity Manual (HCM) methodology to review the intersection operations and safety. KIJ will follow Federal Highway Administration's (FHWA) ICE process to complete an ICE report to include a focus on what intersection alternative provides the safest and best operations to the study area.

An in-depth safety analysis will be conducted using the existing crash data. Intersection crash records will be analyzed to prepare a safety comparison to identify the existing safety deficiencies and to set a baseline for future safety benefits.

TASK 5 UTILITY IDENTIFICATION

Jen Brassfield, PE will lead the utility coordination as part of the concept design. With the concept level design (10 percent), she will start to identify owners and verify utility location of any local and private utilities in the vicinity of the proposed intersection and extended roadway. Jen will review provided utility maps and identify alignments that mitigate existing utility impacts such as the existing transmission lines running parallel to the proposed extension.

TASK 6 ALTERNATIVES ANALYSIS

KIJ's alternatives analysis process will be a technical evaluation of project criteria, easily summarized in an evaluation matrix for project stakeholders to select an alternative that best balances the purpose and needs of the project. Potential alternatives will be identified that will address the deficiencies identified as part of the existing and future baseline. Results of the operations and safety analysis will be used in a Benefit-Cost analysis quantifying the yearly benefits using a combination of the scenario results.

An evaluation matrix will be developed matching value profile results from the engagement task weighting the results on stakeholder input and on technical results for each of the comparison criteria. Key objectives include affordability, safety, stakeholder coordination, ROW impacts, and efficient roadway operation/transportation design. Following the environmental process, a preferred alternative will be selected from the alternatives evaluation results.

TASK 7 10% GEOMETRIC DESIGN

Development of the geometric layout will tie closely with public engagement and traffic engineering tasks, seeking to meet the purpose, need, and vision for the project. Led by Jen Brassfield, the team will work directly with Mark Powers during traffic analysis and alternatives analysis to help develop solutions to technical challenges and drive the project forward to a preferred alternative. Concept layouts will be created for each alternative identified that can be used to review ROW impacts, estimate project costs, and display the various safety benefits to the public and stakeholders. As alternatives are developed, Jen and Mark will work closely with our public engagement team to present the findings during the geometric design of the preferred alternative to find a solution that meets the goals of the project. With a preferred alternative selected, we will finish development of the 10 percent design document.

EXHIBIT "B"

MPO POLICY COMMITTEE APPROVAL

WHEREAS, the Casper Area Metropolitan Planning Organization Policy Committee approved the MPO Unified Planning Work Program (UPWP) Budget on the Evansville Texas Street Extension Study; and,

WHEREAS, on September 20, 2022, the Consultant Selection Committee approved the hiring of KLJ Engineering LLC, 4585 Coleman Street, Bismarck, North Dakota, 58503-0431, to complete the Evansville Texas Street Extension Study; and,

WHEREAS, KLJ Engineering LLC, is willing, available and qualified to perform said work.

NOW, THEREFORE BE IT RESOLVED BY THE MPO POLICY COMMITTEE: That the City of Casper, as the agent of the MPO, is hereby directed to enter into the Agreement with KLJ Engineering LLC, to complete the Evansville Texas Street Extension Study in accordance with the Agreement, for an amount not to exceed Thirty-Nine Thousand Nine Hundred Forty-Six Dollars and Eighty-Two Cents (\$39,946.82).

PASSED AND APPROVED THIS 6th day of June, 2022.

ATTEST:

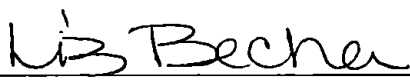

Liz Becher
Community Development Director

CASPER AREA METROPOLITAN PLANNING
ORGANIZATION POLICY COMMITTEE

Sabrina Kemper
Chairwoman

EXHIBIT “C”

NOTICE TO CONSULTANT COMPLIANCE WITH TITLE VI OF THE CIVIL RIGHTS ACT OF 1964 FOR FEDERAL-AID CONTRACTS

During the performance of this KLJ Engineering LLC, for itself, its assignees and successors in interest (hereinafter referred to as the Consultant), agrees as follows:

1. Compliance with Regulations.

The Consultant will comply with the Regulations of the Department of Transportation relative to nondiscrimination in federally-assisted programs of the Department of Transportation (Title 49, Code of Federal Regulations, Part 21, hereinafter referred to as the Regulations), which are herein incorporated by reference and made a part of this contract.

2. Nondiscrimination.

The Consultant, with regard to the work performed by it after award and prior to completion of the Contract work, will not discriminate on the grounds of race, color, national origin, or disability in the selection and retention of subconsultants, including procurements of materials and leases of equipment. The Consultant will not participate either directly or indirectly in the discrimination prohibited by any state or federal law including, but not limited to, Section 21.5 of the Regulations, including employment practices, when the contract covers a program set forth in Appendix B of the Regulations.

3. Solicitations for Subcontracts, Including Procurements of Materials and Equipment.

In all solicitations, either by competitive bidding or negotiation made by the Consultant for work to be performed under a subcontract, including procurements or materials or equipment, each potential subconsultant or supplier shall be notified by the Consultant of the Consultant’s obligations under this Contract and the Regulations relative to nondiscrimination on the ground of race, color, or national origin.

4. Information and Reports.

The Consultant will provide all information and reports required by the Regulations, or orders and instructions issued pursuant thereto, and will permit access to its books, records, accounts, other sources of information and its facilities as may be determined by the MPO Policy Committee, WYDOT, or FHWA to be pertinent to ascertain compliance with such regulations, orders, and instructions. Where any information required of a Consultant is in the exclusive possession of another who fails or refuses to furnish this information, the Consultant shall so certify to the MPO Policy Committee, WYDOT, or FHWA as appropriate, and shall set forth what efforts it has made to obtain the information.

5. Sanctions for Noncompliance.

In the event of the Consultant's noncompliance with the nondiscrimination provisions of this contract, the MPO Policy Committee shall impose such contract sanctions as it or WYDOT or the FHWA may determine to be appropriate, including, but not limited to:

- A. Withholding of payments to the Consultant under the contract until the Consultant complies; and/or,
- B. Cancellation, termination, or suspension of the contract, in whole or in part.

6. Incorporation of Provisions.

The Consultant shall include the provisions of Paragraph 1 through 6 in every subcontract, including procurements of materials and leases of equipment, unless exempt by the regulations, order, or instructions issued pursuant thereto. The Consultant will take such action with respect to any subcontract or procurement as the MPO Policy Committee, WYDOT, or the FHWA may direct as a means of enforcing such provisions, including sanctions for noncompliance. Provided, however, that, in the event a Consultant becomes involved in, or is threatened with, litigation with a subconsultant or supplier as a result of such direction, the Consultant may request the United States to enter into such litigation to protect the interests of the United States.

EXHIBIT "D"

CERTIFICATION OF CONSULTANT

I hereby certify that I, Mark Anderson, am the SVP of and duly authorized representative of the firm of KLJ Engineering LLC; and that neither I nor the above firm I here represent has:

1. Employed or retained for a commission, percentage, brokerage fee, contingent fee, or other consideration, any firm or person (other than a bona fide employee working solely for me or the above Consultant) to solicit or secure this Agreement;
2. Agreed, as an express or implied condition for obtaining this Agreement, to employ or retain the services of any firm or person in connection with carrying out the Agreement; or,
3. Paid, or agreed to pay, to any firm, organization, or person (other than a bona fide employee working solely for me or the above Consultant) any fee, contribution, donation, or consideration of any kind for, or in connection with, procuring or carrying out the Agreement, except as here expressly stated (if any).

I acknowledge that this Certification is to be given to the Casper Area Metropolitan Planning Organization, and is subject to applicable state and federal laws, both criminal and civil.

10-3-2022
Date

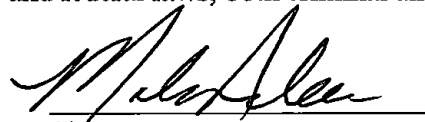
Signature

Mark Anderson
Printed Name

SVP
Title

EXHIBIT "E"

CERTIFICATE OF AGENT

I hereby certify that I am the designated AGENT of the City of Casper, Wyoming, a Municipal Corporation, and that the above consulting firm or its representatives have not been required, directly or indirectly as an express or implied condition in connection with obtaining or carrying out this Contract to:

1. Employ or retain, or agree to employ or retain, any firm or person; or,
2. Pay, or agree to pay, to any firm, person, or organization any fee, contribution, donation, or consideration of any kind; with no exceptions.

I acknowledge that this Certification is subject to applicable state and federal laws, both criminal and civil.

ATTEST:

CITY OF CASPER, WYOMING
A Municipal Corporation:

Date _____

Ray Pacheco
Mayor

EXHIBIT "F"

CERTIFICATION OF
SUSPENSION OR DEBARMENT

STATE OF NORTH Dakota) ss

COUNTY OF Burleigh) ss

I, Mark Anderson, being duly sworn on oath, certify that neither I, nor any person associated therewith in the capacity of Owner, partner, director, or officer is currently under suspension, debarment, voluntary exclusion, or determination of ineligibility by any state or federal agency; have been suspended, debarred, voluntarily excluded, or determined ineligible by any state or federal agency within the past three years; have a proposed debarment pending; and, nor have been indicted, convicted, or had a civil judgment rendered against (it) by a court of competent jurisdiction in any matter involving fraud or official misconduct within the past three years.

By: *Mark Anderson*

SVP
Title

Subscribed in my presence and sworn to before me this 3rd day of October, 2022, by:

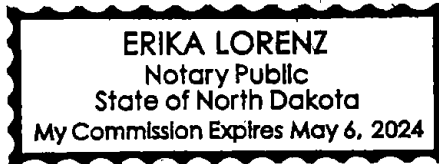

Erika Lorenz

Notary Public



May 6, 2024
My Commission Expires

EXHIBIT "G"
FEE SCHEDULE

KLJ Project Name: Texas St Extension KLJ Project Number: 2213-01104 Client: Casper Area MPO		 		Project Budget								
Staff Type		Project Manager	Traffic Engineer	Senior Design Review	Public Engagement I	Public Engagement I	Roadway Design	Project Assistant	DIRECT LABOR Subtotal	DIRECT EXPENSE	TASK TOTAL	
Staff Name		Joe DeVore	Mark Powers	Steve Grabill	Wade Kline	Laura Langdon	Jen Bransfield	Megan Wohl				
Hourly Rate		\$50.00	\$48.08	\$65.44	\$61.61	\$39.42	\$41.27	\$22.36				
1	Project Management											
	Invoicing	6						6	\$434.16		\$434.16	
	PM Biweekly Meetings	6							\$300.00		\$300.00	
	Task 1 Subtotal	12						6	\$734.16		\$734.16	
2	Agency and Public Engagement											
	Agency PM Meetings	4	4		4		4		\$803.84		\$803.84	
	Business Engagement	4			4	26			\$1,471.36		\$1,471.36	
	Open House	4			4	26			\$1,471.36		\$1,471.36	
	Task 2 Subtotal	12	4		12	52	4		\$3,746.56		\$3,746.56	
3	Visualizations											
	VISSIM Visuals	6							\$300.00		\$300.00	
	Task 3 Subtotal	6							\$300.00		\$300.00	
4	Data Collection and Traffic Analysis											
	Traffic Counts	2	16						\$869.28	\$1,500.00	\$2,369.28	
	Operations Analysis	2	8						\$484.64		\$484.64	
	Safety Analysis	2	8						\$484.64		\$484.64	
	Task 4 Subtotal	6	32						\$1,838.56	\$1,500.00	\$3,338.56	
5	UTILITY IDENTIFICATION											
	Utility Review	1					8		\$380.16		\$380.16	
	Task 5 Subtotal	1					8		\$380.16		\$380.16	
6	ALTERNATIVES ANALYSIS											
	Benefit Cost Analysis	1	4						\$242.32		\$242.32	
	Evaluation Matrix	2	8						\$484.64		\$484.64	
	Task 6 Subtotal	3	12						\$726.96		\$726.96	
7	10% GEOMETRIC DESIGN											
	Concept Layout	2		1			16		\$826.16		\$826.16	
	Cost Estimate	2					8		\$430.16		\$430.16	
	10% Design Documents	2		2			32		\$1,552.32		\$1,552.32	
	Final Report	4	16	1			2		\$1,113.96		\$1,113.96	
	Task 7 Subtotal	10	16	4			56		\$3,922.60		\$3,922.60	
	Total Hours	50	64	4	12	54	68	6	258			
									Total Dollars	\$11,649.00	\$1,500.00	\$13,149.00

Summary of Costs: WYDOT		
Direct Labor		\$11,649.00
Indirect Costs - 193.76%		\$22,564.11
	Subtotal	\$34,213.11
On bill rate / Fixed Fee	12.00%	\$4,105.57
Raw labor cost / COF - 1.10%		\$128.14
	Direct Expenses	\$1,500.00
Total Estimated Engineering Costs		\$39,946.82

RESOLUTION NO. 22-185

A RESOLUTION AUTHORIZING A CONTRACT BETWEEN THE CITY OF CASPER AND KLJ ENGINEERING, LLC., FOR THE EVANSVILLE TEXAS STREET EXTENSION STUDY.

WHEREAS, the Cities of Casper and Mills, Wyoming, the Towns of Evansville and Bar Nunn, Wyoming, Natrona County, Wyoming, and the Wyoming Department of Transportation entered into an Agreement, dated April 13, 1983, to provide for the cooperative, comprehensive, and continuing (3-C) transportation planning for the area of Casper, Wyoming and its environs; and,

WHEREAS, the Casper Area Transportation Planning Process (hereinafter described as the "CATPP") acts as the Metropolitan Planning Organization (hereinafter referred to as the "MPO") for the Casper Urbanized Area for the distribution of Federal Aid Planning Funds; and,

WHEREAS, the parties of the CATPP appointed the City to enter into contracts for and on behalf of the CATPP and to further act as the CATPP's Fiscal Manager in an Agreement Amendment dated April 19, 2005; and,

WHEREAS, any contract entered into by the City on behalf of the CATPP requires the approval of a majority of the voting members of the Policy Committee prior to its execution and implementation by the City; and,

WHEREAS, the MPO Policy Committee approved the MPO Unified Planning Work Program (UPWP) Budget on June 16, 2022, for a Evansville Texas Street Extension Study, not to exceed Forty Thousand Dollars and Zero Cents (\$40,000.00); and,

WHEREAS, the MPO released a request for proposal (RFP) for consulting groups that specialize in corridor planning and design on August 5, 2022; and,

WHEREAS, the Project Selection Committee selected KLJ Engineering, LLC., on September 20, 2022, to complete Evansville Texas Street Extension Study.

NOW, THEREFORE, BE IT RESOLVED BY THE GOVERNING BODY OF THE CITY OF CASPER, WYOMING: That the Mayor is hereby authorized and directed to execute, and the City Clerk to attest, a Contract for Professional Services between the City of Casper, Wyoming, and KLJ Engineering, LLC., on behalf of the Casper Area Metropolitan Planning Organization in the amount of Thirty-Nine Thousand Nine Hundred Forty-Six Dollars and Eighty-Two Cents (\$39,946.82) for the Evansville Texas Street Extension Study.

PASSED, APPROVED, AND ADOPTED on this ___ day of _____, 2022.

APPROVED AS TO FORM:



ATTEST:

CITY OF CASPER, WYOMING
A Municipal Corporation

Fleur Tremel
City Clerk

Ray Pacheco
Mayor

October 11, 2022

MEMO TO: J. Carter Napier, City Manager *JCN*

FROM: Jill Johnson, Financial Services Director *JJ*
Brandy Coyle, Accounts Receivable Supervisor

SUBJECT: Transition to a Service Fee Model for Utility Merchant Processing Accounts with DrivePayments

Meeting Type & Date

Council Meeting
October 18, 2022

Action type

Resolution

Recommendation

Transition utility merchant processing accounts to a service fee model. This would charge the processing/service fee to the customer instead of the City absorbing the fee for customers who use credit/debit cards.

Summary

The City currently utilizes DrivePayments and BDS to process our debit/credit card charges for utility payments, community development, solid waste, police, cemetery, engineering, and metro. Permits and Court are eligible however additional work with the software would be required to convert those departments to the service fee model.

Currently, the City is charged a reduced service fee, 1.3%, for utility bills paid with credit cards. If the service fee was transitioned to the customer, the customer would pay a 2.95% service fee. Additionally, if the bill was under \$2.00, the customer would pay a minimum fee of \$2.00 for using their card. The fee does not change based on the type of card (debit or credit); the same minimum/% is charged for all transactions processed.

The City accepts multiple tenders including cash, checks, money orders, ACH and cards; cards are not the only way to pay a bill. The service fee can be eliminated by the customer using a different tender. The table below provides a comparison between costs to the City versus the cost to the customer.

Bill amount	City Cost	Cust. Cost	Upcharge
25.00	0.33	2.00	1.26
50.00	0.65	2.00	0.53
100.00	1.30	2.95	
500.00	6.50	14.75	
1,000.00	13.00	29.50	

The customer paying the service fee is not a new concept, other governments and businesses throughout the Casper area have gone to this model and it is no longer considered a cost of doing business but is instead viewed as a customer convenience.

After discussion at the September 27, 2022 work session, the current resolution transitions only utility payments for customers who are using a debit/credit card. Additional resolutions will be presented for approval as the City continues to transition other areas to the Service Fee Model.

Budgetary Impacts

The FY23 budget for utility customer service credit card fees is \$120,000. The transition to the service fee model, if approved, is not expected to be completed until December 31, 2022 which reduces the estimated actual savings for FY23 to \$60,000 or ½ of the year for the utility accounts.

A one-time cost of \$11,475 would be needed for updated card processing equipment which will come out of the budget savings.

Oversight/Project Responsibility

Brandy Coyle, Accounts Receivable Supervisor

Attachment

Resolution

RESOLUTION NO. 22-186

A RESOLUTION AUTHORIZING TRANSITION TO A SERVICE FEE MODEL FOR UTILITY CREDIT/DEBIT CARD PAYMENTS.

WHEREAS, the City of Casper desires to transition from the City absorbing the credit card fee to the customer paying the credit card fee (service fee model); and,

WHEREAS, the City of Casper desires to implement a service fee model change on all utility customers who pay with a credit/debit card; and,

WHEREAS, the current credit card processor is able and willing to implement this change to be effective January 1, 2023.

NOW, THEREFORE, BE IT RESOLVED BY THE GOVERNING BODY OF THE CITY OF CASPER, WYOMING: That the City Manager is hereby authorized to make the transition of utility credit/debit card payments to comport with the service fee model.

PASSED, APPROVED, AND ADOPTED on this ___ day of _____, 2022.

APPROVED AS TO FORM:

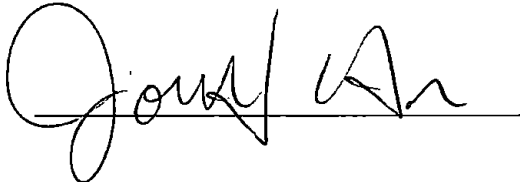

ATTEST:

CITY OF CASPER, WYOMING
A Municipal Corporation

Fleur D. Tremel
City Clerk

Ray Pacheco
Mayor

October 5, 2022

MEMO TO: City Council
J. Carter Napier, City Manager *znl*

FROM: Jill Johnson, Financial Services Director *JJ*
Brandy Coyle, Accounts Receivable Supervisor *BC*

SUBJECT: Request for Release of Various Local Assessment District Liens in Local Assessment District 158 Coates Road.

Meeting Type & Date
Regular Council Meeting
October 18, 2022

Action type
Resolution

Recommendation
That City Council, by resolution, authorize a *Partial Release of Lien*, in reference to various assessments that have been satisfied within Coates Road Local Assessment District 158.

Summary
The City of Casper completed LAD 158 which improved various properties in the City of Casper. Ordinance No. 4-22 recorded with the Natrona County Clerk on May 24, 2022, as Instrument No. 1124652 and a lien was placed on the properties within the assessment district. Various property owners, as listed on Exhibit 1 of the *Partial Lien Release*, have paid their assessment in full and for consideration of payment, the City of Casper should release the assessment district lien pertaining to their property.

Find attached a Resolution Authorizing the Release of Various Local Assessment District Liens Regarding Coates Road Local Assessment District 158.

Financial Considerations
\$29,832.19 recovered.

Oversight/Project Responsibility
Financial Services
City Attorney's Office

Attachments
Resolution
Partial Release of Lien

PARTIAL RELEASE OF LIEN

The City of Casper, Wyoming, a Wyoming municipal corporation, 200 North David Street, Casper, Wyoming 82601, completed Local Assessment District 158, which improved various properties in the City of Casper, Wyoming.

Ordinance No. 4-22 was passed, adopted and approved on May 17, 2022, and was recorded with the Natrona County Clerk on May 24, 2022, as Instrument No. 1124652.

A Notice of Recording of Assessment Roll was recorded with the Natrona County Clerk as Instrument No. _____ on the _____ day of October 2022. The Local Assessment District Lien created by Ordinance 4-22 and the Notice of Recording of the Assessment Roll described above has been satisfied regarding the properties legally describe below, and for consideration of payment of the assessment, the City of Casper does hereby release the Lien regarding the properties identified below.

Please remove the Lien from the following properties:

Common Address	Legal Description	Lien Amt.
4390 Coates Rd.	TRACT 3, SKYLINE RANCHES SUBDIVISION, NATRONA COUNTY, WYOMING, AS PER PLAT RECORDED DECEMBER 26, 1973, IN BOOK 250 OF DEEDS, PAGE 489.	\$5,045.88
4380 Coates Rd.	TRACT 4, SKYLINE RANCHES SUBDIVISION, NATRONA COUNTY, WYOMING, AS PER PLAT RECORDED DECEMBER 26, 1973, IN BOOK 250 OF DEEDS, PAGE 489.	\$2,460.96
4350 Coates Rd.	TRACT 5, SKYLINE RANCHES SUBDIVISION, NATRONA COUNTY, WYOMING, AS PER PLAT RECORDED DECEMBER 26, 1973, IN BOOK 250 OF DEEDS, PAGE 489.	\$4,340.12
4145 Coates Rd.	TRACT 10, SKYLINE RANCHES SUBDIVISION, NATRONA COUNTY, WYOMING, AS PER PLAT RECORDED DECEMBER 26, 1973, IN BOOK 250 OF DEEDS, PAGE 489.	\$2,728.53
4215 Coates Rd.	TRACT 11, SKYLINE RANCHES SUBDIVISION, NATRONA COUNTY, WYOMING, AS PER PLAT RECORDED DECEMBER 26, 1973, IN BOOK 250 OF DEEDS, PAGE 489.	\$2,794.81
4110 Coates Rd.	A PORTION OF LOT 8, SKYLINE RANCHES SUBDIVISION, NATRONA COUNTY, WYOMING, AS PER MORTGAGE RECORDED AUGUST 22, 2003, INSTRUMENT NO. 724534.	\$2,505.14
4085 Coates Rd.	TRACT 9, SKYLINE RANCHES SUBDIVISION, NATRONA COUNTY, WYOMING, AS PER PLAT RECORDED DECEMBER 26, 1973, IN BOOK 250 OF DEEDS, PAGE 489, EXCEPTING A PORTION OF SAID TRACT 9, AS PER	\$2,598.43

	MORTGAGE RECORDED OCTOBER 30, 2001, INSTRUMENT NO. 680725.	
4255 Coates Rd.	A PORTION OF LOT 12, SKYLINE RANCHES SUBDIVISION, NATRONA COUNTY, WYOMING, AS PER QUIT CLAIM DEED RECORDED MARCH 15, 2018, INSTRUMENT NO. 1044617.	\$2,451.14
4355 Coates Rd.	A PORTION OF LOT 14, SKYLINE RANCHES SUBDIVISION, NATRONA COUNTY, WYOMING, AS PER WARRANTY DEED RECORDED APRIL 3, 2017, INSTRUMENT NO. 1028628.	\$2,454.82
4375 Coates Rd.	A PORTION OF LOTS 12, 13 AND 14, SKYLINE RANCHES SUBDIVISION, NATRONA COUNTY, WYOMING, AS PER MORTGAGE RECORDED AUGUST 2, 2013, INSTRUMENT NO. 956023.	\$ 985.61
4425 Coates Rd.	A PORTION OF LOTS 12, 13 AND 14, SKYLINE RANCHES SUBDIVISION, NATRONA COUNTY, WYOMING, AS PER QUIT CLAIM DEED RECORDED JUNE 16, 2020, INSTRUMENT NO. 1083050.	\$1,466.75
4045 Coates Road	A PORTION OF TRACT 9, SKYLINE RANCHES SUBDIVISION, NATRONA COUNTY, WYOMING, AS PER THE EXCEPTED PORTION OF SAID TRACT 9 IN MORTGAGE RECORDED OCTOBER 30, 2001, INSTRUMENT NO. 680725.	\$227.26

APPROVED AS TO FORM:

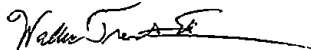

ATTEST:

City of Casper, Wyoming,
a municipal corporation

Fleur Tremel
City Clerk

Ray Pacheco
Mayor

State of Wyoming)
County of Natrona)

This instrument was acknowledged before me on the _____ day of _____
_____, 2022, by Ray Pacheco, Mayor of the City of Casper, Wyoming.

(Seal)

My Commission Expires:

Notary Public

Exhibit 1

Common Address	Legal Description	Lien Amt.
4390 Coates Rd.	TRACT 3, SKYLINE RANCHES SUBDIVISION, NATRONA COUNTY, WYOMING, AS PER PLAT RECORDED DECEMBER 26, 1973, IN BOOK 250 OF DEEDS, PAGE 489.	\$5,045.88
4380 Coates Rd.	TRACT 4, SKYLINE RANCHES SUBDIVISION, NATRONA COUNTY, WYOMING, AS PER PLAT RECORDED DECEMBER 26, 1973, IN BOOK 250 OF DEEDS, PAGE 489.	\$2,460.96
4350 Coates Rd.	TRACT 5, SKYLINE RANCHES SUBDIVISION, NATRONA COUNTY, WYOMING, AS PER PLAT RECORDED DECEMBER 26, 1973, IN BOOK 250 OF DEEDS, PAGE 489.	\$4,340.12
4145 Coates Rd.	TRACT 10, SKYLINE RANCHES SUBDIVISION, NATRONA COUNTY, WYOMING, AS PER PLAT RECORDED DECEMBER 26, 1973, IN BOOK 250 OF DEEDS, PAGE 489.	\$2,728.53
4215 Coates Rd.	TRACT 11, SKYLINE RANCHES SUBDIVISION, NATRONA COUNTY, WYOMING, AS PER PLAT RECORDED DECEMBER 26, 1973, IN BOOK 250 OF DEEDS, PAGE 489.	\$2,794.81
4110 Coates Rd.	A PORTION OF LOT 8, SKYLINE RANCHES SUBDIVISION, NATRONA COUNTY, WYOMING, AS PER MORTGAGE RECORDED AUGUST 22, 2003, INSTRUMENT NO. 724534.	\$2,505.14
4085 Coates Rd.	TRACT 9, SKYLINE RANCHES SUBDIVISION, NATRONA COUNTY, WYOMING, AS PER PLAT RECORDED DECEMBER 26, 1973, IN BOOK 250 OF DEEDS, PAGE 489, EXCEPTING A PORTION OF SAID TRACT 9, AS PER MORTGAGE RECORDED OCTOBER 30, 2001, INSTRUMENT NO. 680725.	\$2,598.43
4255 Coates Rd.	A PORTION OF LOT 12, SKYLINE RANCHES SUBDIVISION, NATRONA COUNTY, WYOMING, AS PER QUIT CLAIM DEED RECORDED MARCH 15, 2018, INSTRUMENT NO. 1044617.	\$2,451.14
4355 Coates Rd.	A PORTION OF LOT 14, SKYLINE RANCHES SUBDIVISION, NATRONA COUNTY, WYOMING, AS PER WARRANTY DEED RECORDED APRIL 3, 2017, INSTRUMENT NO. 1028628.	\$2,454.82
4375 Coates Rd.	A PORTION OF LOTS 12, 13 AND 14, SKYLINE RANCHES SUBDIVISION, NATRONA COUNTY, WYOMING, AS PER MORTGAGE RECORDED AUGUST 2, 2013, INSTRUMENT NO. 956023.	\$ 985.61
4425 Coates Rd.	A PORTION OF LOTS 12, 13 AND 14, SKYLINE RANCHES SUBDIVISION, NATRONA COUNTY, WYOMING, AS PER QUIT CLAIM DEED RECORDED JUNE 16, 2020, INSTRUMENT NO. 1083050.	\$1,466.75
4045 Coates Road	A PORTION OF TRACT 9, SKYLINE RANCHES SUBDIVISION, NATRONA COUNTY, WYOMING, AS PER THE EXCEPTED PORTION OF SAID TRACT 9 IN MORTGAGE RECORDED OCTOBER 30, 2001, INSTRUMENT NO. 680725.	\$227.26

RESOLUTION NO. 22-187

A RESOLUTION AUTHORIZING THE RELEASE OF VARIOUS LOCAL ASSESSMENT DISTRICT LIENS REGARDING COATES ROAD LOCAL ASSESSMENT DISTRICT 158.

WHEREAS, the City of Casper, Wyoming, completed Local Assessment District No. 158, which improved various properties in the City of Casper, Wyoming, located within the Assessment District; and,

WHEREAS, Ordinance No. 4-22, was passed, adopted and approved on May 17, 2022, and was recorded with the Natrona County Clerk on May 24, 2022, as Instrument No. 1124652; and,

WHEREAS, the above described ordinance ratified the actions taken by the City of Casper concerning the Assessment District, confirmed the proceedings, assessment roll and the assessment thereon of the properties in the Assessment District and created a lien on the properties listed on the assessment roll; and,

WHEREAS, the property owners identified in Exhibit 1, attached hereto and made part of this Resolution, have paid their assessment in full, and for consideration the Lien pertaining to the properties legally described on Exhibit 1 should be released by execution and recreation of a Partial Release of Lien.

NOW, THEREFORE, BE IT RESOLED BY THE GOVERNING BODY OF THE CITY OF CASPER, WYOMING: that the Mayor is hereby authorized to execute, and the City Clerk to attest a Partial Release of Lien, releasing the lien regarding the property legally described on Exhibit 1.

PASSED, APPROVED, AND ADOPTED this ___ day of _____, 2022.

APPROVED AS TO FORM:



ATTEST:

Fleur Tremel
City Clerk

CITY OF CASPER, WYOMING
A Municipal Corporation

Ray Pacheco
Mayor

September 27, 2022

MEMO TO: J. Carter Napier, City Manager *JN*

FROM: Andrew Beamer, P.E., Public Services Director
Bruce Martin, Public Utilities Director
Alex Sveda, P.E., City Engineer *AS*
Steven Stolte, E.I.T., Associate Engineer I

SUBJECT: Authorizing a Contract for Professional Services with WLC Engineering, Surveying, and Planning, Inc., in the amount of \$370,098.00, for the Westridge Addition Improvements, Project No. 21-065.

Meeting Type & Date:

Regular Council Meeting
October 18, 2022

Action Type:

Resolution

Recommendation:

That Council, by resolution, authorize a contract for professional services with WLC Engineering, Surveying, and Planning, Inc. (WLC), in the amount of \$370,098.00, for the Westridge Addition Improvements, Project No. 21-065.

Summary:

The City is working on street, sidewalk, and utility improvements for the Westridge Addition: Phase 1 includes Westridge Circle, Westridge Terrace, Westridge Drive, Westridge Lane, and Westwood Hill. Phase 2 includes Westridge Way, Westridge Place, and Westridge Court.

The City Engineering department requested proposals from local consultants for professional services including engineering design and establishing a Local Assessment District (LAD) for Phases 1 and 2, with bidding and construction administration services for Phase 1 only.

Four (4) firms submitted proposals and three (3) were interviewed for the requested services. Based on their qualifications, WLC was selected. City staff recommends awarding WLC the work, in the amount of \$370,098.00. Current Phase 1 and Phase 2 construction costs are estimated to be \$1,605,000 and \$1,166,000, respectively, totaling \$2,771,000.

Financial Considerations

Funding for this project will be from FY23 1%16 funds allocated to water main replacement and FY23 1%16 fund allocated to Streets.

Oversight/Project Responsibility

Steven Stolte, E.I.T., Associate Engineer I

Attachments

Resolution

Agreement

CONTRACT FOR PROFESSIONAL SERVICES

PART I - AGREEMENT

This Contract for Professional Services (“Contract”) is entered into on this ____ day of _____, 2022, by and between the following parties:

1. The City of Casper, Wyoming, a Wyoming municipal corporation, 200 North David Street, Casper, Wyoming 82601 (“City” or “Owner”).

2. Worthington, Lenhart, and Carpenter, Inc., 200 Pronghorn Drive, Casper, Wyoming 82601 (“Consultant”).

Throughout this document, the City and the Consultant may be collectively referred to as the “parties.”

RECITALS

A. The City is undertaking a project for utility replacements and street/sidewalk improvements in the Westridge Area.

B. The project requires professional services for the engineering design, establishing a Local Assessment District (LAD), bidding, and construction administration services for the work.

C. The Consultant represents that it is ready, willing, and able to provide the professional services to City as required by this Contract.

D. The City desires to retain the Consultant for such services.

NOW, THEREFORE, in consideration of the covenants and conditions set forth herein to be performed, the parties agree as follows:

1. SCOPE OF SERVICES:

The Scope of Services shall, at a minimum, include the following:

Phase 1:

A. Design Phase.

1. The Consultant shall meet with City representatives to discuss proposed project configuration and layout.

2. The Consultant shall conduct field surveys to collect topographic data, existing utilities, and surface elevations for the purpose of providing an appropriate alignment and to establish grades needed to provide positive drainage throughout the corridor.
3. The Consultant shall prepare plan sheets that have been approved and signed by a licensed Professional Engineer registered in the State of Wyoming. The plan sheets shall include the proposed area showing the final elevations, grades, alignments, typical sections, right-of-way and utility plans, and all details necessary for construction, and other details necessary to insure safe passage for the public.
4. The Consultant shall prepare final drawings on a computer-aided drafting format. Digital format shall be DXF and be compatible with AUTOCAD Version 2020 release or later. The Consultant shall also provide a final set of plans in 11x17 paper copy designated as "Bid Set" approved and signed by a licensed Professional Engineer registered in the State of Wyoming, and a complete set of plans electronically in a pdf format that can be printed as a complete set and to scale, ready for reproduction if needed and all CAD file associated to the project. The project will be designed and presented to the City of Casper in accordance with Casper Municipal Code 16.16.020.
5. The Consultant shall prepare, and submit to the City Engineering Office, a project cost estimate when preliminary plans are at approximately fifty percent (50%) complete, at ninety percent (90%) complete, and at the completion of the design at One Hundred percent (100%).
6. Consultant shall provide the City Engineering Office Two (2) hard copies (paper) and digital PDF copies of the preliminary construction drawings and project manuals to be reviewed by City Staff at 50% and 90% and to conduct review meetings involving city staff to go over all comments at each phase.
7. Consultant shall be responsible for coordination with the Department of Environmental Quality (DEQ) and other entities as required to obtain a permit to construct the improvements. It is anticipated that Geotech Investigations must be conducted in order to obtain a permit to construct from the DEQ. A preliminary geotechnical investigation was performed in 2022 and is available upon request. Consultant shall conduct and include all additional geotechnical investigations necessary for design, permitting, and construction of the work.

8. Consultant shall provide assistance to City staff in the LAD processes. This assistance shall include providing figures, quantities, measurements, communications, and methods of assessment.

B. Project Manual.

1. Consultant shall prepare Technical Specifications covering the required work for the Project.
2. Consultant shall prepare Construction Drawings and Specifications in accordance with the City of Casper Standard Specifications for Public Works Construction and Infrastructure Improvements.
3. General Conditions and Supplemental Conditions of the Specifications shall be based on current City of Casper approved documents.
4. The Consultant shall prepare a Project Manual to include the following:
 - a. Technical Specifications.
 - b. Bid Schedule to accompany the Owner's Bid Form.
 - c. Edited "front end" documents of the Project Manual supplied by the City Engineering Office. Documents supplied will consist of Advertisement for Bids, Instruction to Bidders, Performance and Payment Bonds, Bid Bond and Form, Agreement between Owner and Contractor, General Conditions, and Supplementary Conditions. Consultant shall review these documents, insert modifications where necessary, and return them for final review. After front end documents are reviewed by the Owner, Consultant shall incorporate any changes into the Project Manual.

The Consultant shall affix his professional engineer's stamp, date, and signature to the front cover of the project manual and in accordance with Wyoming State Registration Statutes.

C. Final Bidding Documents.

1. The Consultant shall provide the City Engineering Office one (1) hard copy set (paper) and one (1) digital PDF set of Bidding Documents at the completion of the design. The Consultant shall affix his registration stamp, date, and signature to the Bidding Documents in accordance with Wyoming State Registration Statutes.

2. The Consultant shall submit to the City, at a minimum, final drawings consisting of plan sheets showing all necessary details related to this project, and as follows:
 - a. Title Sheet that shows the project limits and location with respect to the surrounding region. This sheet shall also have an index and legend. The sheet shall bear the Consultants registration stamp, date and signature.
 - b. Typical Section of the roadway with dimensions and stationing.
 - c. Right-of-Way & Utility Plan indicating clearance of right-of-way and plan and profiles of all utilities to be replaced or modified.
 - d. Grading Plan showing the grades and direction of drainage for any runoff with proposed and existing elevations.
 - e. Drainage Details showing size and location of drainage features if necessary.
 - f. Corridor Amenities details showing location and orientation, necessary for construction including: concrete sidewalk, curb and gutter, ADA ramps, etc.
 - g. Other Details.
3. The Consultant shall provide the City Engineering Office a copy of final drawings of the project in AUTOCAD and PDF formats, and the project manual in Microsoft word and PDF format labeled "BIDDING DOCUMENTS PHASE ONE WESTRIDGE IMPROVEMENTS PROJECT".

D. Advertising and Bidding:

1. The Consultant shall utilize and maintain project information with City of Casper's QuestCDN and QuestvBid websites for the following: advertisement, distributing addenda and bidding information to planholders, uploading project documents including all plans and specifications, and distributing bid tabulations to planholders.
2. Consultant shall schedule, organize, and conduct a prebid meeting and distribute meeting minutes. Consultant shall answer questions of prospective bidders. The meeting shall be a minimum of ten (10) days prior to the bid opening.

3. Consultant shall prepare and distribute addenda through QuestCDN and QuestvBid, if necessary.
4. Consultant shall assist the City in opening, tabulating, and evaluating bids.
5. The Consultant shall provide a written opinion to the Casper Engineering Office stating their recommendation for awarding the bid.

E. Construction:

1. General Administration of Construction Contract. Consultant shall consult with and advise Owner and act as Owner's representative as provided in Articles 1 through 17, inclusive, of the Standard General Conditions of the Construction Contract, No. 1910-8 (1990 edition) of the Engineers' Joint Contract Documents Committee, as amended by the Supplementary Conditions. The extent and limitations of the duties, responsibilities and authority of Consultant, as assigned in said Standard General Conditions, as amended, shall not be modified, except as Consultant and Owner may otherwise agree in writing. All of Owner's instructions to Contractor(s) will be issued through Consultant who will have authority to act on behalf of Owner to the extent provided in said Standard General Conditions, as amended, except as otherwise provided in writing. Consultant shall meet with Owner throughout the construction phase as deemed necessary by the Consultant or Owner, but not less than one (1) time per week.
2. Pre-construction Conference. Consultant shall organize and conduct a pre-construction conference with the successful bidder, and shall invite representatives of all affected utilities, the City staff, and the project team. The Consultant will prepare minutes of this conference for future reference, and shall supply a copy to the Owner. At this conference, the Consultant will deliver up to five (5) copies of the Contract Documents to the successful bidder.
3. Project Coordination. Consultant shall be responsible for coordination with the Department of Environmental Quality (DEQ) and other entities as required to construct the improvements, as well as with all affected property owners within the project areas. This shall include timely notification of construction activities as necessary and the procurement of all necessary certifications from the appropriate agency or agencies.
4. Visits to Site and Observation of Construction. In connection with observations of the Work of Contractor(s) while it is in progress:

- a. Consultant shall make visits to the site at intervals appropriate to the various stages of construction as Consultant deems necessary in order to observe as an experienced and qualified design professional the progress and quality of the various aspects of Contractor(s)' work. Consultant shall provide the services of a Resident Project Representative (RPR) at the site to assist Consultant and to provide observation of such Work. Based on information obtained during such visits and on such observations, Consultant shall endeavor to determine if such Work is proceeding in accordance with the Contract Documents, and Consultant shall keep Owner informed of the progress of the Work. The RPR will be on site for an average of six (6) hours per day, depending on the activities of the Contractor(s) and the progression of the Work.
- b. The RPR will be Consultant's agent or employee and under Consultant's supervision.
 - i. The purpose of Consultant's visits to and representation by the RPR at the site will be to enable Consultant to carry out the duties and responsibilities assigned to, and undertaken, by Consultant during the construction phase, and, in addition, by exercise of Consultant's efforts as an experienced and qualified design professional, to provide Owner with a degree of confidence that the completed Work of Contractor(s) will conform to the Contract Documents and that the integrity of the design concept as reflected in the Contract Documents has been implemented and preserved by Contractor(s). Subject to other terms of this agreement, Consultant shall not, during such visits or as a result of such observations of Contractor(s)' Work in progress, supervise, direct, or have control over Contractor(s)' Work, nor shall Consultant have authority over or responsibility for the means, methods, techniques, sequences or procedures of construction selected by Contractor(s), for safety precautions and programs incident to the Work of Contractor(s) or for any failure of Contractor(s) to comply with Laws and Regulations applicable to Contractor(s) furnishing and performing their Work.
 - ii. Accordingly, Consultant can neither guarantee the performance of the construction contracts by Contractor(s) nor assume responsibility for Contractor(s)' failure to furnish and perform their Work in accordance with the Contract Documents. During such visits, and based on his on-site

observations, as an experienced and qualified design professional, Consultant shall keep Owner informed of the progress of the Work, and will alert Owner to defects and deficiencies in the Work of Contractor(s) and may disapprove or reject Work as failing to conform to the Contract Documents.

- c. Consultant shall prepare daily reports of the Contractor(s)' activities and maintain an accurate daily "construction diary". Construction diary shall contain notes of all materials installed each day, and any and all pertinent conversations with the Contractor(s) or other entities on behalf of the Owner, a copy of which shall be given to Owner no less frequently than one (1) time each week during construction of the Project.
- d. Consultant shall maintain a digital photograph log during the course of construction. Photograph notations shall contain the direction of the photo, a brief description of the activity and date, and the photo number. The photograph log shall be delivered to the Owner upon completion of the Project. Photographs shall be taken randomly during critical stages of construction, but in no event shall they be taken less than once a week.
- e. Consultant shall maintain a correspondence file, including but not limited to, all memoranda, correspondence, and minutes of the progress meetings.
- f. During construction, progress meetings to include Owner's representative, Consultant, and Contractor(s) and subcontractors, as applicable, shall be held on a weekly basis. Consultant shall be responsible for keeping minutes of these progress meetings, and for circulating the minutes to all attendees within four (4) days following the meeting.
- g. In order to track progress of construction, Consultant shall prepare weekly progress reports to be provided to the Owner. This report shall include information on major progress during the past week, assess construction progress with respect to the Contractor(s)' construction schedule, and note any outstanding claims or potential changes in the scope of the project as identified or conveyed to Consultant during that week of construction activity. Consultant shall sign this report and obtain a signature from the Contractor(s) that he is in agreement.

5. Construction Staking. Consultant shall provide limited construction staking services for the Contractor(s), as follows:
 - a. Establish horizontal and vertical control for construction.
 - b. All staking will be done once, and Contractor(s) will be responsible for additional staking at his cost.
6. Defective Work. During such visits and on the basis of such observations, Consultant may disapprove of or reject Contractor(s)' Work while it is in progress if Consultant believes that such Work does not conform to the Contract Documents or that it will prejudice the integrity of the design concept of the Project as reflected in the Contract Documents.
7. Interpretations and Clarifications. Consultant shall issue necessary interpretations and clarifications of the Contract Documents and in connection therewith evaluate, prepare and process Work Directive Changes and Change Orders as required, for submittal to Owner.
8. Shop Drawings. Consultant shall review and approve, or take other appropriate action with respect to, Shop Drawings (as that term is defined in the aforesaid Standard General Conditions), samples and other data which Contractor(s) are required to submit, but only for conformance with the design concept of the Project and compliance with the information given in the Contract Documents. Such reviews and approvals or other action shall not extend to means, methods, techniques, sequences or procedures of construction or to safety precautions or programs incident thereto.
9. Substitutes. Consultant shall evaluate and determine the acceptability of substitute materials and equipment proposed by Contractor(s).
10. Inspection and Tests. Consultant shall provide for material testing as specified in the Contract Documents and the City of Casper Standard Specifications for Public Works Construction and Infrastructure Improvements.
11. Disputes between Owner and Contractor. Consultant shall act as initial interpreter of the requirements of the Contract Documents and judge of the acceptability of the Work thereunder and make decisions on all claims of Owner and Contractor(s) relating to the acceptability of the Work thereunder or the interpretation of the requirements of the Contract Documents pertaining to the execution and progress of the Work. Consultant shall not be liable for the results of any such interpretations or decisions rendered in good faith. Owner reserves the right to render final

decisions on all Contractor(s) claims, acceptability of the Work, and interpretation of the requirements of the Contract Documents.

12. Applications for Payment. Based on Consultant's on-site observations as an experienced and qualified design professional, on information provided by the Resident Project Representative and on review of Applications for Payment and the accompanying data and schedules:
 - a. Consultant shall determine the amounts owing to Contractor(s) and recommend, in writing, payments to Contractor(s) in such amounts. Such recommendations of payment will constitute a representation to Owner, based on such observations and review, that the Work has progressed to the point indicated, and that, to the best of Consultant's knowledge, information and belief, the quality of such Work is in accordance with the Contract Documents (subject to an evaluation of such Work as a functioning whole prior to or upon Substantial Completion, to the results of any subsequent tests called for in the Contract documents, and to any other qualifications stated in the recommendation). In the case of Unit Price Work, Consultant's recommendations of payment will include final determinations of quantities and classifications of such Work (subject to any subsequent adjustments allowed by the Contract Documents).
 - b. By recommending any payment, Consultant will not thereby be deemed to have represented that exhaustive, continuous or detailed reviews or examinations have been made by Consultant to check the quality or quantity of Contractor(s)' Work as it is furnished and performed beyond the responsibilities specifically assigned to Consultant in this Contract and the Contract Documents. Consultant's review of Contractor(s)' Work for the purposes of recommending payments will not impose on Consultant responsibility to supervise, direct or control such Work, or for the means, methods, techniques, sequences, or procedures of construction or safety precautions or programs incident thereto or Contractor(s)' compliance with Laws and Regulations applicable to their furnishing and performing the Work. It will also not impose responsibility on Consultant to make any examination to ascertain how or for what purposes any Contractor(s) has used the monies paid on account of the Contract Price, or to determine that title to any of the Work, materials, or equipment has passed to Owner free and clear of any lien, claims, security interests or encumbrances, or that there may not be other matters at issue between Owner and Contractor that might affect the amount that should be paid.

13. Contractor(s)' Completion Documents. Consultant shall receive and review tests and approvals which are to be assembled by Contractor(s) in accordance with the Contract Documents (but such review will only be to determine that their content complies with the requirements of, and in the case of tests and approvals the results certified indicate compliance with, the Contract Documents), and shall transmit them to Owner with written comments.
14. Walk-Through. Consultant shall conduct a walk-through with the City to determine if the Work is Substantially Complete and a final walk-through to determine if the completed work is acceptable so that Consultant may recommend, in writing, final payment to Contractor(s) and may give written notice to Owner and the Contractor(s) that the Work is acceptable (subject to any conditions therein expressed), but any such recommendation and notice will be subject to limitations expressed in paragraph I.E.12.b (Construction Phase).
15. Record Drawings. Consultant shall provide the Owner one (1) set of electronic drawings showing those changes made during the construction process, based on the marked-up prints, drawings, and other data furnished by Contractors to Consultant and which Consultant considers significant. Consultant shall also maintain a regularly updated set of "as-constructed" blueprints indicating Consultant(s)' observations of "as-constructed" Work performed by the Contractor(s). Within thirty (30) days of Substantial Completion, Consultant shall submit one (1) reproducible set of 11"x 17" record drawings to Owner. Consultant shall also provide to Owner a copy of record drawings in PDF and Autocad (in conformance with City of Casper Municipal Code 16.16.020 and United States National CAD Standards). format compatible with the Owners system, labeled as "Record Drawings – Westridge Improvements - Project No. 21-065".
16. Warranty Period Inspections. Consultant shall perform warranty period inspections for completed construction, during a one (1) year period after Final Completion of the construction phase. Warranty inspections shall include, but not be limited to, assisting Owner in addressing public complaints concerning construction deficiencies during the warranty period, attending an on-site project inspection walk-through of the project and preparing a listing of noted construction deficiencies at approximately eleven (11) months after the Final Completion date for construction, and follow-up.
17. Change Orders. Consultant shall evaluate and make recommendations for all requests for change orders during the construction of the Work.

Consultant shall prepare and submit construction change orders along with all necessary documentation to the Owner for approval.

18. **Limitation of Responsibilities.** Unless otherwise provided for in this Contract, Consultant shall not be responsible for the acts or omissions of any Contractor(s), or of any Subcontractor or Supplier, or any of the Contractor(s)' or Subcontractor(s)' or Supplier(s)' agents or employees or any other persons (except Consultant's own employees and agents) at the site or otherwise furnishing or performing any of the Contractor(s)' Work; however, nothing contained in paragraphs I.E.1 through I.E.17 (Construction Phase), inclusive shall be construed to release Consultant from liability for failure to properly perform duties and responsibilities assumed by Consultant in the Contract Documents.
19. Consultant shall provide assistance to City staff in the LAD process which shall include providing figures, quantities, measurements, communications, and methods of assessment.

Phase Two

A. Design Phase

1. The Consultant shall meet with City representatives to discuss proposed project configuration and layout.
2. The Consultant shall conduct field surveys to collect topographic data, existing utilities, and surface elevations for the purpose of providing an appropriate alignment and to establish grades needed to provide positive drainage throughout the corridor.
3. The Consultant shall prepare plan sheets that have been approved and signed by a licensed Professional Engineer registered in the State of Wyoming. The plan sheets shall include the proposed area showing the final elevations, grades, alignments, typical sections, right-of-way and utility plans, and all details necessary for construction, and other details necessary to insure safe passage for the public.
4. The Consultant shall prepare final drawings on a computer-aided drafting format. Digital format shall be DXF and be compatible with AUTOCAD Version 2020 release or later. The Consultant shall also provide a final set of plans in 11x17 paper copy designated as "Bid Set" approved and signed by a licensed Professional Engineer registered in the State of Wyoming, and a complete set of plans electronically in a pdf format that can be printed as a complete set and to scale, ready for reproduction if needed and all CAD

file associated to the project. The project will be designed and presented to the City of Casper in accordance with Casper Municipal Code 16.16.020.

5. The Consultant shall prepare, and submit to the City Engineering office, a project cost estimate when preliminary plans are at approximately fifty percent (50%) complete, at ninety percent (90%) complete, and at the completion of the design at One Hundred percent (100%).
6. Consultant shall provide the City Engineering Office Two (2) hard copies (paper) and digital PDF copies of the preliminary construction drawings and project manuals to be reviewed by City Staff at 50% and 90% and to conduct review meetings involving city staff to go over all comments at each phase.
7. Consultant shall be responsible for coordination with the Department of Environmental Quality (DEQ) and other entities as required to obtain a permit to construct the improvements. It is anticipated that Geotech Investigations must be conducted in order to obtain a permit to construct from DEQ. A preliminary geotechnical investigation was performed in 2022 and is available upon request. Consultant shall conduct and include all additional geotechnical investigations necessary for design, permitting, and construction of the work.
8. Consultant shall provide assistance to City staff in the LAD processes. This assistance shall include providing figures, quantities, measurements, communications, and methods of assessment.

B. Project Manual.

1. Consultant shall prepare Technical Specifications covering the required work for the Project.
2. Consultant shall prepare Construction Drawings and Specifications in accordance with the City of Casper Standard Specifications for Public Works Construction and Infrastructure Improvements.
3. General Conditions and Supplemental Conditions of the Specifications shall be based on current City of Casper approved documents.
4. The Consultant shall prepare a Project Manual to include the following:
 - a. Technical Specifications.
 - b. Bid Schedule to accompany the Owner's Bid Form.

- c. Edited "front end" documents of the Project Manual supplied by the City Engineering Office. Documents supplied will consist of Advertisement for Bids, Instruction to Bidders, Performance and Payment Bonds, Bid Bond and Form, Agreement between Owner and Contractor, General Conditions, and Supplementary Conditions. Consultant shall review these documents, insert modifications where necessary, and return them for final review. After front end documents are reviewed by the Owner, Consultant shall incorporate any changes into the Project Manual.

The Consultant shall affix his professional engineer's stamp, date, and signature to the front cover of the project manual and in accordance with Wyoming State Registration Statutes.

C. Final Bidding Documents.

1. The Consultant shall provide the City Engineering Office one (1) hard copy set (paper) and one (1) digital PDF set of Bidding Documents at the completion of the design. The Consultant shall affix his registration stamp, date, and signature to the Bidding Documents in accordance with Wyoming State Registration Statutes.
2. The Consultant shall submit to the City, at a minimum, final drawings consisting of plan sheets showing all necessary details related to this project, and as follows:
 - a. Title Sheet that shows the project limits and location with respect to the surrounding region. This sheet shall also have an index and legend. The sheet shall bear the Consultants registration stamp, date and signature.
 - b. Typical Section of the roadway with dimensions and stationing.
 - c. Right-of-Way & Utility Plan indicating clearance of right-of-way and plan and profiles of all utilities to be replaced or modified.
 - d. Grading Plan showing the grades and direction of drainage for any runoff with proposed and existing elevations.
 - e. Drainage Details showing size and location of drainage features if necessary.

f. Corridor Amenities details showing location and orientation, necessary for construction including: concrete sidewalk, curb and gutter, ADA ramps, etc.

g. Other Details.

3. The Consultant shall provide the City Engineering Office a copy of final drawings of the project in AUTOCAD and PDF formats, and the project manual in Microsoft word and PDF format labeled "BIDDING DOCUMENTS PHASE TWO WESTRIDGE IMPROVEMENTS PROJECT."

2. TIME OF PERFORMANCE:

The services of the Consultant shall be undertaken and completed on or before the 18th day of October 2024.

3. COMPENSATION:

In consideration of the performance of services rendered under this Contract, the Consultant shall be compensated for services performed in accordance with paragraph 1, not to exceed a sum of Three Hundred Seventy Thousand Ninety-Eight and 00/100 Dollars (\$370,098.00).

4. METHOD OF PAYMENT:

Payment will be made following completion of the terms set forth herein and receipt of an itemized invoice, certified under penalty of perjury, from the Consultant for services rendered in conformance with the Contract, and following approval by the Casper City Council. The invoice for payment must specify the correct amount due; that the Consultant has performed the services rendered under this Contract, in conformance with the Contract, and that it is entitled to receive the amount requested under the terms of the Contract.

If amounts owed by the Consultant to the City for any goods, services, licenses, permits or any other items or purpose remain unpaid beyond the City's general credit policy, those amounts may be deducted from the payment being made by the City to the Consultant pursuant to this Contract.

5. TERMS AND CONDITIONS:

This Contract is subject to and incorporates the provisions attached hereto as PART II -- GENERAL TERMS AND CONDITIONS.

6. EXTENT OF CONTRACT:

This Contract represents the entire and integrated Agreement between the City and the Consultant, and supersedes all prior negotiations, representations, or agreements, either written or oral. The Contract may be amended only by written instrument signed by both the City's and the Consultant's authorized representatives.

The City and the Consultant each individually represent that they have the requisite authority to execute this Contract and perform the services described in this Contract.

IN WITNESS WHEREOF, the undersigned duly authorized representatives of the parties have executed this Contract as of the day and year above.

APPROVED AS TO FORM

Walter Tremel H

ATTEST

CITY OF CASPER, WYOMING
A Municipal Corporation

Fleur Tremel
City Clerk

Ray Pacheco
Mayor

WITNESS

CONSULTANT
Worthington, Lenhart,
and Carpenter, Inc.

By: _____

By: _____

Printed Name: _____

Printed Name: _____

Title: _____

Title: _____

CONTRACT FOR PROFESSIONAL SERVICES

PART II - GENERAL TERMS AND CONDITIONS

1. TERMINATION OF CONTRACT:

1.1 The City may terminate this Contract anytime by providing thirty (30) days written notice to Consultant of intent to terminate said Contract. In such event, all finished or unfinished documents, data, studies and reports prepared by the Consultant under this Contract shall, at the option of the City, become its property, and the Consultant shall be entitled to receive just and equitable compensation for any satisfactory work completed on such documents.

1.2 Notwithstanding the above, the Consultant shall not be relieved of liability to the City for damages sustained by the City, by virtue of termination of the Contract by Consultant, or any breach of the Contract by the Consultant, and the City may withhold any payments to the Consultant for the purpose of setoff until such time as the exact amount of damages due the City from the Consultant are determined.

2. CHANGES:

The City may, from time to time, request changes in the scope of the services of the Contract. Such changes, including any increase or decrease in the amount of the Consultant's compensation, which are mutually agreed upon between the City and the Consultant, shall be incorporated in written amendments to this Contract. There shall be no increase in the amount of Consultant's compensation unless approved by Resolution adopted by City.

3. ASSIGNABILITY:

The Consultant shall not assign any interest in this Contract, and shall not transfer any interest in the same (whether by assignment or novation) without the prior written approval of the City: provided, however, that claims for money due or to become due to the Consultant from the City under this Contract may be assigned to a bank, trust company, or other financial institution, or to a trustee in bankruptcy, without such approval. Notice of any assignment or transfer shall be furnished to the City within five (5) business days of any assignment or transfer.

4. AUDIT:

The City and its representatives shall have access and obtain at its discretion, copies to any books, documents, papers, electronic data and records of the Consultant, which are pertinent to this Contract. The Consultant shall immediately, upon receiving written instruction from the City, provide to any independent auditor or accountant all books,

documents, papers, electronic data and recordings of the Consultant which are pertinent to this Contract. The Consultant shall cooperate fully with any such independent auditor or accountant during the entire course of any audit authorized by the City.

5. EQUAL EMPLOYMENT OPPORTUNITY:

In carrying out the program, the Consultant shall not discriminate against any employee or applicant for employment because of race, color, religion, sex, national origin, or disability. The Consultant shall take affirmative action to ensure that applicants for employment are employed, and that employees are treated during employment, without regard to their race, color, religion, sex, national origin, or disability. Such action shall include, but not be limited to, the following: employment upgrading, demotion, or transfer; recruitment or recruitment advertising; layoff or termination; rates of pay or other forms of compensation; and selection for training, including apprenticeship. The Consultant shall post in conspicuous places, available to employees and applicants for employment, notices required by the government setting forth the provisions of this nondiscrimination clause. The Consultant shall state that all qualified applicants will receive consideration for employment without regard to race, color, religion, sex, national origin, or disability.

6. OWNER OF PROJECT MATERIALS:

All finished or unfinished documents, data, studies, surveys, drawings, maps, models, photographs, films, duplicating plates, and reports prepared by the Consultant under this Contract shall be considered the property of the City, and upon completion of the services to be performed, or termination of this agreement, they will be turned over to the City provided that, in any case, the Consultant may, at no additional expense to the City, make and retain such additional copies thereof as Consultant desires for its own use; and provided further, that in no event may any of the documents, data, studies, surveys, drawings, maps, models, photographs, films, duplicating plates, or other reports retained by the Consultant be released to any person, agency, corporation, or organization without the written consent of the City.

7. FINDINGS CONFIDENTIAL:

All reports, information, data, etc., given to or prepared, or assembled by the Consultant under this Contract are confidential and shall not be made available to any individual or organization by the Consultant without the prior written consent of the City.

8. GOVERNING LAW AND VENUE:

This Contract shall be governed by the laws of the State of Wyoming. The Courts of the State of Wyoming shall have jurisdiction over this Contract and the parties. The venue shall be the Seventh Judicial District, Natrona County, Wyoming. The Consultant shall also comply with all applicable laws, ordinances, and codes of the local, state, or federal

governments and shall not trespass on any public or private property in performing any of the work embraced by this Contract.

9. PERSONNEL:

The Consultant represents that it has, or will secure, all personnel required in performing the services under this Contract. Such personnel shall not be employees of the City. All of the services required shall be performed by the Consultant, or under its supervision, and all personnel engaged in the work shall be fully qualified. All personnel employed by Consultant shall be employed in conformity with applicable local, state or federal laws.

10. SUBCONSULTANT:

The Consultant shall not employ any Subconsultant to perform any services in the scope of this project, unless the Subconsultant is approved in writing by the City. Any approved Subconsultant shall be paid by the Consultant.

11. INSURANCE AND INDEMNIFICATION:

A. **Prior to** the commencement of work, Consultant shall procure and maintain for the duration of the Contract insurance against claims for injuries to persons or damages to property which may arise from or in connection with the performance of the work hereunder by the Consultant, its Subconsultants, agents, representatives, or employees.

B. *Minimum Scope and limit of Insurance.*

Coverage shall be at least as broad as:

1. Commercial General Liability (CGL): Insurance Services Office Form CG 00 01 covering CGL on an "occurrence" basis, including products and completed operations, property damage, bodily injury and personal & advertising injury with limits no less than the sum of Two Hundred Fifty Thousand Dollars (\$250,000) to any claimant for any number of claims arising out of a single transaction or occurrence; or the sum of Five Hundred Thousand Dollars (\$500,000) for all claims arising out of a single transaction or occurrence. If a general aggregate limit applies, the general aggregate limit shall apply separately to this project/location (ISO CG 25 03 or 25 04) or the general aggregate limit shall be twice the required occurrence limit). The CGL policy shall be endorsed to contain Employers Liability/Stop Gap Coverage
2. Automobile Liability: Insurance Services Office Form Number CA 0001 covering Code 1 (any auto), or if Consultant has no owned autos, Code 8 (hired) and 9 (non-owned), with limit no less than Five Hundred Thousand (\$500,000) per accident for bodily injury and property damage.

3. Workers' Compensation: as required by the State of Wyoming with Statutory Limits.
4. Professional Liability (Errors and Omissions) Insurance appropriate to the Consultant's profession, with limit no less than the sum of Two Million Dollars (\$2,000,000) to any claimant for any number of claims arising out of a single transaction or occurrence; or the sum of Two Million Dollars (\$2,000,000) for all claims arising out of a single transaction or occurrence. If a general aggregate limit applies, the general aggregate limit shall apply separately to this project/location.

C. *Higher Limits.* If the Consultant maintains broader coverage and/or higher limits than required under this Agreement, then the City shall be entitled to the broader coverage and/or the higher limits maintained by the Consultant. Any available insurance proceeds in excess of the specified minimum limits of insurance and coverage shall be available to the City.

D. *Other Insurance Provisions*

The insurance policies are to contain, or be endorsed to contain, the following provisions:

1. *Additional Insured Status*

The City, its officers, elected and appointed officials, employees, agents and volunteers are to be covered as additional insureds on the CGL policy with respect to liability arising out of work or operations performed by or on behalf of the Consultant including materials, parts, or equipment furnished in connection with such work or operations. General liability coverage shall be provided in the form of an endorsement to the Consultant's insurance (at least as broad as ISO Form CG 20 10 11 85 or both CG 20 10, CG 20 26, CG 20 33, or CG 20 38 and CG 20 37 forms if later revisions used).

2. *Primary Coverage*

For any claims related to this Contract, the Consultant's insurance coverage shall be primary and non-contributory insurance coverage at least as broad as ISO CG 20 01 04 13 as respects the Consultant as respects the City, its officers, elected and appointed officials, employees, agents and volunteers.

3. *Notice of Cancellation*

Each insurance policy required above shall state that coverage shall not be canceled, materially changed, or reduced, except with notice to the City. Such notice to the City shall be provided in a commercially reasonable time.

4. *Waiver of Subrogation*

Consultant hereby grants to City a waiver of any right to subrogation which any insurer of said Consultant may acquire against the City by virtue of the payment of any loss under such insurance. Consultant agrees to obtain any endorsement that may be necessary to affect this waiver of subrogation, but this provision applies regardless of whether or not the City has received a waiver of subrogation endorsement from the insurer.

5. *Deductibles and Self-Insured Retentions*

Consultant has two options regarding deductibles and self-insured retentions:

- a. Option 1: Any deductibles or self-insured retentions must be declared to and approved by the City. Unless otherwise approved by the City in writing, any deductible may not exceed Ten Thousand Dollars (\$10,000). Unless otherwise approved in writing by the City, self-insured retentions may not exceed Ten Thousand Dollars (\$10,000), and the City may require the Consultant to provide proof of ability to pay losses and related investigations, claim administration, and defense expenses within the retention.
- b. Option 2: Consultant shall carry insurance with terms that require its insurance company to pay the full value of a covered claim from the first dollar of coverage, even if the Consultant is unable to pay any deductible or self-insured retention amount(s) required by the insurance policy. Consultant shall provide a written endorsement from its insurance carrier that such insurance coverage is in place, and shall keep such coverage in place during the term of this Contract and any subsequent time period required for claims made policies.

6. *Acceptability of Insurers*

Insurance is to be placed with insurers with a current A.M. Best's rating of no less than A:VII, unless otherwise agreed to in writing by the City.

7. *Claims Made Policies*

If any of the required policies provide coverage on a claims-made basis:

- a. The Retroactive Date must be shown and must be before the date of the Contract or the beginning of Contract work.
- b. Insurance must be maintained and evidence of insurance must be provided *for at least five (5) years after completion of the contract of work*. However,

Consultant's liabilities under this Contract shall not be deemed limited in any way by the insurance coverage required.

- c. If coverage is canceled or non-renewed, and not *replaced with another claims-made policy form with a Retroactive Date* prior to the Contract effective date, the Consultant must purchase "extended reporting" coverage for a minimum of *five (5)* years after completion of contract work and at all times thereafter until the applicable statute of limitations runs.

8. *Verification of Coverage*

Consultant shall furnish the City with original certificates of insurance including all required amendatory endorsements or copies of the applicable policy language effecting coverage required by this clause and a copy of the Declarations and Endorsement Page of the CGL policy listing all policy endorsements to the City before work begins. All certificates and endorsements are to be received and approved by the City before work commences. However, failure to obtain the required documents prior to the work beginning shall not waive the Consultant's obligation to provide them. The City reserves the right to require complete, certified copies of all required insurance policies, including endorsements required by these specifications, at any time.

9. *Subconsultants*

Consultant shall require and verify that all Subconsultants maintain insurance meeting all the requirements stated herein, and Consultant shall ensure that the City is an additional insured on insurance required from Subconsultants.

10. *Special Risks or Circumstances*

City reserves the right to reasonably modify these requirements, including limits, based on the nature of the risk, prior experience, insurer, coverage, or other special circumstances.

- E. Consultant agrees to indemnify the City, the City's employees, elected officials, appointed officials, agents, and volunteers, and all additional insured and hold them harmless from all liability for damages to property or injury to or death to persons, including all reasonable costs, expenses, and attorney's fees incurred related thereto, to the extent arising from negligence, fault or willful and wanton conduct of the Consultant and any Subconsultant thereof.

12. LIMITATION OF LIABILITY:

In no event shall the City, the City's employees, elected officials, appointed officials, or agents be liable under this Contract to Consultant or any third party for consequential, indirect, incidental, special, exemplary, punitive or enhanced damages or lost profits or revenues, or diminution in value, arising out of, relating to, or in connection with any

breach of this Contract, regardless of (a) whether such damages were foreseeable (b) whether or not the Consultant was advised of the possibility of such damages and (c) the legal or equitable theory (contract, tort, or otherwise) upon which the claim is based.

13. INTENT:

Consultant represents that it has read and agrees to the terms of this Contract and further agrees that it is the intent of the parties that Consultant shall perform all of the services for the compensation set forth in this Contract. Consultant also agrees that it is the specific intent of the parties, and a material condition of this Contract, that it shall not be entitled to compensation for other services rendered unless specifically authorized by the City by Resolution of its governing body. Consultant agrees that it has carefully examined the Scope of Services, and that the compensation is adequate for performance of this Contract.

14. WYOMING GOVERNMENTAL CLAIMS ACT:

The City does not waive any right or rights it may have pursuant to the Wyoming Governmental Claims Act, Wyoming Statutes Section 1-39-101 et seq., and the City specifically reserves the right to assert any and all rights, immunities, and defenses it may have pursuant to the Wyoming Governmental Claims Act.

15. NO THIRD PARTY BENEFICIARY RIGHTS:

The parties to this Contract do not intend to create in any other individual or entity the status of third-party beneficiary, and this Contract shall not be construed so as to create such status. The rights, duties and obligations contained in this Contract shall operate only between the parties to this Contract, and shall inure solely to the benefit of the parties to this Contract. The parties to this Contract intend and expressly agree that only parties signatory to this Contract shall have any legal or equitable right to seek to enforce this Contract, to seek any remedy arising out of a party's performance or failure to perform any term or condition of this Contract, or to bring an action for the breach of this Contract.

16. FORCE MAJEURE:

Neither party shall be liable for failure to perform under this Contract if such failure to perform arises out of causes beyond the control and without the fault or negligence of the nonperforming party. Such causes may include, but are not limited to, acts of God or the public enemy, fires, floods, epidemics, pandemics, quarantine restrictions, freight embargoes, and unusually severe weather. This provision shall become effective only if the party failing to perform immediately notifies the other party of the extent and nature of the problem, limits delay in performance to that required by the event, and takes all reasonable steps to minimize delays.

17. ELECTRONIC SIGNATURES:

The parties understand and agree that they have the right to execute this Contract through paper or through electronic signature technology, which is in compliance with Wyoming and federal law governing electronic signatures. The parties agree that to the extent they sign electronically, their electronic signature is the legally binding equivalent to their handwritten signature. Whenever they execute an electronic signature, it has the same validity and meaning as their handwritten signature. They will not, at any time in the future, repudiate the meaning of their electronic signature or claim that their electronic signature is not legally binding. They agree not to object to the admissibility of this Contract as an electronic record, or a paper copy of an electronic document, or a paper copy of a document bearing an electronic signature, on the grounds that it is an electronic record or electronic signature or that it is not in its original form or is not an original. Each party will immediately request that their electronic signature be revoked in writing if they discover or suspect that it has been or is in danger of being lost, disclosed, compromised or subjected to unauthorized use in any way. If either party would like a paper copy of this Contract, they may request a copy from the other party, and the other party shall provide it.

RESOLUTION NO. 22-188

A RESOLUTION AUTHORIZING A CONTRACT FOR PROFESSIONAL SERVICES WITH WORTHINGTON, LENHART, AND CARPENTER, INC., FOR PROFESSIONAL SERVICES FOR THE WESTRIDGE ADDITION IMPROVMENTS, PROJECT NO. 21-065.

WHEREAS, the City of Casper desires to secure an engineering firm to provide engineering design, establishing a Local Assessment District (LAD), bidding, and construction administration for the Westridge Addition Improvements project; and,

WHEREAS, Worthington, Lenhart, and Carpenter, Inc. (WLC) is able and willing to provide those professional services.

NOW, THEREFORE, BE IT RESOLVED BY THE GOVERNING BODY OF THE CITY OF CASPER, WYOMING: That the Mayor is hereby authorized and directed to execute, and the City Clerk to attest, a Contract for Professional Services with WLC in the amount of Three Hundred Seventy Thousand Ninety-Eight and 00/100 Dollars (\$370,098.00) for services more specifically delineated in the Contract.

BE IT FURTHER RESOLVED: That the City Manager is hereby authorized to make verified partial payments and contract extensions, using appropriate funds, throughout the project as prescribed by the Contract, for a total amount not to exceed Three Hundred Seventy Thousand Ninety-Eight and 00/100 Dollars (\$370,098.00).

PASSED, APPROVED, AND ADOPTED this ____ day of _____, 2022.

APPROVED AS TO FORM:



ATTEST:

Fleur Tremel
City Clerk

CITY OF CASPER, WYOMING
A Municipal Corporation

Ray Pacheco
Mayor

October 13, 2022

MEMO TO: City Council
J. Carter Napier, City Manager 

FROM: John Henley, City Attorney 

SUBJECT: A Resolution Ratifying and Approving a Lease Agreement between the City of Casper, Wyoming, a Wyoming municipal corporation and the Charles E. Piersall, Chapter of the Izaak Walton League of America

Meeting Type & Date:
Regular Council Meeting
October 18, 2022

Action type:
Resolution

Recommendation:
That Council approve a Resolution Ratifying and Approving a Lease Agreement between the City of Casper, Wyoming, a Wyoming municipal corporation and the Charles E. Piersall, Chapter of the Izaak Walton League of America.

Summary:
The City of Casper purchased property from the Charles E. Piersall, Chapter of the Izaak Walton League of America contingent upon the City of Casper leasing a portion of the property to the Chapter under the terms and conditions set out in a Lease Agreement between the parties.

Due to unforeseen circumstances, the closing and the sale of the property was delayed until August 26, 2022. The Lease Agreement was entered into on October 13, 2022, and the lease commencement date was changed to October 13, 2022, throughout the Agreement.

Staff is requesting the Governing Body to ratify and approve the Lease Agreement dated October 13, 2022, between the parties.

Financial Considerations:
None

Oversight/Project Responsibility
John Henley, City Attorney's Office

Attachments
Lease Agreement
Resolution

LEASE AGREEMENT

13th October SPC gfb

This LEASE AGREEMENT ("**Lease**"), dated as of the 13th day of October 2022 (the "**Effective Date**"), is entered into by and between the City of Casper, Wyoming, a Wyoming Municipal Corporation, 200 North David Street, Casper, Wyoming 82601 ("**Landlord**") and Charles E. Piersall, Chapter of the Izaak Walton League of America, a non-profit corporation, qualified to do business in the State of Wyoming, having an address of 4205 Fort Casper Road, Casper, Wyoming, 82604 ("**Tenant**").

This Lease Agreement is the last document of three, executed between Charles E. Piersall, Chapter of the Izaak Walton League of America ("IW"), and the City of Casper, Wyoming ("City"). The three documents are: the Deed of Perpetual Conservation Easement from IW to the City, a Purchase and Sale Agreement from IW to the City, and this Lease Agreement.

Landlord and Tenant are also sometimes referred to herein collectively as the "**Parties**" or individually as a "**Party**."

In consideration of the rents, covenants, and agreements hereinafter set forth, the sufficiency of which is hereby acknowledged and agreed, Landlord and Tenant covenant, warrant, and agree as follows:

1. Definitions

1.1 Defined Terms. For purposes of this Lease, the following terms shall have the following meanings:

"**Affiliate**" means for any entity, any parent, subsidiary or affiliate corporation which Controls, is Controlled by or is under common Control with such entity. For purposes of this definition, "**Control**" means the possession of the power to direct or cause the direction of the management and policy of an entity, whether through the ownership of voting securities, by statute, or by contract. The Parties have agreed not to assign their interest to or in the Leased Property, to an "affiliate" or any other entity, place or individual.

"**Alterations**" is defined in Section 10.1.

"**Assignment**" is defined in Section 14.1.

"**Buildings**" means the lodge and camp common areas identified on Exhibit A-1 and Exhibit A.

"**Building Systems**" means the structural portions of the building, the roof, the foundation, the HVAC Systems (as hereafter defined), mechanical, electrical, plumbing, security, and fire and life safety systems and equipment.

"**Business Days**" means all days, excluding the following days: Saturdays, Sundays, and all days observed as legal holidays by the State of Wyoming and the Federal Government.

"Business Hours" means, on each Business Day, the hours from 8:00 a.m. to 5:00 p.m. United States Mountain Time.

"Common Areas" means the entrances, lobby, accessways, hallways, camper lavatories, showers, stairways, and other building areas and the driveways, parking areas, and landscaped areas on the Property that are designated for the nonexclusive common use of tenant and its invitees.

"Tenant's Default" is defined in Section 15.

"Fixed Rent" is defined in Section 4.1.

"Force Majeure Event" means any of the following events: (a) acts of God; (b) floods, fires, earthquakes, explosions, or other natural disasters; (c) war, invasions, hostilities (whether war is declared or not), terrorist threats or acts, riots or other civil unrest; (d) governmental authority, proclamations, orders, laws, actions, or requests; (e) epidemics, pandemics, or other national or regional public health emergencies; (f) other similar events beyond the reasonable control of the Parties, which practically prevent one or both parties from fulfilling the terms of this Lease.

"Hazardous Materials" means any chemical, compound, material, substance, or other matter that: (a) is defined as a hazardous substance, hazardous material, or waste, or toxic substance under any Hazardous Materials Law; (b) is regulated, controlled, or governed by any Hazardous Materials Law or other laws; (c) is petroleum or a petroleum product; or (d) is asbestos, formaldehyde, radioactive material, drug, bacteria, virus, or other injurious or potentially injurious material (by itself or in combination with other materials).

"Hazardous Materials Law" means any federal, state, or local law, ordinance, rule, decree, order, regulation, or court decision relating to Hazardous Materials or other environmental conditions on, under, or about the Premises, the building, or the Property, or soil and ground water conditions, including, but not limited to, the Comprehensive Environmental Response, Compensation and Liability Act of 1980 (CERCLA), the Resource Conservation and Recovery Act (RCRA), the Hazardous Materials Transportation Act, any other law or legal requirement concerning hazardous or toxic substances, and any amendments to the foregoing.

"HVAC" means heating, ventilation, and air-conditioning.

"HVAC Systems" means the HVAC systems of the building.

"Landlord Party" means Landlord's offices, agents, employees and City Council Members or its representatives.

"Landlord's Address for Notices" means City of Casper, City Hall Attention: City Manager with a copy to the City Attorney, 200 North David Street,

Casper, Wyoming 82601, or at such other address as Landlord shall designate by written notice to Tenant sent pursuant to Section 19 hereof.

"Landlord's Address for Rent Payments" means

City of Casper, Wyoming
Attn: Financial Services
200 North David Street
Casper, WY 82601

"Laws" is defined in Section 8.3.

"Lease Commencement Date" is ~~June 8, 2022~~.

October 13, 2022
JPC
JSB

"Leased Premises" means legal description for parcel 1(campground) and the legal description of a portion of parcel 2 as described on Exhibit A-1 hereto. Landlord and Tenant hereby agree that the Premises contains approximately 19.31 acres.

"Minor Alterations" is defined in Section 10.2.

"Mortgagee" means any mortgagee or beneficiary under any current or future Mortgage affecting the Property.

"Operating Expenses" is defined in Section 5.1(a).

"Operating Year" is the calendar year.

"Party" or **"Parties"** is defined in the Preamble.

"Permitted Use" are uses permitted in the Lease between the grantee and grantor which is contemplated to be completed, subsequent to purchase of the Property by the City of Casper. The uses are constrained by the conservation easement.

"Property" means the real property on which the lodge building and campground spaces and common areas are located together with the building and all appurtenant fixtures and personal property of Landlord used in the operation of the building and/or the Property, and any other improvements now existing, including the roads, parking lot, and walkways as depicted on the survey attached hereto as Exhibit A-1 (consisting of approximately 11.94 acres) and Exhibit A (consisting of approximately 7.93 acres).

"Restoration Estimate" is defined in Section 13.1.

"Tax" or "Taxes" are any taxes assessed by the Natrona County Treasurer for the operation of the Tenant's businesses on the Leased Property.

"Tenant Parties/Party" means Tenant and its officers, directors and agents.

"Tenant-Owned Property" is the personal property of Tenant; it includes all personal property not listed in Personal Property Exhibit B.

"Tenant's Address for Notices" means 4205 Ft. Caspar Rd, Casper, WY 82604, Attention: President of the Board of Directors, or at such other address: or as tenant shall designate by written notice to Landlord sent pursuant to Section 19 hereof.

1.2 Interpretation.

(a) This Lease shall be construed without regard to any presumption or other rule requiring construction against the drafting Party.

(b) The captions, headings, and titles in this Lease are solely for convenience of reference and shall not affect the interpretation of the provisions under such caption, heading, or title.

(c) Words of any gender used in this Lease shall be held and construed to include any other gender, and words in the singular number shall be held to include the plural, unless the context otherwise requires.

(d) As used in this Lease: (i) "and/or" when applied to one or more matters or things applies to any one or more, or all such matters or things as the circumstances warrant; (ii) "including" means "including, without limitation"; (iii) "person" means any natural person or persons, a partnership, a corporation, and any other form of business or legal association or entity; and (iv) "this Lease," "herein," "hereof," and "hereunder," and words of similar import, refer to this Lease as a whole, and not to any particular section, unless expressly so stated.

(e) All of the terms and provisions of each exhibit to this Lease are incorporated into and made a part of this Lease to the same extent as if they were included in the body of this Lease.

2. Lease of Premises

2.1 Demise. Landlord hereby leases to Tenant, and Tenant hereby rents from Landlord the Leased Premises for the Term, upon and subject to the terms, covenants, representations, warranties, provisions, and conditions of this Lease. The Leased Premises are accepted "as is" except Landlord has agreed to upgrade the Leased Premises as referenced in Section 3.1 (a).

2.2 Common Areas. Tenant and Landlord shall have the nonexclusive right to use the Common Areas of the Premises.

3. Term. This Lease shall be effective and binding on Landlord and Tenant on 8th day of June, 2022. The Lease terms are provided in Section 3.1.

3.1 The term and basic terms of this Lease are:

Landlord/City shall pursuant to the Purchase Agreement between the parties, provide upgrades to the Leased Premises:

(a) Landlord/City will complete, within 24 months from the date of closing needed electrical upgrades for the campground and its service buildings; install the new water main line; install in the established campground individual RV space water lines; and complete required repairs identified in the Property inspection including lodge repairs (see Exhibit C), in addition, the City shall complete restoration of the lodge exterior walls.

(b) Landlord/City shall use its best efforts to assist the Tenant/Charles E. Piersall Chapter, Izaak Walton League of America in obtaining Historical Registry of the lodge.

(c) The Parties shall share equally the in the cost to make higher cost repairs of those over Fifteen Thousand Dollars (\$15,000.00), to the lodge and campground, except for the updates which are Landlord/City's responsibility as set forth in Purchase and Sale Agreement and referenced in paragraph (a) above.

3.2 Property "as is". Tenant takes the Property "as is" but with the agreement of landlord as stated in the Purchase Agreement between the Parties.

4. Rent

4.1 Fixed Rent. Tenant shall pay to Landlord a fixed rent ("**Fixed Rent**") at the rate of:

Time Period	Annual Fixed Rent	Monthly Fixed Rent
JBC Lease Commencement Date to (Five years from the date of Sale May 25, 2022. Lease commencement date (10-13-2022 to 10-13-2027)	\$1.00	See annual fixed rate.
JBC First Extension of Term Years ⁶ 8-10 from the date of sale ^H Lease commencement date 10-13-2022 (10-13-2027 - 10-13-2032)	\$24,000.00	\$2,000.00
JBC Second Extension Term Years 10-15 from the date of sale. Lease commencement date 10-13-2022 (10-13-2032 - 10-13-2037)	\$42,000.00	\$3,500.00
After fifteen years, the Tenant will be required to negotiate with the Casper City Council and Casper City Manager, for any additional lease of Leased Premises.		

4.2 Additional Rent. In addition to Fixed Rent, Tenant shall pay to Landlord taxes for the Leased Premises if as assessed by Natrona County, Wyoming.

4.3 Rent Payments. Fixed Rent shall be payable commencing on the Lease Commencement Date and thereafter fixed rent payments in advance on the first day of each and every calendar month during the term of this Lease. Taxes shall be payable no later than the due dates established by Natrona County. Tenant agrees to pay Fixed Rent, and Property taxes, if any, promptly when due without notice or Landlord's demand. All items of Rent shall be paid without any abatement, deduction, or setoff for any reason whatsoever. Tenant's covenant to pay Rent (both fixed and additional, if imposed) is independent of every other covenant in this Lease.

4.4 Interest on Late Rental Payments. Tenant shall also pay interest on unpaid sums herein at five percent (5%) compounded annually, without further notice or demand therefor by Landlord. The "Default Rate" means an annual rate equal to five percent (5%) of past due obligations compounded annually. Interest will accrue from the date that the unpaid sums were payable under this Lease until actually paid by Tenant.

5. Operating Expenses

5.1 Operating Expense Definitions. Tenant is responsible for and shall pay as billed:

(a) **"Operating Expenses"** means all costs and expenses paid or incurred in connection with the management, operation, maintenance, repair and/or replacement of the Leased Premises except to the specific exceptions herein.

(i) In particular, Operating Expenses shall include the cost of:

(A) Maintenance for and updates to the business Property (including Camper/RV hookups and connections.

(B) Utilities, water, and sewage services for the Property.

(C) Maintenance of signs.

(D) Insurance premiums (including liability, workers' compensation, casualty, general and special perils, and flood insurance) and deductibles. (See section 11. Insurance, for detail(s))

(E) Fees for licenses and permits.

(F) General maintenance services and upgrades to the Common Areas.

(G) Window washing.

(H) Exterior and interior painting of the business structures and the Common Areas.

(I) Janitorial cleaning and refuse removal services.

(J) Security costs, including security access control systems and security personnel (if any).

(K) Personnel costs applicable to the building and the Property, including wages and salaries, fringe benefits, and payroll taxes.

(L) Any management fee for the professional operation of the Property.

(M) Other fees and costs associated with the operation of the businesses and operations of the Tenant.

6. Utilities and Services From and after the Lease Commencement Date and thereafter throughout the Term, Tenant agrees to furnish the Premises with the utilities and services, cost to maintain and operate its business (campground and lodge).

6.1 Bulbs and Ballasts. Tenant shall provide, install, and replace all necessary ballasts, light bulbs, and tubes.

6.2 Telecommunications. With respect to Tenant's telecommunications facilities and services, Tenant shall select the providers and make arrangements directly with all providers of Tenant's telecommunications (telecom) facilities and services and pay for services provided by it to Tenant pursuant to a separate agreement between Tenant and the service provider. Tenant and Tenant's telecom service provider shall have reasonable use of telephone or data closets, risers, shafts, conduits, or other facilities in and on the Premises and buildings, to bring such telecom services to the desired portions of the Premises.

6.3 Service Interruptions. Landlord shall not be liable to Tenant in any respect for the inadequacy, stoppage, interruption, or discontinuance of any utility or service other than as may be claimed under the Wyoming Governmental Claims Act W.S. § 1-39-101 et seq.

7. Occupancy

7.1 As-Is. Tenant agrees that Tenant is familiar with the condition of both the Premises and the buildings, and, except as for upgrades expressly and specifically set forth herein, accepts the Premises in its "AS-IS, WHERE-IS" condition. Tenant acknowledges that neither Landlord, nor any representative of Landlord, has made any representation as to the condition of the Premises or its suitability for Tenant's intended use other than as expressly set forth herein. Tenant acknowledges and agrees that Tenant has made its own inspection of the Premises and except as otherwise expressly and specifically described

herein, Landlord has no obligation to make any repairs, replacements, or improvements other than expressly set forth herein.

8. Use of Premises; Compliance with Laws; Hazardous Materials

8.1 Use. The Leased Premises shall be used only for the uses of the campground, its facilities, chapter activities as engaged in currently, including a contemplated archery range and lodge.

8.2 Legal and Other Restrictions of Tenant's Use. Use of the Premises is subject to all covenants, conditions, and restrictions of record. Tenant shall not use or occupy the Premises: (a) for any unlawful purpose; (b) in any way that will violate the certificate of occupancy for the Premises or the building; (c) in a way that will constitute waste, nuisance, or unreasonable annoyance to Landlord; or (d) in a way that may increase the cost of, or invalidate, any policy of insurance carried on the buildings.

8.3 Compliance with Laws. Tenant, at Tenant's sole cost and expense, shall comply with (and shall cause all Tenant Parties to comply with) all Laws applicable to the Premises or the use or occupancy of the Premises. "Laws" means all present and future laws, local, state, and federal, (including federal and state civil rights and anti-discrimination laws and the Americans with Disabilities Act of 1990, as amended by the Americans with Disabilities Act Amendments Act of 2008, and the regulations promulgated pursuant to such acts), ordinances (including zoning ordinances and land use requirements), rules, and regulations of governmental and quasi-governmental authorities. If any such Laws require an occupancy or use permit or license for the Premises or the operation of the business conducted therein (including a certificate of occupancy or nonresidential use permit), then Tenant shall obtain and keep current such permit or license at Tenant's sole cost and expense and shall promptly deliver a copy thereof to Landlord. Nothing in this Section 8.3, however, shall permit Tenant to make, without Landlord's prior written approval, any Alterations to the Premises which otherwise would require Landlord's approval under this Lease, and Tenant shall comply with all of the requirements of this Lease in making any such Alterations.

8.4 Hazardous Materials. Tenant shall not cause or permit any Hazardous Materials to be generated, used, released, stored, or disposed of in or about the Premises, the building, or the Property. Tenant, however, may use and store reasonable quantities of cleaning and office supplies and other similar materials as may be reasonably necessary for Tenant to conduct normal business operations in the Premises. From and after the Effective Date, Tenant shall indemnify and hold the Landlord Parties, harmless from and against any damage, injury, loss, liability, charge, demand, or claim based on or arising out of the presence or removal of, or failure to remove, Hazardous Materials generated, used, released, stored, or disposed of by Tenant or any Tenant Party in or about the Premises, the building, or the Property. In no event shall Landlord be liable for Hazardous Material generated, used, released, stored, or disposed of by Tenant or any Tenant Party, or any other tenant or invitee of the Property. The terms of this Section shall survive the expiration or earlier termination of this Lease.

9. Maintenance and/or Repairs

9.1 Joint Maintenance and Repair Obligations. The Parties shall share equally the in the cost to make non-routine more expensive repairs, over Fifteen Thousand Dollars (\$15,000.00), to the lodge and campground, except for updates which are landlord's responsibilities as set forth in paragraph 3.1 (a), herein.

9.2 Tenant's Maintenance and Repair Obligations. Throughout the Term, Tenant, at Tenant's expense, shall repair, replace, and maintain in good condition all portions of the Premises, including entries, doors, ceilings, glass partitions, and interior walls. Any repairs or maintenance shall be completed with materials of similar quality to the original materials. Maintenance may be performed by Tenant, repairs shall be performed by licensed contractors, or such other contractors approved in writing by Landlord. If Tenant fails to maintain or repair the Premises in accordance with this Section (9), Landlord may, in its sole discretion and upon thirty (30) days prior notice to Tenant (except no advance notice shall be required in the case of emergencies), perform such repairs and maintenance. Tenant shall pay to Landlord all costs or expenses incurred by Landlord to perform such maintenance within thirty (30) days after written demand.

10. Alterations

10.1 Tenant Alterations. Tenant shall not make or allow to be made any alterations, additions, or improvements in or to the Premises (collectively, "Alterations") without the prior written consent of Landlord, which consent may be granted or denied in Landlord's reasonable discretion.

10.2 Minor Alterations. Notwithstanding Section 11.1, Tenant may make Minor Alterations to the Premises without Landlord's prior consent. "Minor Alterations" means decorative and other minor Alterations that: (a) do not affect the building Systems or change the configuration of the Premises by removing or erecting interior walls; and (b) cost no more than Five Thousand Dollars (\$5,000.00) in any one instance, and, in the aggregate, do not exceed Ten Thousand Dollars (\$10,000.00) in any calendar year.

10.3 Performance by Tenant. Tenant agrees that all Alterations shall be performed and completed: (a) at Tenant's sole cost and expense; (b) in accordance with plans and specifications provided to Landlord at least thirty (30) days prior to the commencement of such work (and approved by Landlord if Landlord's approval is required); and (c) in a good and workmanlike manner by contractors licensed by the City of Casper, Wyoming. The performance and completion of any such Alteration shall not impair the structural integrity of the building or adversely affect the buildings or axillary structures on the Leased Premises. Tenant shall not permit any liens to attach to any part of the Leased Premises, the buildings, or the Premises arising out of the Alteration. Tenant shall obtain, at its sole expense, all permits required for such Alterations. Throughout the performance of Alterations, Tenant, at its expense, shall carry the additional insurance required by Sections 11.1(d).

10.4 Ownership of Alterations. Unless Landlord elects otherwise, all Alterations made by Tenant shall become the property of Landlord and shall be surrendered to Landlord upon the Lease's conclusion.

11. Insurance

11.1 Tenant Insurance. At all times during the term of this Lease, Tenant, at Tenant's expense, shall maintain at its sole cost and expense, the following insurance policies in accordance with this Section 11:

(a) "All-risk" or "special perils" property insurance covering physical loss or damage insuring the full replacement value of all present and future buildings, structures, alterations, leasehold improvements, and all items of Tenant and Landlord Owned Property to a limit of not less than the full replacement value thereof.

(b) Commercial general liability insurance in respect of the Premises and the conduct or operation of business therein with a minimum combined single limit of liability of Three Million Dollars (\$3,000,000.00). Such liability insurance shall include products and completed operations liability insurance, fire, and legal liability insurance, and such other coverage as Landlord may reasonably require from time to time.

(c) Workers' compensation insurance providing coverage as required by the State of Wyoming, and employer's liability insurance with a minimum limit of Five Hundred Thousand Dollars (\$500,000.00) covering all of Tenant's employees.

(d) At all times when Alterations are in progress, Tenant, at its expense, shall maintain, or cause to be maintained, all risk property and/or Builders Risk insurance and general liability insurance, with completed operation endorsement, for any occurrence in or about the building. Tenant shall furnish Landlord with reasonably satisfactory evidence that such insurance is in effect at or before the commencement of Alterations and, on request, at reasonable intervals thereafter during the continuance of Alterations.

(e) Flood insurance, if the Leased Premises is in a flood plain.

11.2 Policy Requirements.

(a) Tenant's insurance shall be issued by companies approved by Landlord in its reasonable discretion and authorized to do business in the State of Wyoming with a current A.M. Best's rating of no less than A:VII and rated in Best's Insurance and a "Financial Size Category" of at least or better or, if such ratings are not then in effect, the equivalent thereof or such other financial rating as Landlord may at any time consider appropriate]. [Tenant shall have the right to provide insurance coverage pursuant to blanket policies obtained by Tenant if the blanket policies expressly afford the coverages required by this Section 11.]

(b) All insurance policies required to be carried by Tenant under this Lease (except for workers' compensation insurance) shall: (i) name Landlord, its City Council, officers, agents and employees and any parties designated by Landlord, as additional insureds; (ii) as to liability coverages, be written on an "occurrence" basis; and (iii) provide that Landlord shall receive sixty (60) days' notice from the insurer before any cancellation or change in coverage.

(c) Each such policy shall contain a provision that such policy and the coverage evidenced thereby shall be primary and non-contributing with respect to any policies carried by Landlord. Tenant shall deliver evidence of insurance satisfactory to Landlord in its reasonable discretion; to Landlord effective on the commencement date of this agreement and thereafter at least Sixty (60) days before the expiration dates of expiring policies.

(d) If Tenant fails to maintain such insurance in accordance with the terms hereof, Landlord shall have the right, but not the obligation, to procure any such insurance for the account of Tenant, immediately and without notice to Tenant, and the cost thereof shall be paid by Tenant to Landlord. The limits of the insurance required under this Lease shall not limit Tenant's liability. During the Term, at Landlord's request, Tenant shall increase such insurance coverage to a level that is commercially reasonably required by Landlord.

11.3 Non-Liability. Unless caused by Landlord's intentional misconduct, Landlord shall not be liable for damage of any nature to any person, to the Premises, or to Tenant's personal property or equipment, including the Tenant-Owned Property, caused by explosion, fire, theft, breakage, vandalism, falling plaster, building System failure, steam, gas, electricity, water, rain, or other substances leaking, emanating from, or flowing into any part of the Premises, or from damage caused by any other tenant of the building, it being agreed that Tenant is responsible for obtaining appropriate insurance to protect the parties' interests.

11.4 Wyoming Governmental Claims Act. The Landlord/City does not waive any right or rights it may have pursuant to the Wyoming Governmental Claims Act, Wyoming Statutes Section 1-39-101 et seq., and the Landlord/City specifically reserves the right to assert any and all rights, immunities, and defenses it may have pursuant to the Wyoming Governmental Claims Act.

11.5 Waiver of Subrogation. Tenant waives and agrees to obtain a waiver from its insurance company of their respective right of recovery against the Landlord for any direct, indirect or consequential damage to the Property of the Tenant by fire or other casualty to the extent such damage is or should as, provided herein, be insured against under a policy or policies of insurance. Tenant shall cause its insurance policies to be endorsed to evidence compliance with such waiver.

12. Indemnification

12.1 Indemnity of Landlord. Except to the extent resulting from the willful misconduct of Landlord or any Landlord Party, Tenant shall indemnify, defend, and hold Landlord harmless from and against any and all claims, losses, costs, liabilities, damages, and expenses, including penalties, fines, and reasonable attorneys' fees, incurred in connection with or arising directly or indirectly from: (a) any breach or default by Tenant in the performance of any of its obligations under this Lease; (b) any injury or death to persons or damage to property occurring within or about the Premises; or (c) the use or occupancy of the Premises by Tenant, any Tenant Parties, or any person occupying the Premises through Tenant.

12.2 Survival. The terms of this Section (12) shall survive the expiration or earlier termination of this Lease.

13. Damage and Destruction

13.1 Restoration. Tenant shall promptly notify Landlord of any damage to the Premises resulting from fire or any other casualty. If the Leased Premises or the Common Areas are destroyed or damaged by fire or other casualty so that Tenant is unable to occupy the Premises for its Permitted Use, then within Ninety (90) days after that event, Landlord shall give Tenant a notice specifying the estimated time, in Landlord's reasonable judgment, required for repair or restoration (the "**Restoration Estimate**"). If either (i) the Restoration Estimate is One Hundred and Eighty (180) days or less, or (ii) the Restoration Estimate exceeds One Hundred and Eighty (180) days and Landlord does not elect to terminate this Lease in accordance with Section 13.2 hereof, then Landlord shall proceed promptly to the extent of the available insurance proceeds, to have repaired or restored the Leased Premises provided, however, Landlord shall not be obligated repair or restore any Tenant Alterations and/or Tenant-Owned Property. Provided this Lease is not terminated pursuant to Section 13.2, this Lease shall remain in full force, except that Rent shall abate in accordance with Section 13.3.

13.2 Termination Rights. If the Restoration Estimate exceeds One Hundred and Eighty (180) days, then Landlord may elect to terminate this Lease by giving a termination notice to Tenant within Ninety (90) days following delivery of the Restoration Estimate, in which event this Lease shall cease and terminate as of the date of such termination notice. If the casualty occurs during the last Forty-Eight (48) months of the second extension, then either Landlord or Tenant may elect to terminate this Lease, by giving a termination notice to the other within Thirty (30) days following delivery of the Restoration Estimate, in which event this Lease shall cease and terminate as of the date of such termination notice.

13.3 Rent Abatement. If the damage or destruction renders all or part of the Leased Premises untenantable, Rent shall proportionately abate commencing on the date of the damage or destruction and ending on the date the Leased Premises are delivered to Tenant with the restoration substantially completed. The extent of the abatement shall be based upon the portion of the Leased Premises rendered untenantable.

14. Assignment and Subletting

14.1 Landlord Consent Required. Except for the rental of its camping spaces, Tenant shall not sublease the Leased Premises directly or indirectly, voluntarily or by operation of law. The parties expressly agree that their relationship to the Premises is unique and the only entity with which the City will lease the Premises is the Tenant. The Tenant receives favorable terms and the Landlord has agreed herein agree to smaller (less than fair market value) rent payments for the Leased Premises. In addition, except for the rental of its camping spaces, the Tenant shall not mortgage, pledge, assign, or otherwise encumber its interest in this Lease or in the Premises. An "Assignment" means any sale, assignment, or other transfer of all or any part of the Premises or Tenant's leasehold estate hereunder. An assignment of subleased by the Tenant except for short-term lodge or camp space use shall be void.

15. Tenant's Default Each of the following events shall be an "Event of Default" hereunder:

15.1 Monetary Default. Tenant fails to pay when due any installment of Rent and such failure continues for a period of Thirty (30) days after the due date.

15.2 Nonmonetary Default. Tenant fails to perform or observe any other covenant, condition, or obligation of Tenant, and such failure continues for a period of Fifteen (15) days after Landlord gives Tenant written notice thereof. Notwithstanding the foregoing, if a cure cannot be effected within such Fifteen (15) day period and provided that Tenant promptly begins and diligently pursues the cure in good faith during the Fifteen (15) day period, Tenant shall have such additional time as is reasonably necessary, not to exceed Thirty (30) additional days, Forty-Five (45) in the aggregate, to effect such cure.

15.3 Abandonment. Fifty percent or greater of the Leased Premises become vacant and abandoned (other than in connection with a casualty under Section 13) or Tenant fails to accept a tender of possession of the Leased Premises for more than four (4) weeks from the Lease Commencement Date.

15.4 Tenant Debtor Protections. The occurrence of any of the following:

(a) Tenant: (i) makes an assignment for the benefit of creditors; (ii) admits in writing its inability to pay its debts as they become due; or (iii) files a voluntary petition in bankruptcy.

(b) A proceeding or case is commenced against Tenant, in any court of competent jurisdiction seeks: (i) the appointment of a receiver to take possession of all or substantially all of the assets of Tenant; (ii) the attachment, execution, or other judicial seizure of all or substantially all of Tenant's assets; or (iii) reorganization, arrangement, composition, readjustment, liquidation, or dissolution of Tenant, or similar relief.

16. Landlord's Remedies Upon the occurrence of an Event of Default by Tenant, Landlord shall have all of the following rights and remedies in addition to all other rights and remedies available to Landlord at law or in equity:

16.1 Termination. The right to terminate Tenant's right to possession of the Leased Premises and to recover: (a) all Rent, interest and cost which shall have accrued and remains unpaid through the date of termination; plus (b) any other amount necessary to compensate Landlord for all the damages caused by Tenant's failure to perform its obligations under this Lease, including reasonable attorneys' and accountants' fees, costs of alterations of the Premises, interest costs, and back taxes, fines or obligations because of Tenants acts or omissions.

16.2 Removal. The right and power to enter the Leased Premises and remove therefrom all persons and property, to store such property in a public warehouse or elsewhere at the cost of and for the account of Tenant, and to sell such property and apply the proceeds therefrom pursuant to applicable law.

16.3 Appointment of Receiver. The right to have a receiver appointed for Tenant, upon application by Landlord, to take possession of the Premises, to apply any rental collected from the Leased Premises and to exercise all other rights and remedies granted to Landlord pursuant to this Lease Agreement.

16.4 Legal and Equitable Remedies. The right to specific performance of any or all of Tenant's obligations under this Lease and to damages for delay in or failure of such performance.

17. End of Term; Holding Over

17.1 Condition on Surrender. On the Lease Expiration Date, Tenant shall quit and surrender the Leased Premises to Landlord. The Leased Premises shall be surrendered to Landlord vacant, "broom-clean," and in good order, condition, and repair, normal wear and tear excepted. Tenant shall remove all of Tenant's equipment and personal property, all telecommunications equipment and wires and cables installed by or on behalf of Tenant, all Tenant-Owned Property, and all Alterations that Tenant is required to remove in accordance with Section 11. Tenant shall repair any damage to the Leased Premises, including any damage caused by such removal. If Tenant fails to repair any damage caused by the removal of any Alterations, Tenant shall reimburse Landlord for all costs and expenses incurred by Landlord in making any repairs and replacements to the Leased Premises. Any property (including Tenant-Owned Property) not removed by Tenant shall be deemed abandoned and, if Landlord so elects, deemed to be Landlord's property, and may be retained or removed and disposed of by Landlord in such manner as Landlord shall determine. Tenant shall reimburse Landlord for all costs and expenses, incurred by Landlord in effecting such removal and disposal. The provisions of this Section (17) shall survive the expiration or earlier termination of this Lease.

17.2 Holdover. No holding over by Tenant after the expiration or other termination of this Lease shall operate to extend the Term. Any holding over with Landlord's written consent shall be construed as a tenancy at sufferance or from month to month, at Landlord's option. If Tenant holds over, then: (a) Tenant shall pay Three Thousand Five Hundred Dollars (\$3,500.00) to Landlord for each month and a pro-rata amount for each portion of any month during which Tenant holds over in all or any portion of the Leased Premises, and

all items of Additional Rent, fees or charges under this Lease payable; (b) Tenant's occupancy shall otherwise be on the terms and conditions of this Lease so far as applicable (but expressly excluding all extension rights); and (c) Tenant shall indemnify, defend, and hold Landlord harmless from all losses, costs (including reasonable attorneys' fees), and liabilities resulting from such failure, including any claims made by any campers of Tenant founded upon such holdover. The acceptance by Landlord of any holdover rent shall not preclude Landlord from exercising any other rights under this Lease or at law, including Landlord's rights and remedies provided by law or this Lease.

18. Signs Tenant shall be permitted to install, at its own expense, signs containing Tenant's name at the entrance to the Premises or the lodge and in the reception area(s) of the Premises.

19. Notices All notices or other communications required hereunder shall be in writing and shall be deemed duly given: (a) when delivered in person (with a written receipt therefor); (b) on the next business day after deposit with a recognized overnight delivery service; or (c) on the third (3rd) business day after being sent by certified or registered mail, return receipt requested, postage prepaid, to Landlord's Address for Notices or to Tenant's Address for Notices, (Charles E. Piersall Chapter, Izaak Walton League of America, Attn: Chapter President, 4205 Ft. Caspar Rd, Casper, WY 82604) as applicable. After the Lease Commencement Date, all notices to Tenant may, at Landlord's option, be sent to the Leased Premises. Either Party may change its address for the giving of notices by notice given in accordance with this Section. A Party's refusal to accept delivery of any notice or communication sent by the other Party shall not render such notice ineffective. Notwithstanding the foregoing, all bills, statements, invoices, consents, requests, or other communications from Landlord to Tenant with respect to Rent may be sent to Tenant by regular United States mail.

20. Miscellaneous Provisions

20.1 Landlord Access. Landlord, and applicable Landlord Parties, shall have the right to enter the Premises, at all reasonable hours (and at any time in the event of an emergency) to: (a) inspect the Premises; (b) supply any service to the Premises; (c) post notices of non-responsibility; (d) determine whether Tenant is complying with its obligations under this Lease.

20.2 Successors. The terms, covenants, and conditions contained in this Lease shall bind and inure to the benefit of Landlord and Tenant.

20.3 Force Majeure.

(a) Neither Party shall be liable or responsible to the other Party, nor be deemed to have defaulted under or breached this Lease, for any failure or delay in fulfilling or performing any obligation under this Lease [(except for any obligations to make payments to the other Party hereunder)], when and to the extent such failure or delay is caused by a Force Majeure Event. The failure or inability of either Party to perform its obligations in this Lease due to a Force Majeure Event shall be excused for the duration of the Force Majeure Event and extended for a period equivalent to the

period of such delay, but not in excess of one hundred and twenty (120) days in the aggregate.

(b) Either Party (the "**Force Majeure Noticing Party**") shall give the other Party notice within fifteen (15) days of the commencement of the Force Majeure Event, explaining the nature or cause of the delay and stating the period of time the delay is expected to continue. The Force Majeure Noticing Party shall use diligent efforts to end the failure or delay and ensure the effects of such Force Majeure Event are minimized. The Force Majeure Noticing Party shall resume the performance of its obligations as soon as reasonably practicable after the Force Majeure Event ends.

20.4 Partial Invalidity. Each provision of this Lease shall be valid and enforceable to the fullest extent permitted by law. If any provision of this Lease or the application thereof to any person or circumstance shall, to any extent, be invalid or unenforceable, the remainder of this Lease, or the application of such provision to persons or circumstances other than those as to which it is invalid or unenforceable, shall not be affected thereby, and each provision of this Lease shall remain in effect and shall be enforceable to the full extent permitted by law.

20.5 Entire Agreement. This Lease (including all Exhibits) is intended as a final expression of the Parties' agreement regarding the Leased Premises, and may not be contradicted by evidence of any prior written or oral agreement. The Parties further intend that this Lease constitutes the complete and exclusive statement of its terms, and that no extrinsic evidence other than the Parties Purchase and Sale Agreement for the sale of the Tenant's property to Landlord, just prior to this Lease, may be introduced in any judicial or other proceeding, if any, involving this Lease.

20.6 No Representations. Neither Landlord nor Landlord's agents have made any representations or warranties with respect to the Premises, the building, the Property, or this Lease except as expressly set forth herein.

20.7 Governing Law; Consent to Jurisdiction and Venue. This Lease shall be governed by the laws of the State of Wyoming, which shall govern the validity, performance, and enforcement of this Lease. Tenant consents to personal jurisdiction and venue in the state of Wyoming, County of Natrona, Seventh Judicial District shall have exclusive jurisdiction and Tenant hereby agrees to such exclusive jurisdiction.

20.8 Amendments. This Lease may only be amended, modified, or supplemented by an agreement in writing duly executed by both Landlord and Tenant.

20.9 No Recording. Neither this Lease nor any memorandum hereof shall be recorded or filed in any land records or other public records of any jurisdiction.

[SIGNATURE PAGE FOLLOWS]

IN WITNESS WHEREOF, the Parties have executed this Lease as of the Effective Date.

Approved as to Form:

John Henley, City Attorney

ATTEST:

LANDLORD
CITY OF CASPER, WYOMING,
A Municipal Corporation:

City Clerk

By: _____
Ray Pacheco
Mayor

TENANT
CHARLES E. PIERSALL CHAPTER OF THE
IZAAK WALTON LEAGUE OF AMERICA

Brian Connelly
Brian Connelly, President, Charles E. Piersall Chapter
Printed Name and Title *IWLA.*

Jon E. Brady
Jon E. Brady, Secretary, Charles E. Piersall Chapter
IWLA

STATE OF WYOMING)
) ss.
COUNTY OF NATRONA)

The foregoing Lease Agreement was acknowledged before me on the 13 day of October, 2022, by Jon Grady, Secretary as the President of the Charles E. Piersall Chapter of the Izaak Walton League of America, as the "Tenant"

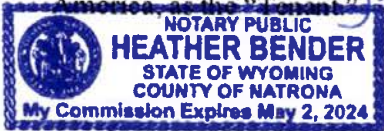

[Signature]
Notary Public

My Commission Expires: May 2, 2024

STATE OF WYOMING)
) ss.
COUNTY OF NATRONA)

The above and foregoing Lease Agreement was acknowledged before me on the ____ day of _____, 2022, by Ray Pacheco, as the Mayor of the City of Casper, Wyoming, a Wyoming Municipal Corporation, as the "Landlord"

Notary Public

My Commission Expires: _____

EXHIBIT A-1 "LEASED PREMISES"



EXHIBIT "A-1"
Portion of the Lot 3 (NW¼SW¼)
Section 7, T.33N., R.79W., &
NE¼SE¼ Section 12, T.33N., R.80W., 6th P.M.
Natrona County, Wyoming

A parcel of land situate within portions of Lot 3 (NW¼SW¼) of Section 7, T.33N., R.79W., 6th P.M., and the NE¼SE¼ of Section 12, T.33N., R.80W., 6th P.M., Natrona County, Wyoming, as shown on Exhibit A-1, attached hereto and by this reference made a part hereof and being more particularly described as follows:

Commencing at the S1/16 corner common to said Sections 7 and 12, located on the north line of Caspar Collins Addition No. 2, monumented by a brass cap:

Thence S88°41'59"W, along the south line of the NE¼SE¼ of said Section 12, also the north line of the Caspar Collins Addition No. 2, a distance of 350.00 feet to a point, being the Point of Beginning;

Thence continuing S88°41'59"W, along the south line of the parcel and the NE¼SE¼ of said Section 12, also the north line of Caspar Collins Addition No. 2, a distance of 267.93 feet to the southwest corner of the parcel;

Thence N01°18'01"W, a distance of 431.85 feet to a point;

Thence N63°25'13"E, a distance of 237.68 feet to a point;

Thence S86°49'22"E, a distance of 161.91 feet to a point;

Thence N65°41'20"E, a distance of 197.87 feet to a point;

Thence N85°02'49"E, a distance of 220.03 feet to a point;

Thence S59°00'25"E, a distance of 109.41 feet to a point;

Thence S80°27'03"E, a distance of 415.83 feet to a point;

Thence S72°21'24"E, a distance of 394.53 feet to a point;

Thence S00°01'59"W, a distance of 350.65 feet to the southeast corner of the parcel, located on the south line of Lot 3 (NW¼SW¼) of said Section 7, also the north line of the Caspar Collins Addition;

Thence S88°52'59"W, along the south line of the parcel and the south line of Lot 3 (NW¼SW¼) of said Section 7, and the north line of the Caspar Collins Addition, a distance of 490.94 feet to a point;

Thence N01°07'01"W, a distance of 152.74 feet to a point;

Thence S88°52'59"W, a distance of 233.49 feet to a point;

Thence N00°00'00"W, a distance of 96.78 feet to a point;

Thence N59°00'58"E, a distance of 49.25 feet to a point;

Thence N00°00'00"W, a distance of 122.12 feet to a point;

Thence N90°00'00"W, a distance of 103.78 feet to a point;

Thence N00°00'00"E, a distance of 32.86 feet to a point;

Thence S88°52'59"W, a distance of 595.44 feet to a point;

Thence S01°07'01"E, a distance of 432.12 feet to the Point of Beginning.

The above described parcel of land contains 11.94 acres, more or less and is subject to any rights-of-way and/or easements, reservations and encumbrances which have been legally acquired.

I hereby certify that this description was prepared from notes taken during an actual survey made under my direct supervision in September, 2021, and that on the basis of my information knowledge and belief as a Professional Land Surveyor that this description is true and correct.

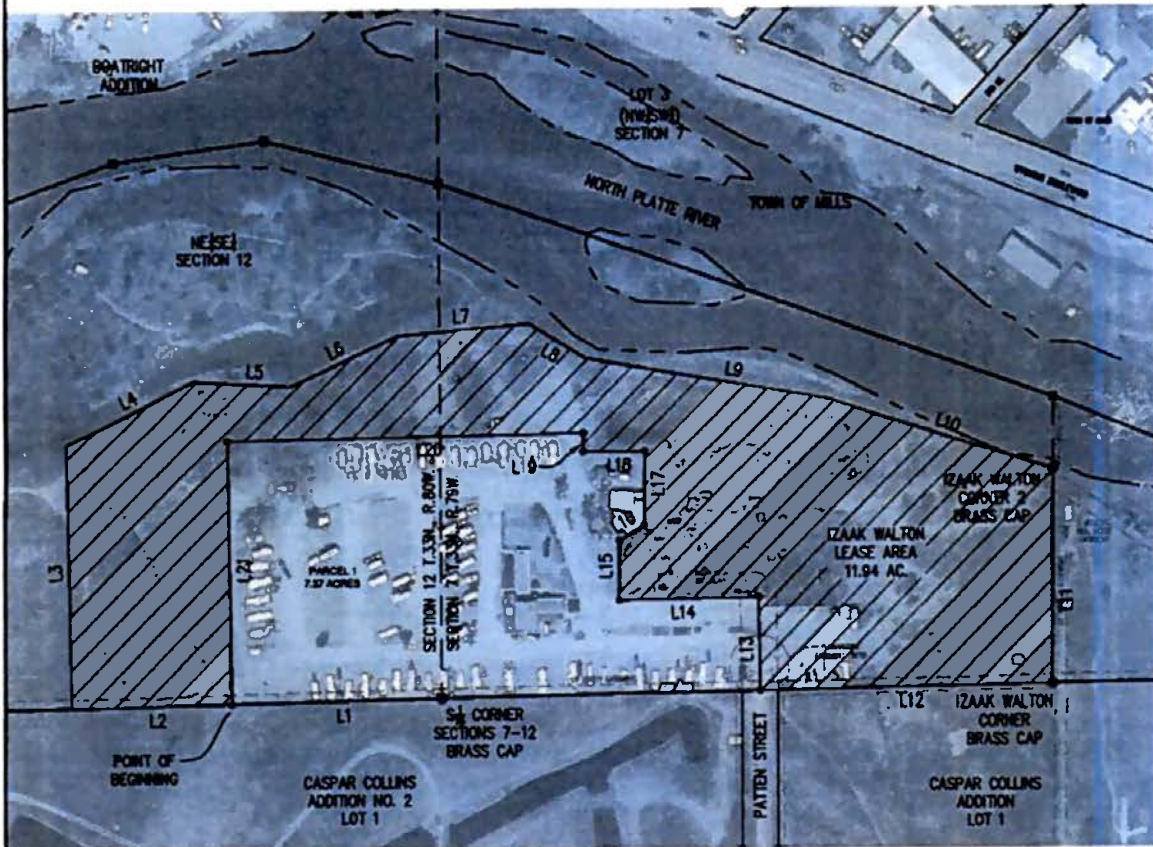

 WILLIAM R. FEHRING
 5528
 May 23, 2022

MODIFICATION IN ANY WAY OF THE FOREGOING DESCRIPTION IS STRICTLY PROHIBITED. I HAVE CAREFULLY REVIEWED THIS INFORMATION AND CERTIFY IT TO BE ACCURATE ON THE BASIS OF MY KNOWLEDGE AND BELIEF. ANY CHANGE, ADDITION OR DELETION OF ANY PART OF THIS DESCRIPTION WILL ACT TO VOID ANY WARRANTY OR RESPONSIBILITY, EXPRESSED OR IMPLIED, THAT I HAVE TOWARD THE SUBJECT PROPERTY.

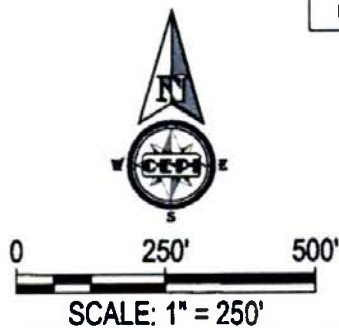

LINE TABLE		
Line #	Bearing	Length
L1	S88°41'59"W	350.00'
L2	S88°41'59"W	267.93'
L3	N178°01'W	431.85'
L4	N63°25'13"E	237.68'
L5	S86°49'22"E	161.91'
L6	N65°41'20"E	197.87'
L7	N85°02'49"E	220.03'
L8	S59°00'25"E	109.41'
L9	S80°27'03"E	415.83'
L10	S72°21'24"E	394.53'
L11	S0°01'59"W	350.65'

LINE TABLE		
Line #	Bearing	Length
L12	S88°52'59"W	490.94'
L13	N1°07'01"W	152.74'
L14	S88°52'59"W	233.49'
L15	N0°00'00"E	96.78'
L16	N59°00'58"E	49.25'
L17	N0°00'00"E	122.12'
L18	N90°00'00"W	103.78'
L19	N0°00'00"E	32.86'
L20	S88°52'59"W	595.44'
L21	S1°07'01"E	432.12'



Civil Engineering Professionals, Inc.
 6080 Enterprise Drive, Casper, WY 82609
 Phone 307.266.4346 Fax 307.266.0103
 www.cepi-casper.com

EXHIBIT "A-1"
IZAAK WALTON LEASE AREA
 Lot 3 (NW/4) Section 7, T.33N., R.79W.
 NE/4 Section 12, T.33N., R.79W.
 Natrona County, Wyoming
 May, 2022
 W.O. 21-221

M:\land 2021\Surveying\21-221 Izaak Walton League\Survey Plots\LEASE AREA.dwg, 5/23/2022, BJB

EXHIBIT A



EXHIBIT "A"
IZAAK WALTON LEAGUE
Portion of Lot 3 (NW¼SW¼)
Section 7, T.33N., R.79W., & NE¼SE¼
Section 12, T.33N., R.80W., 6th P.M.
Natrona, County, Wyoming
IZAAK WALTON PARCEL 1

A parcel of land situate within portions of Lot 3 (NW¼SW¼) of Section 7, T.33N., R.79W., 6th P.M., and the NE¼SE¼ of Section 12, T.33N., R.80W., 6th P.M., Natrona County, Wyoming, being more particularly described as follows:

Commencing at the S1/16 corner common to said Sections 7 and 12, located on the north line of Caspar Collins Addition No. 2, monumented by a brass cap and being the Point of Beginning::

Thence S88°41'59"W, along the south line of the NE¼SE¼ of said Section 12, also the north line of the Caspar Collins Addition No. 2, a distance of 350.00 feet to a point;

Thence N01°07'01"W, a distance of 432.12 feet to a point;

Thence N88°52'59"E, a distance of 595.44 feet to a point;

Thence S00°00'00"E, a distance of 32.86 feet to a point;

Thence N90°00'00"E, a distance of 103.78 feet to a point;

Thence S00°00'00"E, a distance of 122.12 feet to a point;

Thence S59°00'58"W, a distance of 49.25 feet to a point;

Thence S00°00'00"E, a distance of 96.78 feet to a point;

Thence N88°52'59"E, a distance of 233.49 feet to a point;

Thence S01°07'01"E, a distance of 152.74 feet to a point;

Thence S88°52'59"W, along the south line of the parcel and the south line of the NW¼SW¼ of said Section 7, and the north line of the Caspar Collins Addition, a distance of 535.08 feet to a point;

The above described parcel of land contains 7.37 acres, more or less and is subject to any rights-of-way and/or easements, reservations and encumbrances which have been legally acquired.

I hereby certify that this description was prepared from notes taken during an actual survey made under my direct supervision in September, 2021, and that on the basis of my information knowledge and belief as a Professional Land Surveyor that this description is true and correct.

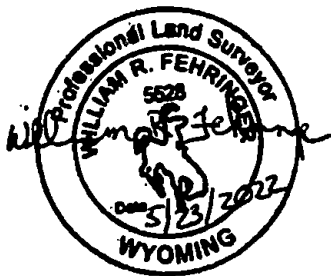

MODIFICATION IN ANY WAY OF THE FOREGOING DESCRIPTION IS STRICTLY PROHIBITED. I HAVE CAREFULLY REVIEWED THIS INFORMATION AND CERTIFY IT TO BE ACCURATE ON THE BASIS OF MY KNOWLEDGE AND BELIEF ANY CHANGE, ADDITION OR DELETION OF ANY PART OF THIS DESCRIPTION WILL ACT TO VOID ANY WARRANTY OR RESPONSIBILITY, EXPRESSED OR IMPLIED, THAT I HAVE TOWARD THE SUBJECT PROPERTY.

EXHIBIT B – PERSONAL PROPERTY

Exhibit B – Personal Property

Lodge – Whirlpool Refrigerator



Lodge – Whirlpool Stove



Lodge – Projector Screen

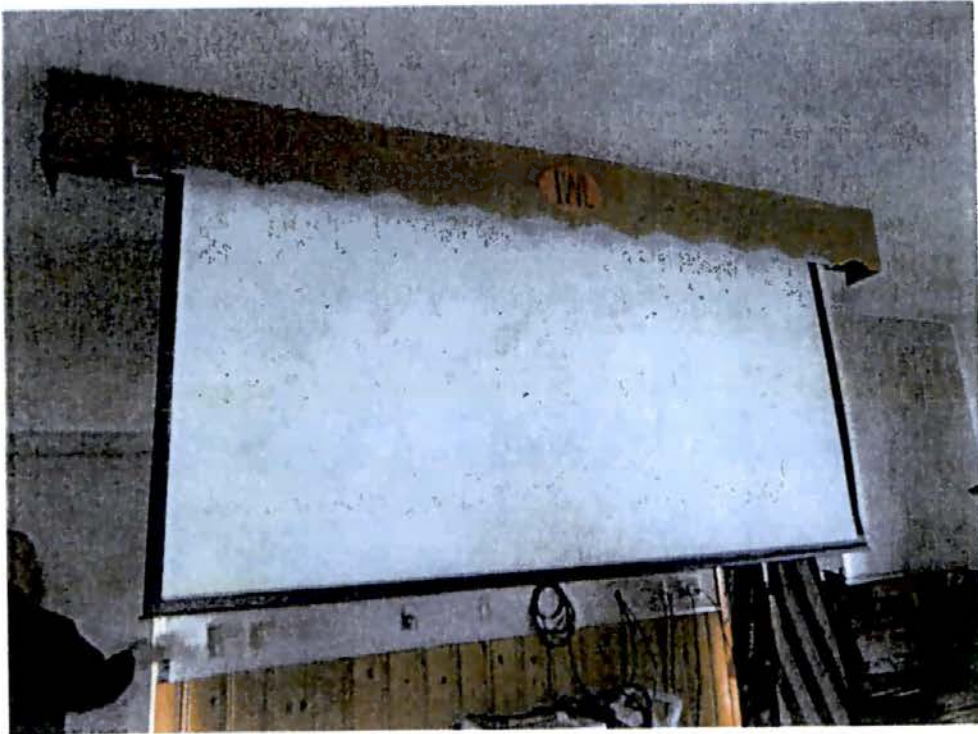

Lodge – Projector

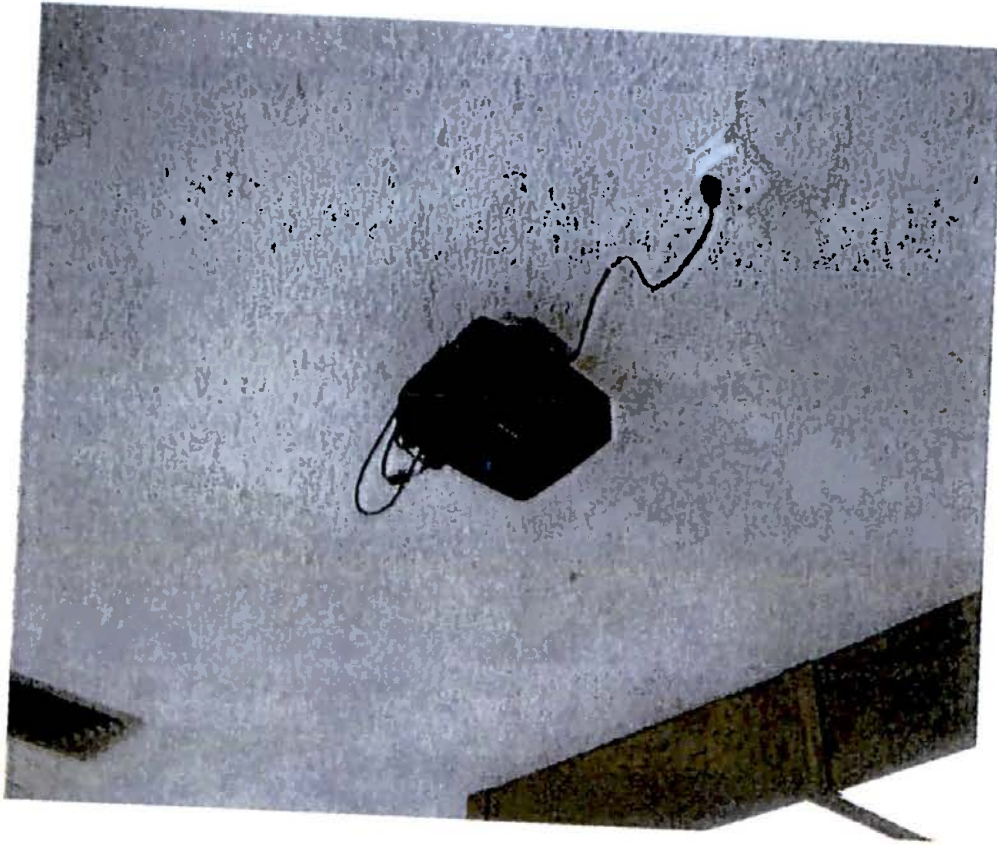

Lodge – Plastic Foldable Tables: 12 long, 1 medium, 2 short

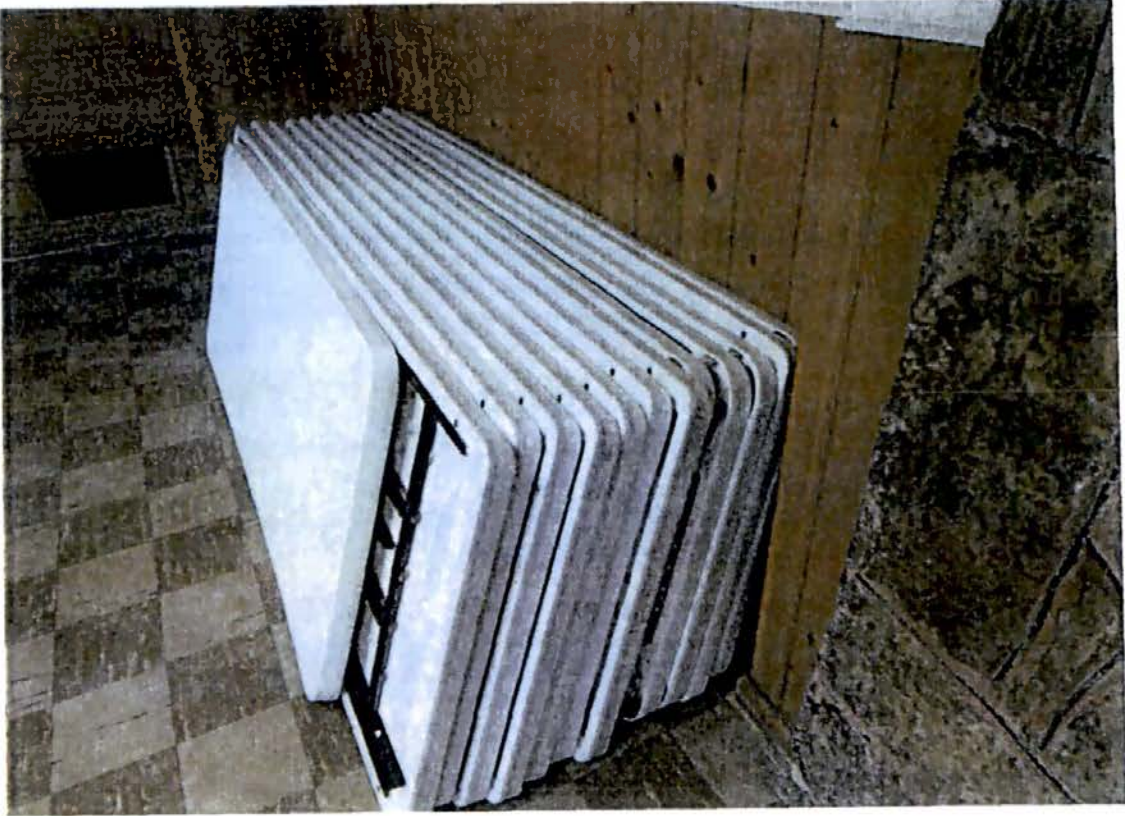

Lodge – 79 chairs



Lodge – Board Room – Whirlpool Stove



Lodge – Board Room – Refrigerator (brand unknown)

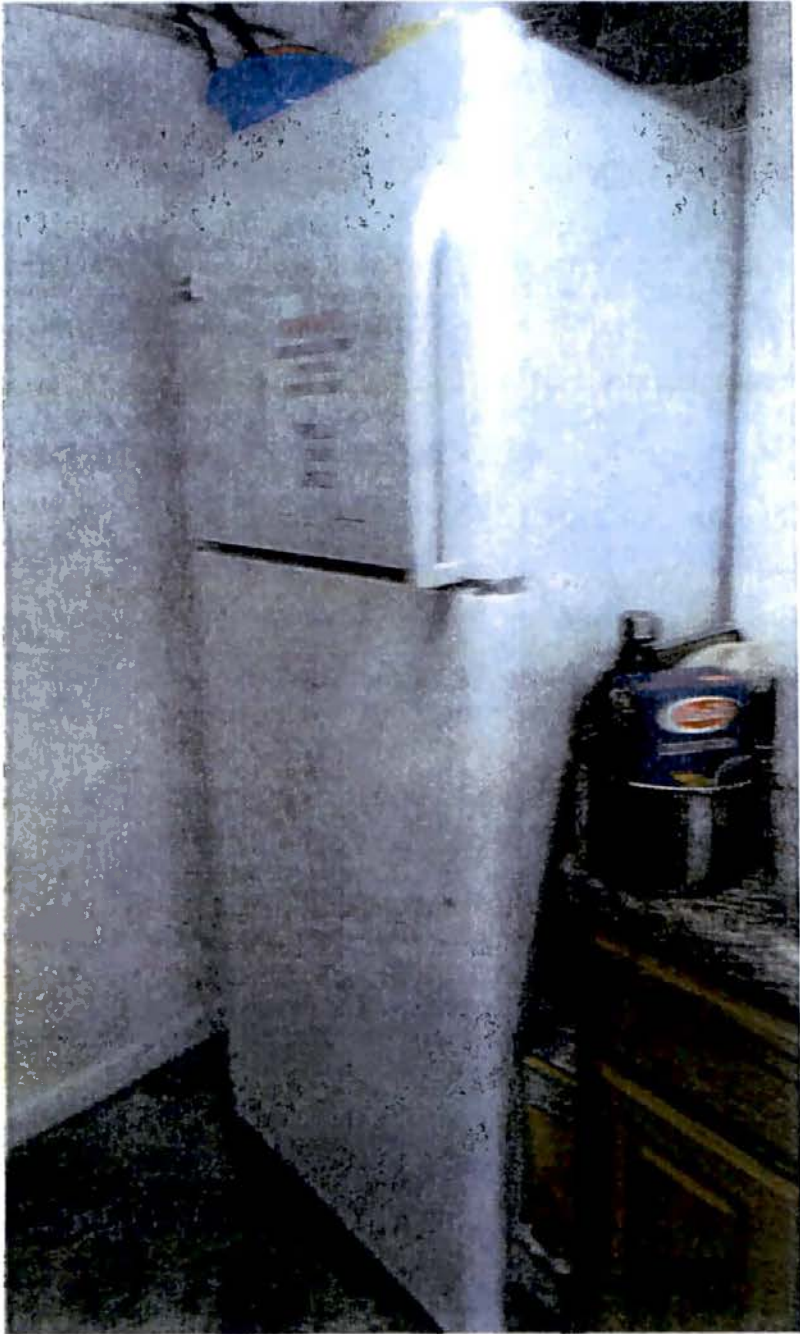

Lodge – Board Room – Ice Machine – Mazz Ice



Lodge – Board room table and 11 chairs



Shed behind the ledge (shed only)

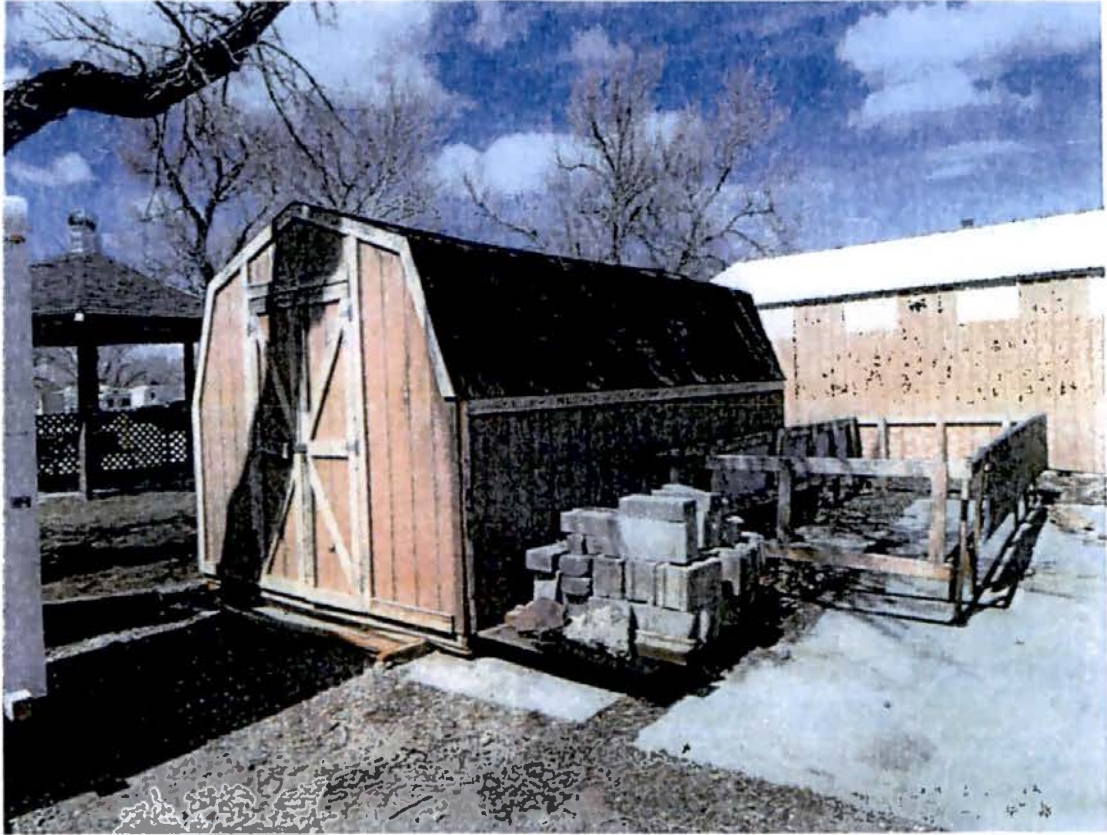

Picnic tables around the lodge (17 in total)



Picnic tables around the lodge (17 in total) - continued



Gazebo with picnic table

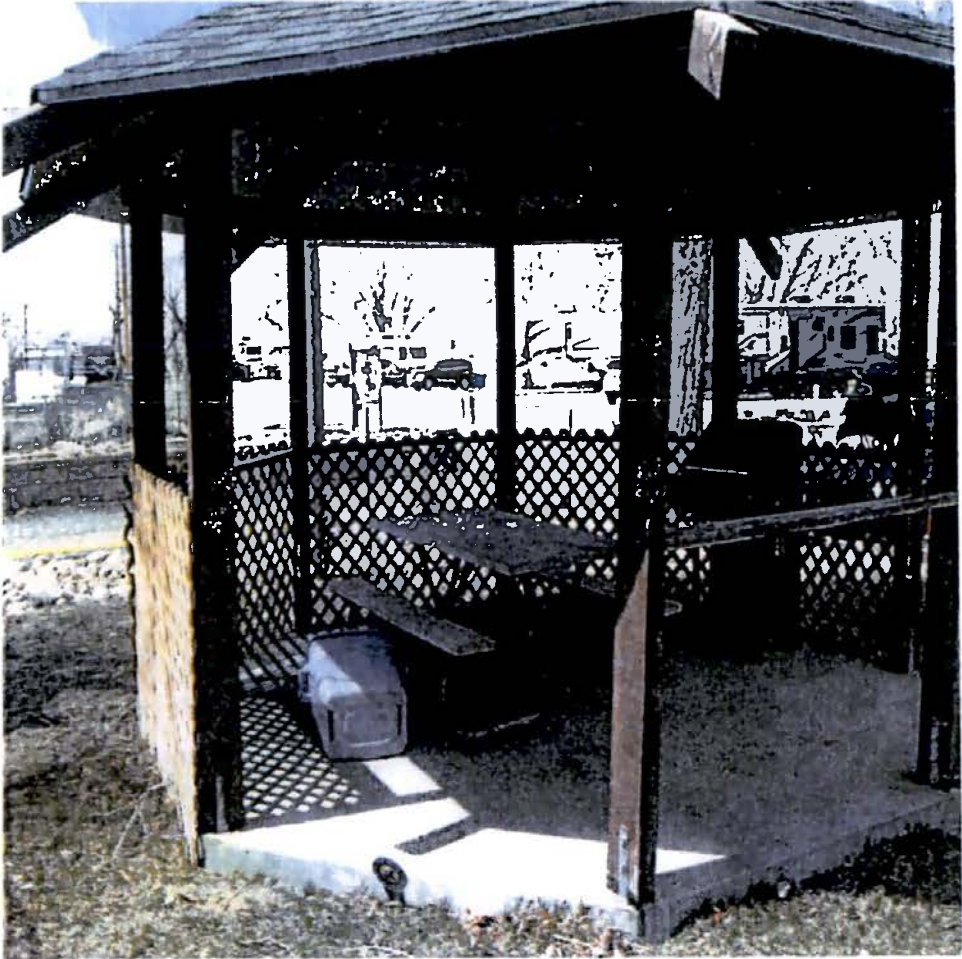

Maintenance garage – furnace (wood burning)



Gazebo and swings (outside bathrooms)



Playground equipment (outside bathrooms)



Bathroom bench (total 2 – women and men bathroom)



The office – wall installed AC unit



Office – deep freezer (total 2)



Office – Refrigerator



EXHIBIT C Agreed Upgrades/Repairs

Exhibit C

Property Inspection

The Property was inspected on December 17, 2020 with building inspectors from the City of Casper and Brian Connely, President of Charles E. Piersall Chapter, Izaak Walton League. The findings are outlined below.

As requested, an inspection walk through was completed for the Isaak Walton campground and adjoining buildings. Dan Elston (Building Official) and Shawn Barrett (Electrical Inspector) met with John Henley and Jolene Martinez of the City of Casper and accompanied them with other persons through the existing buildings and campground to identify the existing conditions of the property and structures.

It is important to realize that a change of ownership does not require building code upgrades to current code standards be completed for the sale. The following concerns should be addressed or recognized by both parties in terms of the change of ownership.

The Lodge: Built approx. 1938 and Meeting Hall Built 1954

- The roof has T-Lok type shingles that are in poor condition, typically insurance companies will not insure this type of roofing system. The roof shingles would need to be removed and replaced. This is for insurance purposes not a code requirement. *Per Jon Brady, roof was replaced after a windstorm and covered by insurance in 2020/2021.*
- Parking lot is not paved or striped with ADA parking identified. This is a City requirement for parking and with no work considered, it would be grandfathered at this time. If work was to commence in the future the Planning and Zoning Dept. would determine parking lot requirements.
- There is “negative” drainage around the building, this should be repaired to minimize any future damage to the structure.
- Unit heater and fire place insert are the only heat source in the east portion of the building. There is no conditioned air for this area. Required by code if future remodel was to be considered.
- Restrooms would need to be upgraded if remodel was considered.
- Unable to inspect attic furnace at time of walk through. Would not anticipate any changes.
- Exposed “Romex wiring” on the east end should be addressed.
- Exterior wall covering in disrepair on east end. (you can see through the wall)
- Electrical outlets not tamper resistant, not a code issue but a safety issue.

Shower Building:

- Reseal counters at the lavatories.
- Repair toilet that is 1” above the finished floor.

Boiler Room -Shower Building:

- No backflow preventer on 1 ½” incoming water service.

- No water meter, was explained that the water is free.
- Large electrical junction box requires a cover.

Maintenance Shop:

- Solid fuel burning appliances are not allowed in garages. Remove wood burning stove.

Campground Spaces:

- GFCI protection on electrical outlets recommended for safety, required by code if spaces were to be upgraded.
- Extension cords for heating water pipes should be repaired for safety purposes.
- All sewer connections from campers to sewer piping required to be "gas tight". Numerous are sealed with rags or nothing.

General Notes:

- There are many areas that GFCI electrical outlets should be installed for safety purpose even though it is not required by code until upgrades are considered.
- Extension cords are used for many purposes throughout and should be alleviated for safety. Fire Department annual inspection would require them to be removed.

RESOLUTION 22-91

A RESOLUTION APPROVING A LEASE AGREEMENT FOR THE CITY OF CASPER TO LEASE PORTIONS OF THE IZAAK WALTON LEAGUE PROPERTY TO THE CHARLES E. PIERSALL CHAPTER, IZAAK WALTON LEAGUE OF AMERICA, INCLUDING BUILDINGS AND COMMON AREAS LOCATED ON SAID PROPERTY.

WHEREAS, Charles E. Piersall Chapter, Izaak Walton League of America, is selling the Izaak Walton League property to the City of Casper; and,

WHEREAS, the Charles E. Piersall Chapter, Izaak Walton League of America, has operated from this location for many years, and has expressed an interest to continue its operations after the sale of the property to the City of Casper; and,

WHEREAS, the City of Casper desires to enter into a Lease Agreement with the Charles E. Piersall Chapter, Izaak Walton League of America; and,

WHEREAS, the negotiated Purchase and Sale Agreement for the purchase of Izaak Walton League property is explicitly contingent upon the Parties also agreeing to the terms of the Lease Agreement.

NOW, THEREFORE, BE IT RESOLVED BY THE GOVERNING BODY OF THE CITY OF CASPER, WYOMING: That the Mayor or the Mayor's designee is hereby authorized and directed to execute, and the City Clerk to attest, after the purchase by the City of the Izaak Walton property, a Lease Agreement between the City of Casper, Wyoming, and Charles E. Piersall Chapter, Izaak Walton League of America, for the use of a portion of the Izaak Walton League property, as reflected in the Lease Agreement, before Council.

PASSED, APPROVED, AND ADOPTED this 7th day of June, 2022.

APPROVED AS TO FORM:

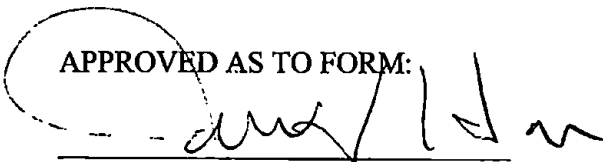

ATTEST:

Fleur Tremel
City Clerk



CITY OF CASPER, WYOMING
A Municipal Corporation

Ray Pacheco
Mayor

RESOLUTION NO. 22-189

A RESOLUTION RATIFYING AND APPROVING A LEASE AGREEMENT BETWEEN THE CITY OF CASPER, WYOMING, A WYOMING MUNICIPAL CORPORATION AND THE CHARLES E. PIERSALL, CHAPTER OF THE IZAAK WALTON LEAGUE OF AMERICA.

WHEREAS, the City of Casper purchased property from the Charles E. Piersall, Chapter of the Izaak Walton League of America contingent upon the City of Casper leasing a portion of the property to the Charles E. Piersall, Chapter of the Izaak Walton League of America under the terms and conditions set out in a Lease Agreement between the parties; and,

WHEREAS, Resolution 22-91 was adopted on the 7th day of June 2022, authorizing a Lease Agreement between the City of Casper, Wyoming and the Charles E. Piersall Chapter, Izaak Walton League of America; and,

WHEREAS, due to unforeseen circumstances, the closing and the sale of the property was delayed until August 26, 2022; and,

WHEREAS, the Lease Agreement was entered into on the 13th day of October 2022, and the lease commencement date was changed to the 13th day of October 2022, throughout the Agreement; and,

WHEREAS, the Governing Body desires to ratify and approve the Lease Agreement dated October 13, 2022, between the parties.

NOW, THEREFORE, BE IT RESOLVED BY THE GOVERNING BODY OF THE CITY OF CASPER, WYOMING: that the Governing Body ratifies the changes to the Lease Agreement between the City of Casper, Wyoming and the Charles E. Piersall, Chapter of the Izaak Walton League of America dated October 13, 2022, and the Mayor is authorized to sign the Lease Agreement.

PASSED, APPROVED, AND ADOPTED this 18th day of October 2022.

APPROVED AS TO FORM:

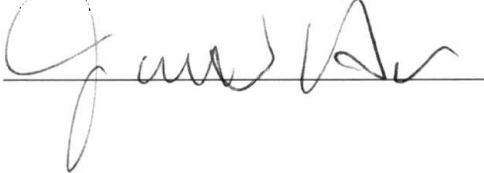

ATTEST:

Fleur Tremel
City Clerk

CITY OF CASPER, WYOMING
A Municipal Corporation

Ray Pacheco
Mayor

September 22, 2022

MEMO TO: J. Carter Napier, City Manager *JCN*
FROM: Tracey L. Belser, Support Services Director *TLB*
Dan Coryell, Fleet Manager
SUBJECT: Authorize the Purchase of Three (3) New Golf Course Greens Mowers in the Total Amount of \$167,982.00, Before Trade-In, for Use by the Casper Municipal Golf Course of the Parks, Recreation, and Public Facilities Department.

Meeting Type & Date
Regular Council Meeting
October 18, 2022

Action type
Minute Action

Recommendation
That Council, by minute action, authorize the purchase of three (3) new golf course greens mowers from Midland Implement Company, Billings, Montana, to be used by the Casper Municipal Golf Course of the Parks, Recreation, and Public Facilities Department, in the total amount of \$167,982.00 before trade-in.

Summary
On September 1, 2022 bids were publicly opened for three (3) new golf course greens mowers; two (2) bids were received. The new greens mowers are needed to maintain the quality of the greens putting surface, customer playability, and overall satisfaction of customers. This purchase will replace three (3) older golf course greens mowers that have all met the criteria needed for replacement, they are: Unit #82225 – a 2004 golf course greens mower with approximately 4,900 hours, Unit #82226 – a 2004 golf course greens mower with approximately 4,700 hours, and Unit #82250 - a 2014 golf course greens mower with approximately 2,400 hours.
Delivery of the three (3) new golf course greens mowers is expected in 180 days.

As required by Wyoming State Statute 15-1-113(b), the State of Wyoming notice was published in a local newspaper once a week for a minimum of two (2) consecutive weeks.

<u>Bid Item</u>	<u>Vendor</u>	<u>Amount</u>	<u>Trade-In</u>	<u>Total</u>
(3) Toro 3320 greens Mowers w/accessories	Midland Implement Billings, MO	\$167,982.00	\$3,500.00	\$164,482.00
(3) John Deere 2700 Greens mowers w/ Accessories	Stotz Equipment Casper, WY	\$182,500.00	\$4,000.00	\$178,500.00

The recommended purchase of the three (3) golf course greens mowers through Midland Implement meets all of the required specifications for equipment in this application.

Financial Considerations

This purchase was approved in the FY23 adopted budget for \$168,000.00 and is funded by One Cent funds.

Oversight/Project Responsibility

This purchase will be made by Dan Coryell, Fleet Manager. Oversight will be transferred to Randy Norvelle, Parks Division Manager, after the equipment is received.

Attachments

Bid Specifications

CITY OF CASPER
FLEET MAINTENANCE DIVISION
CITY OF CASPER
August 12, 2022

Notice is hereby given that the City of Casper, Wyoming will receive sealed bids at the Casper Service Center, 1800 E. K Street, Casper, Wyoming, **until 3:00 p.m., August 31, 2022** for the following:

Three (3) new **Golf Course Greens Mowers**, to be used by the Casper Municipal Golf Course of the Parks and Recreation Department.

General Specifications:

It is the intent of these specifications to specify the minimum requirement for the furnishing and delivery of (3) new Golf Course Greens Mowers, to be used by Casper Municipal Golf Course of the Parks and Recreation Department. Units shall be delivered complete and ready for service, as specified, and shall be equipped with all of the manufacturer's standard equipment, as advertised, whether or not specifically mentioned in these specifications, in addition to all other equipment and attachments specified herein.

MINIMUM SPECIFICATIONS

Golf Course Fairway Mower

- American Manufacturer _____
- Two sets of keys _____
- 2wd parallel hydrostatic _____
- 3 wheels _____
- Power Steering _____
- Tilt Steering Wheel _____
- Tires: 4 ply tires, smooth tread _____
- Current Model Year, 21 horsepower, gasoline _____
- On Board Power storage; belt driven generator/Motor _____
- Electric driven cutting units _____
- Two post ROPS with seatbelt _____
- 11-blade, 5-inch diameter Dual Point Adjustment
Cutting units. _____

Wihle front roller

Toolless hinged platform on traction unit

Toolless Reel Replacement

Collection baskets resting on Traction unit,
Not on front rollers

Additional set of cutting units for each machine

1 Set of verticut reels.

Miscellaneous

Operators and Service manual to be delivered to the
City of Casper along with the mower

2 Year Warranty minimum

All warranties to begin upon delivery of vehicle

Selling Dealer Must be able to pick up and warranty
repairs within 48 hrs. NO EXCEPTIONS

Copy of Order Confirmation to be provided upon
Completion of the order.

City of Casper shall be granted five (5) business days
Notice of delivery of the units in order to schedule
Vehicle intake appointment.

City of Casper shall be granted five (5) business days
From scheduled drop off to inspect/verify specification
compliance prior to full acceptance.

Vehicle shall be delivered with a full tank of fuel

Original titles to be delivered to 1800 E. "K"
Street, Casper, WY 82601, within 30 days
of Vehicle Delivery
Title to be made out as: City of Casper,
200 N. David, Casper, WY 82601

NOTE: This form may be duplicated.

Exceptions to any of the provisions of these specifications may be waived provided they are clearly stated in the Bid, and if in the opinion of the City of Casper, the Bid complied with the intent of the specification.

Should funding be inadequate to cover the items bid, all bids may be rejected or quantities adjusted to fit budget amount.

All contacts should be made through Dan Coryell, Casper Service Center, Casper, Wyoming, 82601. Phone 307-235-8410.

**PROPOSAL FOR FURNISHING
THREE (3) GOLF COURSE GREENS MOWERS
FOR THE PARKS AND RECREATION DEPARTMENT**

Proposal of (Name) _____
(Address) _____

to furnish equipment as specified to the City of Casper, Wyoming, in accordance with specifications dated August 12, 2022

BID ITEM: _____
Description: _____

Make and Model: _____
Federal Certified GVW: _____

- I. Price bid for Three (3) Golf Course Greens Mowers, as specified \$ _____
- II. Trade-in allowance for Unit #82225, 2004 Toro Green Master 3150
Serial #240000278, 4895 hours \$ _____
- III. Trade-in allowance for Unit #82226, 2004 Toro Green Master 3150
Serial #230001883, 4621 hours \$ _____
- IV Trade-in allowance for Unit #82250, 2014 John Deere 2500B
Serial #ITC250BDADT07032, 2359 hours \$ _____
- VII. NET COST TO THE CITY (Total Price): \$ _____
- VIII. Delivery: F.O.B. City of Casper within ____ calendar days after award of contract by City Council.
- IX. Trade in unit will be considered optional if, in the opinion of the City of Casper authorized staff, it is found to be in the best interest of the City of Casper to do so.

In addition to this proposal, the undersigned herewith submits complete information including specifications and descriptive literature to fully describe and illustrate the equipment and accessories offered. Incomplete bid specification will be considered non-compliant and rejected.

Bidder proposes to deliver equipment in accordance with the schedule above and agrees that liquidated damages will be charged to him in accordance with specifications if delivery is not made in accordance with said schedule.

A bid bond, certified check, or cashier's check made payable to the City of Casper, Wyoming, in an amount of five percent (5%) of the total amount of this bid is enclosed. The undersigned certifies that he understands the specifications relating to said bid security and agrees to the conditions set forth in said specifications.

Discounts will be allowed for prompt payment as follows:

10 Day _____%; 20 Days _____%; 30 Days _____%.

Submitted By: _____ Title: _____ Date: _____

Signature: _____ Phone: _____

**CITY OF CASPER, WYOMING
SPECIFICATIONS FOR
THREE (3) GOLF COURSE GREENS MOWERS
(Approved by the City Attorney, 2014)
Dated the 12TH day of August 2022**

I. GENERAL:

The following specifications, including exhibits, attached hereto, shall constitute the minimum acceptable specifications for the goods and/or services for which bids are requested. Bidders shall include all items standard to article bid, whether or not specifically mentioned in these specifications.

All goods shall be new and the latest current production models meeting the terms of the specifications.

No bids may be withdrawn within thirty (30) days after the scheduled closing time for receipt of bids without the consent of the City of Casper, Wyoming.

II. BID GUARANTY:

The City of Casper is required by Wyoming Statutes 15-1-113, to receive a certified check, cashier's check, bank draft upon a reputable bank, or a bid bond. If the bid is for more than one hundred and fifty thousand dollars (\$150,000) with sufficient surety in the amount of five percent (5%) of the total bid amount before it can accept and consider any bid. Bid with deposit shall be filed with the FLEET MAINTENANCE DIVISION, Casper Service Center, 1800 East "K" Street, Casper, WY 82601, securely sealed, and endorsed upon the outside of the wrapper, with a brief statement as to the nature for which the bid is provided. Upon bid award, such surety shall be returned to the unsuccessful bidder(s). In the case of the successful bidder, five percent (5%) surety will be retained by the City until a proper bond or other proper bid guarantee to secure performance has been filed and approved if required by the specifications of the bid.

III. SCHEDULE FOR DELIVERY AND LIQUIDATED DAMAGES:

Unless a schedule has been specified in the bidding documents, each bidder shall specify, in its proposal, the time required for delivery of his goods to the place designated.

The provisions of Section II BID GUARANTY, shall apply to all bids, contracts and delivery times as specified. Failure to enter into a contract for said bid with the city within 30 days of the award or failure to proceed and/or deliver upon said bid or contract will result in forfeiture of bid guarantee.

IV. PLACE OF DELIVERY:

The successful bidder shall deliver the goods to the City of Casper, Casper Service Center, 1800 East "K" Street, Casper, Wyoming, unless otherwise specified.

V. CONDITIONS OF DELIVERY; RIGHT OF INSPECTION:

Goods, when delivered, shall be accompanied by a Statement Dealer's Certificate of Servicing and Inspection signed by the bidder certifying that the goods have been inspected and complies in all respects to the contract. Bidder shall attach to said statement a certificate by the manufacturer of the goods certifying that said goods have been inspected and serviced in the event the goods are not manufactured by the bidder. The City may, in its discretion, waive this requirement.

The City further reserves the right to make an inspection of the goods within a reasonable time after delivery to ensure compliance with the contract. Failure by City to make such inspection or upon inspection, failure to discover defects which cannot reasonably be discovered upon inspection, shall not constitute a waiver or be a limitation upon any remedy which the City may have at law or in equity.

VI. WARRANTY:

Each bidder shall enclose, with their bid, a copy of the warranty which applies to the goods proposed to be furnished. The warranty supplied will be considered by the City in determining the responsibility of the bidders.

VII. SERVICE FACILITIES:

It is essential that repair parts and service be adequate and readily available so that the goods can be maintained in good operating condition without protracted time loss for repairs.

The BIDDER SHALL CLEARLY STATE in his proposal the extent to which he carries a complete inventory of repair parts and service facilities. The City reserves the right to evaluate past performance of each bidder in analyzing the bid received and to consider such evaluation, in addition to other factors, in awarding the contracts for equipment.

VIII. DETAILED SPECIFICATIONS:

Goods bid shall conform to the detailed specifications outlined for the various bid items, attached hereto. No deviations from the terms of the specifications will be allowed, and such deviations shall be grounds for rejection of any bid, provided, however, that the City may allow any deviation if it finds, in its sole discretion, that the deviation is not a material deviation.

If bidder submits a bid using differing materials from those specified, he shall submit complete specifications for those items, including proposed manufacturer and catalog numbers with appropriate literature. The City may consider such specifications if it finds, in its sole discretion, that said

specifications meet the intent of its specifications set forth herein and do not differ materially from its specifications.

IX. STATEMENT OF COMPLIANCE:

Should any requirement in these specifications not be included in manufacture's specifications sheets, bidder shall include with his bid, a statement of compliance. Failure to do so may be held as grounds for disqualification of bid.

X. CONSIDERATION OF BIDS:

The City of Casper, Wyoming, reserves the right to evaluate all bids received on the basis of the conformance with these specifications, the availability of repair parts, and the adequacy of service facilities, the delivery schedules, and other criteria as well as (net) cost, and to consider such evaluation in awarding contracts for the furnishing of the bid items specified. The City will award the contract to the lowest responsible bidder.

XI. PAYMENT:

The City shall make a lump sum payment upon delivery and acceptance of all goods bid. A complete City of Casper voucher shall be processed for payment after an invoice is received from the vendor. Payment will be made within forty-five (45) days pursuant to Wyoming State Statute 16-6-602.

Statute W.S. 16-6-602:

16-6-601. Definitions.

(a) As used in this article:

(i) "Agency" means any department, agency or other instrumentality of the state or of a political subdivision of the state;

W.S. 16-6-602. Payment of agency accounts; interest.

Except as provided by contract, any agency which purchases or procures goods and services from a nongovernmental entity shall pay the amount due within forty-five (45) days after receipt of a correct notice of amount due for the goods or services provided or shall pay interest from the forty-fifth day at the rate of one and one-half percent (1 1/2%) per month on the unpaid balance until the account is paid in full, unless a good faith dispute exists as to the agency's obligation to pay all or a portion of the account.

XII. SALES TAX EXEMPTION CERTIFICATE:

The City of Casper, Wyoming, is exempted for paying the sales tax specified by Wyoming Statutes, and from paying Federal Excise taxes. Upon request, a copy of an exemption certificate will be furnished to the successful bidder.

XIII. GOVERNING LAW:

In the event of any claim, suit, or demand which may result from a bid or bids submitted thereunder, or the award of any contract as a result of submission of a bid, the bidder or bidders agree that Wyoming law shall govern any such claim, suit, or demand the rights and duties of the parties thereunder.

XIV. ADDITIONAL INFORMATION:

If additional information is required, written instructions shall be issued. No oral instructions or interpretations will be considered binding unless confirmed in the form of addenda and shall be furnished to all bidders who shall submit a signed copy of all addenda with their bid. Please refer all questions to Dan Coryell, 1800 East "K" Street, Casper, Wyoming, 82601, (307) 235-8410.

September 22, 2022

MEMO TO: J. Carter Napier, City Manager *JCN*
FROM: Tracey L. Belser, Support Services Director *TLB*
Dan Coryell, Fleet Manager
SUBJECT: Authorize the Purchase of One (1) New One-Ton 4x4 Pickup With Snow Plow, Dump Bed, and Accessories in the Total Amount of \$88,189.00, Before Trade-In, for Use by the Weed and Pest Division of the Parks, Recreation, and Public Facilities Department.

Meeting Type & Date
Regular Council Meeting
October 18, 2022

Action type
Minute Action

Recommendation

That Council, by minute action, authorize the purchase of one (1) new one-ton 4x4 pickup with snow plow, dump bed, and accessories from Greiner Ford, Casper, Wyoming, to be used in the Weed and Pest Division of the Parks, Recreation, and Public Facilities Department, in the total amount of \$88,189.00 before trade-in.

Summary

On September 1, 2022 bids were publicly opened for one (1) new one-ton 4x4 pickup with snow plow, dump bed, and accessories; three (3) bids were received. This pickup truck will be used for all snow events and is the main salt truck for all public facilities maintained by the City of Casper. In addition, this truck will be used to pull mowers for rough area mowing. It is a common practice for the truck and trailer to be driven into the rough areas off pathways, the interstate ramps, and other city-owned and maintained lots.

This purchase will replace a similar older pickup truck, a 2005 Ford F250, Unit #83251. It has met all criteria needed for replacement, age 17 years and approximately 80,000 miles. Delivery of the new pickup is expected in 500 days.

As required by Wyoming State Statute 15-1-113(b), the State of Wyoming notice was published in a local newspaper once a week for a minimum of two (2) consecutive weeks.

<u>Bid Item</u>	<u>Vendor</u>	<u>Amount</u>	<u>Trade-In</u>	<u>Total</u>
(1) 2023 Ford F350 W/A TEC Up fitting of Snow Plow and Bed	Greiner Ford Casper, WY	\$98,619.50	\$2,186.00	\$96,433.50
(1) 2023 Ford F350 W/A TEC Up fitting of	Fremont Motors Sheridan, WY	\$95,390.00	\$3,050.00	\$92,340.00

<u>Snow Plow and Bed</u> <u>Bid Item</u>	<u>Vendor</u>	<u>Amount</u>	<u>Trade-In</u>	<u>Total</u>
(1) 2023 Ford F350 W/ABLE Up fitting of Snow Plow and Bed	Greiner Ford Casper, WY	\$88,189.00	\$2,186.00	\$86,003.00

The recommended purchase of the one-ton 4x4 pickup with snow plow, dump bed, and accessories through Greiner Ford meets all of the required specifications for equipment in this application.

Financial Considerations

This purchase was approved in the FY23 adopted budget for \$120,000.00 and is funded by Weed and Pest funds.

Oversight/Project Responsibility

This purchase will be made by Dan Coryell, Fleet Manager. Oversight will be transferred to Randy Norvelle, Parks Division Manager, after the equipment is received.

Attachments

Bid Specifications

CITY OF CASPER
FLEET MAINTENANCE DIVISION
CITY OF CASPER

August 9, 2022

Notice is hereby given that the City of Casper, Wyoming will receive sealed bids at the Casper Service Center, 1800 E. K Street, Casper, Wyoming, **until 3:00 p.m., August 30th, 2022** for the following:

One (1) New **One Ton 4x4 Pickup Truck with Snow Plow, Dump Body and Accessories**, to be used in the Weed and Pest Section of the Parks and Recreation Department.

General Specifications:

It is the intent of these specifications to specify the minimum requirement for the furnishing and delivery of One (1) new **One Ton 4x4 Pickup Truck with Snow Plow, Dump Body and Accessories**, to be used in the Weed and Pest Section of the Parks and Recreation Department. This unit shall be new with less than One Thousand Five hundred (1500) miles and be less than six months old. Unit shall be delivered complete and ready for service, as specified, and shall be equipped with all of the manufacturer's standard equipment, as advertised, whether or not specifically mentioned in these specifications, in addition to all other equipment and attachments specified herein.

MINIMUM SPECIFICATIONS

Cab and Chassis

- American Manufacturer _____
- Three sets of keys _____
- Mileage: 1500 miles or less (New) _____
- Minimum 7.3 L V8 Gasoline Engine _____
- Automatic Transmission _____
- Power Steering _____
- Tilt Steering Wheel _____
- Power Mirrors _____
- Power Windows _____
- Power Door Locks _____
- Cab – Regular cab or equivalent _____

Four Wheel Drive	_____
Electronic shift on the fly	_____
Dual Rear Wheel	_____
Tires/wheels – Radial ply tires as required for GVWR, 5 Tires and wheels (including spare), all season, all terrain tread	_____
Spare Tire & Wheel to include Jack & Lug Wrench	_____
AM/FM Radio with Bluetooth Factory Installed	_____
Heater/Defroster	_____
Four wheel anti-lock braking system	_____
Running boards	_____
Trailer/tow package	_____
Factory Installed Trailer Brake Controller	_____
7 Wire Trailer Plug	_____
Factory Air Conditioning	_____
Intermittent Wipers	_____
Engine Block Heater	_____
Permanent anti-freeze protection to minus 30 degrees F.	_____
Factory snow plow prep package	_____
Front Suspension meeting/exceeding plow requirements	_____
Factory installed back up camera and sensors	_____
Manufacturer's standard single color, white	_____
Upfitter Switches for Accessories	_____
Cloth seats, matching trim throughout in Standard color, Steel or equivalent Heavy Duty Vinyl Flooring throughout	_____
OEM heavy duty rubber floor mats	_____

Dump Body

Dump body must be a Knapheide model KDBDS916
Or an approved equal. Dump body will have drop sides
And be equipped with a tapered cab protector. A class V
Receiver hitch will also need to be installed. Hoist shall
Be a model KHA-1516SF or an approved equal - electric
Over hydraulic with a pendant control.

Two (2) underbody mount tool boxes sized to fit
Space allowed (one on either side of body).

Safety Accessories, Including Installation

Low profile beacon light, Federal Signal part number
454201 HL – 25, mounted on cab protector with a
Safety/security cage built around light to protect from
Debris. Wired to a spare upfitter switch.

Snow Plow Attachment, Including Installation

Western Wide-Out snow plow or approved equal

Retracted Width – 8’ Expanded Width – 10”

Back Drag Edge

Handheld controller W/Push Buttons

Rubber snow deflector

Shoe Kit

Installation included

2.5 CU. YD 8’ Salt/Sand Spreader with Installation

Polyethylene Hopper Construction

15 1/2” spinner (min.)

Dual electric motors

Installation included

Western Tornado or equal

Miscellaneous

5 Year 60,000 Mile Power Train Warranty

All warranties to begin upon delivery of fully assembled vehicle

Selling Dealer Must be able to pick up and warranty repairs within 48 hrs. NO EXCEPTIONS

Copy of Order Confirmation to be provided upon completion of order, full copy of specifications delivered with the completed unit

City of Casper shall be granted 10 business days from delivery to inspect/verify specification compliance prior to full acceptance

2 complete sets of parts manual and operator's manuals will be provided for the unit and all attachments included on the unit

All parts that are removed to install any aftermarket components will be given back to the Fleet Division unless compensation or prior arrangements are agreed upon for the removed parts

Vehicle shall be delivered with a full tank of fuel

Original titles to be delivered to 1800 E. "K" Street, Casper, WY 82601, within 30 days of Vehicle Delivery
Title to be made out as: City of Casper, 200 N. David, Casper, WY 82601

NOTE: This form may be duplicated.

Exceptions to any of the provisions of these specifications may be waived provided they are clearly stated in the Bid, and if in the opinion of the City of Casper, the Bid complied with the intent of the specification.

Should funding be inadequate to cover the items bid, all bids may be rejected or quantities adjusted to fit budget amount.

All contacts should be made through Dan Coryell, Casper Service Center, Casper, Wyoming, 82601.

Phone 307-235-8410.

**PROPOSAL FOR FURNISHING
ONE (1) NEW 1-TON 4x4 PICKUP TRUCK WITH SNOW PLOW, DUMP BODY AND
ACCESSORIES
FOR THE
WEED AND PEST SECION OF THE PARKS AND RECREATION DEPARTMENT**

Proposal of (Name) _____
(Address) _____

to furnish equipment as specified to the City of Casper, Wyoming, in accordance with specifications dated August 9, 2022.

BID ITEM: _____
Description: _____

Make and Model: _____
Federal Certified GVW: _____

- I. Price bid for One (1) new 1-ton 4x4 Pickup and body as specified \$ _____
- II. Price bid for Snow Plow Attachment, installed and as specified \$ _____
- III. Trade-in allowance for Unit 83251, 2005 Ford F250 2x4 Pickup
Truck VIN # 1FTNF20545EB15061 \$ _____
- V. NET COST TO THE CITY (Total Price): \$ _____
- VI. Delivery: F.O.B. City of Casper within ____ calendar days after award of contract by City Council.
- VII. Trade in unit will be considered optional if, in the opinion of the City of Casper authorized staff, it is found to be in the best interest of the City of Casper to do so.

In addition to this proposal, the undersigned herewith submits complete information including specifications and descriptive literature to fully describe and illustrate the equipment and accessories offered. Incomplete bid specification will be considered non-compliant and rejected.

Bidder proposes to deliver equipment in accordance with the schedule above and agrees that liquidated damages will be charged to him in accordance with specifications if delivery is not made in accordance with said schedule.

A bid bond, certified check, or cashier's check made payable to the City of Casper, Wyoming, in an amount of five percent (5%) of the total amount of this bid is enclosed. The undersigned certifies that he understands the specifications relating to said bid security and agrees to the conditions set forth in said specifications.

Discounts will be allowed for prompt payment as follows:

10 Day _____%; 20 Days _____%; 30 Days _____%.

Submitted By: _____ Title: _____ Date: _____

Signature: _____ Phone: _____

**CITY OF CASPER, WYOMING
SPECIFICATIONS FOR
ONE (1) NEW 1-TON 4x4 PICKUP TRUCK WITH
SNOW PLOW AND ACCESSORIES
(Approved by the City Attorney, 2014)
Dated the 9th Day of August 2022**

I. GENERAL:

The following specifications, including exhibits, attached hereto, shall constitute the minimum acceptable specifications for the goods and/or services for which bids are requested. Bidders shall include all items standard to article bid, whether or not specifically mentioned in these specifications.

All goods shall be new and the latest current production models meeting the terms of the specifications.

No bids may be withdrawn within thirty (30) days after the scheduled closing time for receipt of bids without the consent of the City of Casper, Wyoming.

II. BID GUARANTY:

The City of Casper is required by Wyoming Statutes 15-1-113, to receive a certified check, cashier's check, bank draft upon a reputable bank, or a bid bond. If the bid is for more than one hundred and fifty thousand dollars (\$150,000) with sufficient surety in the amount of five percent (5%) of the total bid amount before it can accept and consider any bid. Bid with deposit shall be filed with the FLEET MAINTENANCE DIVISION, Casper Service Center, 1800 East "K" Street, Casper, WY 82601, securely sealed, and endorsed upon the outside of the wrapper, with a brief statement as to the nature for which the bid is provided. Upon bid award, such surety shall be returned to the unsuccessful bidder(s). In the case of the successful bidder, five percent (5%) surety will be retained by the City until a proper bond or other proper bid guarantee to secure performance has been filed and approved if required by the specifications of the bid.

III. SCHEDULE FOR DELIVERY AND LIQUIDATED DAMAGES:

Unless a schedule has been specified in the bidding documents, each bidder shall specify, in its proposal, the time required for delivery of his goods to the place designated.

The provisions of Section II BID GUARANTY, shall apply to all bids, contracts and delivery times as specified. Failure to enter into a contract for said bid with the city within 30 days of the award or failure to proceed and/or deliver upon said bid or contract will result in forfeiture of bid guarantee.

IV. PLACE OF DELIVERY:

The successful bidder shall deliver the goods to the City of Casper, Casper Service Center, 1800 East "K" Street, Casper, Wyoming, unless otherwise specified.

V. CONDITIONS OF DELIVERY; RIGHT OF INSPECTION:

Goods, when delivered, shall be accompanied by a Statement Dealer's Certificate of Servicing and Inspection signed by the bidder certifying that the goods have been inspected and complies in all respects to the contract. Bidder shall attach to said statement a certificate by the manufacturer of the goods certifying that said goods have been inspected and serviced in the event the goods are not manufactured by the bidder. The City may, in its discretion, waive this requirement.

The City further reserves the right to make an inspection of the goods within a reasonable time after delivery to ensure compliance with the contract. Failure by City to make such inspection or upon inspection, failure to discover defects which cannot reasonably be discovered upon inspection, shall not constitute a waiver or be a limitation upon any remedy which the City may have at law or in equity.

VI. WARRANTY:

Each bidder shall enclose, with their bid, a copy of the warranty which applies to the goods proposed to be furnished. The warranty supplied will be considered by the City in determining the responsibility of the bidders.

VII. SERVICE FACILITIES:

It is essential that repair parts and service be adequate and readily available so that the goods can be maintained in good operating condition without protracted time loss for repairs.

The BIDDER SHALL CLEARLY STATE in his proposal the extent to which he carries a complete inventory of repair parts and service facilities. The City reserves the right to evaluate past performance of each bidder in analyzing the bid received and to consider such evaluation, in addition to other factors, in awarding the contracts for equipment.

VIII. DETAILED SPECIFICATIONS:

Goods bid shall conform to the detailed specifications outlined for the various bid items, attached hereto. No deviations from the terms of the specifications will be allowed, and such deviations shall be grounds for rejection of any bid, provided, however, that the City may allow any deviation if it finds, in its sole discretion, that the deviation is not a material deviation.

If bidder submits a bid using differing materials from those specified, he shall submit complete

specifications for those items, including proposed manufacturer and catalog numbers with appropriate literature. The City may consider such specifications if it finds, in its sole discretion, that said specifications meet the intent of its specifications set forth herein and do not differ materially from its specifications.

IX. STATEMENT OF COMPLIANCE:

Should any requirement in these specifications not be included in manufacture's specifications sheets, bidder shall include with his bid, a statement of compliance. Failure to do so may be held as grounds for disqualification of bid.

X. CONSIDERATION OF BIDS:

The City of Casper, Wyoming, reserves the right to evaluate all bids received on the basis of the conformance with these specifications, the availability of repair parts, and the adequacy of service facilities, the delivery schedules, and other criteria as well as (net) cost, and to consider such evaluation in awarding contracts for the furnishing of the bid items specified. The City will award the contract to the lowest responsible bidder.

XI. PAYMENT:

The City shall make a lump sum payment upon delivery and acceptance of all goods bid. A complete City of Casper voucher shall be processed for payment after an invoice is received from the vendor. Payment will be made within forty-five (45) days pursuant to Wyoming State Statute 16-6-602.

Statute W.S. 16-6-602:

16-6-601. Definitions.

(a) As used in this article:

(i) "Agency" means any department, agency or other instrumentality of the state or of a political subdivision of the state;

W.S. 16-6-602. Payment of agency accounts; interest.

Except as provided by contract, any agency which purchases or procures goods and services from a nongovernmental entity shall pay the amount due within forty-five (45) days after receipt of a correct notice of amount due for the goods or services provided or shall pay interest from the forty-fifth day at the rate of one and one-half percent (1 1/2%) per month on the unpaid balance until the account is paid in full, unless a good faith dispute exists as to the agency's obligation to pay all or a portion of the account.

XII. SALES TAX EXEMPTION CERTIFICATE:

The City of Casper, Wyoming, is exempted for paying the sales tax specified by Wyoming Statutes, and from paying Federal Excise taxes. Upon request, a copy of an exemption certificate will be furnished to the successful bidder.

XIII. GOVERNING LAW:

In the event of any claim, suit, or demand which may result from a bid or bids submitted thereunder, or the award of any contract as a result of submission of a bid, the bidder or bidders agree that Wyoming law shall govern any such claim, suit, or demand the rights and duties of the parties thereunder.

XIV. ADDITIONAL INFORMATION:

If additional information is required, written instructions shall be issued. No oral instructions or interpretations will be considered binding unless confirmed in the form of addenda and shall be furnished to all bidders who shall submit a signed copy of all addenda with their bid. Please refer all questions to Dan Coryell, 1800 East "K" Street, Casper, Wyoming, 82601, (307) 235-8410.

September 22, 2022

MEMO TO: J. Carter Napier, City Manager *JCN*
FROM: Tracey L. Belser, Support Services Director *TLB*
Dan Coryell, Fleet Manager
SUBJECT: Authorize the Purchase of One (1) New 3000 Ton Per Hour Loader Mounted Snow Blower in the Total Amount of \$239,850.00, Before Trade-In, for Use by the Streets and Traffic Division of the Public Services Department.

Meeting Type & Date
Regular Council Meeting
October 18, 2022

Action type
Minute Action

Recommendation

That Council, by minute action, authorize the purchase of one (1) new 3000 ton per hour loader mounted snow blower from Kois Brothers Equipment Company, Commerce City, Colorado, to be used in the Streets and Traffic Division of the Public Services Department, in the total amount of \$239,850.00 before trade-in.

Summary

On September 1, 2022 bids were publicly opened for one (1) new 3000 ton per hour loader mounted snow blower; two (2) bids were received. The loader mounted snow blower is used heavily in winter months for removing windrows made from plowing snow to the middle of the street. Plowing to the middle is generally done to clear a pathway throughout the city to accommodate emergency vehicles and the motoring public during snowstorms as well as minimizing the impact to residential driveways, commercial driveways and storm drains.

The City of Casper Streets and Traffic Division currently has two (2) loader mounted snow blowers in their fleet. Having two blowers allows the continuance of operations during snow events, should there be a breakdown or if one unit needs serviced. Also, having two blowers operating simultaneously during very large snow events helps keep city businesses open and traffic flowing. This purchase will replace one (1) of the loader mounted snow blowers, a 2008 RPM TECH, unit #70973. It has met all of the criteria needed for replacement, age 14 years and approximately 2500 hours.

Staff is recommending to purchase the LaRue loader mounted snow blower over the lower priced Kodiak loader mounted snow blower. The Kodiak snow blower had many exceptions in their formal bid and could not build a product that City of Casper specifications required. One major exception by the Kodiak snow blower was the front ribbon or auger. City of Casper specifications called for a "Heavy duty serrated single ribbon, one-piece type, at 42" maximum diameter designed to force snow into impeller fan." The Kodiak snow blower is manufactured with a two-piece ribbon, one left side and one right side. Staff had the opportunity test and operate snow blowers with both styles of ribbons and feel the single one-piece ribbon is far less maintenance and handles the windrows much better than the two-piece ribbon. Other examples include delivery time, operator familiarity, and part accessibility. Delivery for the Kodiak snow blower is expected to be 180 days while the LaRue snow blower is expected in 40 days.

As required by Wyoming State Statute 15-1-113(b), the State of Wyoming notice was published in a local newspaper once a week for a minimum of two (2) consecutive weeks.

<u>Bid Item</u>	<u>Vendor</u>	<u>Amount</u>	<u>Trade-In</u>	<u>Total</u>
(1) Kodiak Loader Mounted Snow Blower	Torgersons Equipment Gillette, WY	182,631.57	No Offer	\$182,631.57

<u>Bid Item</u>	<u>Vendor</u>	<u>Amount</u>	<u>Trade-In</u>	<u>Total</u>
(1) LaRue Loader Mounted Snow Blower	Kois Brothers Equipment Commerce City, CO	239,850.00	\$10,000.00	\$229,850.00

The recommended purchase of the loader mounted snow blower through Kois Brothers Equipment meets all of the required specifications for equipment in this application.

Financial Considerations

This purchase was approved in the FY23 adopted budget for \$250,000.00 and is funded by One Cent funds.

Oversight/Project Responsibility

This purchase will be made by Dan Coryell, Fleet Manager. Oversight will be transferred to Shad Rodgers, Streets and Traffic Division Manager, after the equipment is received.

Attachments

Bid Specifications

CITY OF CASPER
FLEET MAINTENANCE DIVISION
CITY OF CASPER
(307)235-8410
August 12, 2022

Notice is hereby given that the City of Casper, Wyoming will receive sealed bids at the Fleet Office, Casper Service Center, 1800 E. "K" Street, Casper, Wyoming, **until 3:00 p.m., September 1, 2022** for the following:

ONE (1) NEW 3000 TONS PER HOUR LOADER MOUNTED SNOW BLOWER. This unit is to be used by the Streets Division of the Public Services Department; unit must have the minimum specifications of:

General

Specifications: It is the intent of these specifications to specify the minimum requirement for the furnishing and delivery of **ONE (1) NEW 3000 TONS PER HOUR LOADER MOUNTED SNOW BLOWER.** The unit shall be new and have less than fifty (50) hours and be less than twelve (12) months old, with full factory warranty. Unit shall be delivered complete and ready for service, as specified, and shall be equipped with all of the manufacturer's standard equipment, as advertised, whether or not specifically mentioned in these specifications, in addition to all other equipment and attachments specified herein.

<u>ITEM</u>	<u>MINIMUM SPECIFICATIONS</u>	<u>BIDDERS SPECIFICATIONS</u>
1.	UNIT	
	Unit will be a standard and current production model	_____
	Rotary self-contained loader mounted two stage blower system and engine as one single unit.	_____ _____
	Blower hitch and controls for mounting on a Caterpillar 938M with the Caterpillar Fusion Coupler.	_____ _____
	Blower shall come complete with a mounting assembly with wedge locking hooks mounted to blower and shall be compatible with the Caterpillar Fusion Coupler on a 938M.	_____ _____ _____ _____
2.	CAPACITY	
	3,000 tons/hour minimum. Casting distance up to 150 ft through the impeller/volute and up to 40 ft through truck loading chute.	_____ _____ _____

- | | | | |
|----|------------------|---|---|
| 3. | DIMENSIONS | Cutting Width: min 110"
Overall Height: max 139" (loading chute at minimum height)
Cutting Height: min 48"
Maximum Weight up to 11,900 lbs | <hr/> <hr/> <hr/> <hr/> |
| 4. | RIBBON | Heavy Duty serrated Single Ribbon, one piece type, at 42" maximum diameter designed to force snow into impeller fan.

Shall be bolt on and replaceable. | <hr/> <hr/> <hr/> |
| 5. | IMPELLER | 40" minimum diameter.
No less than five bolt-on impeller blades.
HEAVY DUTY impeller casing 40 in. minimum (1016 mm) nominal diameter and constructed of 3/8in.(9.6mm) steel with chromium carbide wear surfacing treatment. Impeller casing rotation is hydraulically operated through a worm gear and rotates through 140°. | <hr/> <hr/> <hr/> <hr/> <hr/> <hr/> <hr/> |
| 6. | IMPELLER HOUSING | Shall be capable of right or left hand casting without the use of the truck loading chute | <hr/> <hr/> |
| 7. | LOADING CHUTE | Two stage hydraulic telescoping chute (minimum of 18" extension) to cast snow left or right.

Chute shall load dump body trucks that are approximately 10 ft above ground. Chute will have a minimum of a 300 degree rotation.

HEAVY DUTY LONG LIFE Flexible and directional sections made of 3/8 in. (9.6mm) steel with chromium carbide wear surfacing treatment. Flexible and directional sections made of steel having a minimum thickness of 5 mm (3/16 in.) and hardness minimum of 500 Brinell. Flexible section tilts through two (2) hydraulic cylinders to control the projection distance from 3 to 15 m (10 to 50 ft.).

Chute will be hydraulic or hydrostatic gear operated (No chain welded to the chute base will be accepted in the chute rotating mechanism) | <hr/> <hr/> <hr/> <hr/> <hr/> <hr/> <hr/> <hr/> <hr/> <hr/> <hr/> |
| 8. | BLOWER FRAME/ | Blower Frame/Auger-Ribbon Housing shall be Fully welded construction with 100,000psi steel minimum, | <hr/> <hr/> |

RIBBON HOUSING

capable of withstanding the force of blowing snow and from pushing trucks with a Vendor/Factory installed truck push block.

A City of Casper designed push block will be installed by the vendor to withstand forces of pushing trucks without damage to the blower. Push block will be modeled after existing City of Casper blower units push block (Unit# 70744).

9. ENGINE

Shall be powered by a minimum of 360 hp fully electronic turbo charged diesel engine. 2022 emission compliant. Shall be compatible with wireless controls.

Shall have a heavy duty air filter to provide centrifugal moisture separation and drain. Air filter will be protected and waterproof with an air cleaner service indicator.

90 AMP charging system.

1000 Watt blockheater, with 120v external waterproof receptacle.

Anti-freeze protection to minus 40 degrees F.

Engine will be situated within the unit so as to not block the operator's forward view.

Residential type muffler system (Cowl Muffler) to reduce engine noise in residential areas.

Warning System-High water temperature; low water; low oil pressure buzzer in addition to gauges, and lights, with automatic shut down. Mounted on In-Cab control center.

Tachometer in control center

Sheet metal engine housing with access panels that tilt over with helper spring galvanized steel engine cowling to facilitate accessibility of the engine and its components.

10. FUEL TANK

Fuel tank of a sufficient capacity to ensure an 8 hour of operation in normal use.

102 mm (4 in.) diameter ventilated fuel cap with safety valve in the event of pressurization.

11. HYDRAULIC SYSTEM Will be of sufficient size and capacity to operate all the necessary hydraulic functions and shall be controlled from the cab by the operator.
- Heavy-duty electro-hydraulic valves with insulated electric connections.
- Oil tank equipped with a screened breather cap and a sight glass or dip stick gauge.
- A bolt on inspection door on top of the tank should be provided.
- All hydraulic hoses are attached and suitably protected to avoid wear due to vibrations.
- Hydraulic pump shall be direct driven from engine or transmission. Steel tank with site gauge and a replaceable filter.
12. POWER TRAIN SYSTEM Clutch drive shall be maintenance free clutch 3 discs. The clutch should be engageable/disengageable hydraulically and controlled from the cab.
- Chain and gear system or hydrostatic pump and motor system. All sprockets and chains are lubricated in appropriate oil bath.
- Two (2) shear bolt flanges to protect the transmission drive, one for the complete system and another for the auger.
- All input and output shafts of the gear box and drop box are splined type which drive the impeller. Shafts with **key way shaft or gears** are not acceptable for the gear box and drop box for the impeller drive.
13. SKATES Minimum of three (3) skates/shoes. One (1) placed in the center and one placed on each side. Height adjustable. Carbide, bolt-on, replaceable. Total wear surface of skates must be 1935 cm² (300 in.²) minimum with carbide insert 580 cm² (90 in.²) minimum.
14. SCRAPER BLADES Shall be bolt on and full width of chromium carbide construction.

15. SAFETY SHEAR PINS All snow engaging augers, ribbons, fans, and impellers will have a shear pin/shear bolt protection system.
- Shear system will be easily accessible without the removal of covers.
- Shear pins/bolts will be easily removed with normal hand tools.
16. CONTROLS Quickly detachable in-cab mounted control center shall be right side mounted and compatible with a Caterpillar 938M
- Control box and instrument panel installed in the wheel loader's cab. Maximum volume of all boxes should be 960 cm³ (378.5 in.³).
- Control Center shall be equipped with all necessary switches and controls to allow full operation of all blower functions. A dial indicating the data from engine controller (ECM) of the communication SAE J1939 must be installed on the control box indicating voltage, oil pressure and temperature. Fault or error Data codes must also available via this gauge. Illuminated fuel level gauge. Ignition key switch. Illuminated tachometer and hour meter. Switch for clutch engagement and disengagement. Rocker switch for variable engine throttle control. Red emergency Kill button (mushrooms type) installed near the joystick multi-functional control.
- Control Center shall be illuminated and all switches, gauges and controls shall be labeled.
- Control cable and connectors will be plug-in, quickly detachable and of sufficient length to keep cable away from pinch points and allow full loader lifting and turning operations.
- Control cable connecting plugs shall be metal (NO PLASTIC CONNECTORS) and shall have strain relief protection.
- Multi-function joystick installed in the wheel loader's cab for hydraulic control functions.
1. Chute tip up (back on control)
 2. Down (forward on control)

- 3. right, left & remote throttle
- 4. Joystick will be mounted ergonomically correct position on the operator's right and not interfere with loader controls.

Shall also provide Wireless Remote controls of Blower all functions shall be controlled including start/stop of engine, speed, directional blower, elevations of loading, directional chute (includes a remote kill switch).

17. ELECTRICAL 12 Volt Negative Ground

All electrical wires, connectors and cables shall be weather/water proof.

18. ACCESSORIES Night work lights with flasher/marker lights. Two mounted on front and two mounted on chute.
 Two sets of extra skates/shoes.
 100 extra shear pins/shear bolts.
 Hour meter
 Auto lube system for grease able fittings.

19. RUST PROOFING All surfaces and welds will be cleaned, primed and painted. One (1) coat of epoxy primer (60 microns minimum) and three (3) coats of polyurethane paint (60 microns minimum) (yellow)

20. MANUALS Two (2) complete sets of operator's manuals, two (2) sets of service manuals, and two (2) sets of parts manuals shall be supplied or an acceptable electronic version of the above mentioned manuals.

21. WARRANTY Specify in writing, to include all parts and labor F.O.B. Casper, for a minimum 12 month period.

List options for extended warranty with pricing.

The manufacturer must ensure a 24 h service in the snow season and keep an inventory all the essential parts for the normal operation for the snow blower.

22. DELIVERY **Unit shall be delivered with a full tank of fuel, properly blended for the weather conditions if required.**

**Unleaded gasoline to be minimum of 85% octane
diesel fuel to be at least the minimum requirements
of blended #2/#1 diesel fuel with proper additives to
correspond with climate conditions.**

**A copy of the order confirmation to be provided
upon completion of order.**

**Original title shall be provided within 30 days of
unit delivery to 1800 E. K St., Casper, WY 82601.
Title to be made out as: City of Casper, 200 N.
David, Casper, WY 82601.**

18. OPTIONS

Service software, adapters and/or cables, and any
hardware required for diagnostics of the unit shall be
provided upon delivery.

Operator training is, given at the place of use, for at
least 8 hours and will have to be provided at the latest
2 weeks after delivery. The training will
include/understanding the general maintenance of the
snowblower for the mechanics and proper operation
methods for the operators.

NOTE: These forms may be duplicated.

Exceptions to any of the provisions of these specifications may be waived provided they are clearly stated in the bid, and if in the opinion of the City of Casper, the bid complied with the intent of the specification.

Should funding be inadequate to cover the items bid, all bids may be rejected or quantities adjusted to fit budget amount.

All contacts should be made through Dan Coryell, Casper Service Center, Casper, Wyoming, 82601. Phone 307-235-8410.

**PROPOSAL FOR FURNISHING
ONE (1) NEW 3000 TONS PER HOUR LOADER MOUNTED SNOW BLOWER FOR THE
PUBLIC SERVICES DEPARTMENT STREETS DIVISION**

Proposal of (Name) _____
(Address) _____

to furnish equipment as specified to the City of Casper, Wyoming, in accordance with specifications dated August 12, 2022.

BID ITEM: _____
Description: _____

Make and Model: _____
Federal Certified GVW: _____

- I. Price bid for one (1) new 3000 tons per hour loader mounted snow blower, as specified \$ _____
- II. Trade-in allowance for Unit #70973, 2008 RPM, #2378RPM 1064 hours. \$ _____
- III. NET COST TO THE CITY:
(Total Price) \$ _____
- IV. Delivery: F.O.B. manufacturer of the City of Casper's choice within ____ calendar days after award of contract by City Council.
- V. Trade in unit will be considered optional if, in the opinion of the City of Casper authorized staff, it is found to be in the best interest of the City of Casper to do so.

In addition to this proposal, the undersigned herewith submits complete information, including specifications and descriptive literature to fully describe and illustrate the equipment and accessories offered. Incomplete bid specification will be considered non-compliant and rejected.

Bidder proposes to deliver equipment in accordance with the schedule above and agrees that liquidated damages will be charged to him in accordance with specifications if delivery is not made in accordance with said schedule.

A bid bond, certified check, or cashier's check made payable to the City of Casper, Wyoming, in an amount of five percent (5%) of the total amount of this bid is enclosed as per requirements of section II. The undersigned certifies that he understands the specifications relating to said bid security and agrees to the conditions set forth in said specifications.

Discounts will be allowed for prompt payment as follows:

10 Day _____%; 20 Days _____%; 30 Days _____%.

Submitted By: _____ Title: _____ Date: _____

Signature: _____ Phone: _____

CITY OF CASPER, WYOMING
SPECIFICATIONS FOR
ONE (1) NEW 3000 TONS PER HOUR LOADER MOUNTED SNOW BLOWER
(Approved by the City Attorney, 2014)
Dated the 12th Day of August, 2022

I. GENERAL:

The following specifications, including exhibits, attached hereto, shall constitute the minimum acceptable specifications for the goods and/or services for which bids are requested. Bidders shall include all items standard to article bid, whether or not specifically mentioned in these specifications.

All goods shall be new and the latest current production models meeting the terms of the specifications.

No bids may be withdrawn within thirty (30) days after the scheduled closing time for receipt of bids without the consent of the City of Casper, Wyoming.

II. BID GUARANTY:

The City of Casper is required by Wyoming Statutes, 15-1-113, to receive a certified check, cashier's check, bank draft upon a reputable bank, or a bid bond in the amount of five percent (5%) of the total bid shall be provided for each bid submitted. If the bid is for more than one hundred and fifty thousand dollars (\$150,000), only a bid bond with sufficient surety in the amount of five percent (5%) of the total bid amount will be accepted to consider any bid. Bid with deposit shall be filed with the FLEET OFFICE, Casper Service Center, 1800 E. "K" Street, Casper, WY 82601, securely sealed, and endorsed upon the outside of the wrapper, with a brief statement as to the nature for which the bid is provided. Upon bid award, such surety shall be returned to the unsuccessful bidder(s). In the case of the successful bidder, five percent (5%) surety will be retained by the City until a proper bond or other proper bid guarantee to secure performance has been filed and approved if required by the specifications of the bid.

III. SCHEDULE FOR DELIVERY AND LIQUIDATED DAMAGES:

Unless a schedule has been specified in the bidding documents, each bidder shall specify, in its proposal, the time required for delivery of his goods to the place designated.

The provisions of Section II BID GUARANTY, shall apply to all bids, contracts and delivery times as specified. Failure to enter into a contract for said bid with the city within 30 days of the award or failure to proceed and/or deliver upon said bid or contract will result in forfeiture of bid guarantee.

IV. PLACE OF DELIVERY:

The successful bidder shall deliver the goods to the City of Casper, Casper Service Center, 1800 East "K" Street, Casper, Wyoming, unless otherwise specified.

V. CONDITIONS OF DELIVERY; RIGHT OF INSPECTION:

Goods, when delivered, shall be accompanied by a Statement Dealer's Certificate of Servicing and Inspection signed by the bidder certifying that the goods have been inspected and complies in all respects to the contract. Bidder shall attach to said statement a certificate by the manufacturer of the goods certifying that said goods have been inspected and serviced in the event the goods are not manufactured by the bidder. The City may, in its discretion, waive this requirement.

The City further reserves the right to make an inspection of the goods within a reasonable time after delivery to ensure compliance with the contract. Failure by City to make such inspection or upon inspection, failure to discover defects which cannot reasonably be discovered upon inspection, shall not constitute a waiver or be a limitation upon any remedy which the City may have at law or in equity.

VI. WARRANTY:

Each bidder shall enclose, with their bid, a copy of the warranty which applies to the goods proposed to be furnished. The warranty supplied will be considered by the City in determining the responsibility of the bidders.

VII. SERVICE FACILITIES:

It is essential that repair parts and service be adequate and readily available so that the goods can be maintained in good operating condition without protracted time loss for repairs.

The BIDDER SHALL CLEARLY STATE in his proposal the extent to which he carries a complete inventory of repair parts and service facilities. The City reserves the right to evaluate past performance of each bidder in analyzing the bid received and to consider such evaluation, in addition to other factors, in awarding the contracts for equipment.

VIII. DETAILED SPECIFICATIONS:

Goods bid shall conform to the detailed specifications outlined for the various bid items, attached hereto. No deviations from the terms of the specifications will be allowed, and such deviations shall be grounds for rejection of any bid, provided, however, that the City may allow any deviation if it finds, in its sole discretion, that the deviation is not a material deviation.

If bidder submits a bid using differing materials from those specified, he shall submit complete specifications for those items, including proposed manufacturer and catalog numbers with appropriate literature. The City may consider such specifications if it finds, in its sole discretion, that said specifications meet the intent of its specifications set forth herein and do not differ materially from its specifications.

IX. STATEMENT OF COMPLIANCE:

Should any requirement in these specifications not be included in manufacture's specifications sheets, bidder shall include with his bid, a statement of compliance. Failure to do so may be held as grounds for disqualification of bid.

X. CONSIDERATION OF BIDS:

The City of Casper, Wyoming, reserves the right to evaluate all bids received on the basis of the conformance with these specifications, the availability of repair parts, and the adequacy of service facilities, the delivery schedules, and other criteria as well as (net) cost, and to consider such evaluation in awarding contracts for the furnishing of the bid items specified. The City will award the contract to the lowest responsible bidder.

XI. PAYMENT

The City shall make a lump sum payment upon delivery and acceptance of all goods bid. A complete City of Casper voucher shall be processed for payment after an invoice is received from the vendor. Payment will be made within forty-five (45) days pursuant to Wyoming State Statute 16-6-601.

Statute W.S. 16-6-602:

16-6-601. Definitions.

(a) As used in this article:

(i) "Agency" means any department, agency or other instrumentality of the state or of a political subdivision of the state;

W.S. 16-6-602. Payment of agency accounts; interest.

Except as provided by contract, any agency which purchases or procures goods and services from a nongovernmental entity shall pay the amount due within forty-five (45) days after receipt of a correct notice of amount due for the goods or services provided or shall pay interest from the forty-fifth day at the rate of one and one-half percent (1 1/2%) per month on the unpaid balance until the account is paid in full, unless a good faith dispute exists as to the agency's obligation to pay all or a portion of the account.

XII. SALES TAX EXEMPTION CERTIFICATE:

The City of Casper, Wyoming, is exempted for paying the sales tax specified by Wyoming Statutes, and from paying Federal Excise taxes. Upon request, an exemption certificate will be furnished to the successful bidder.

XIII. GOVERNING LAW:

In the event of any claim, suit, or demand which may result from a bid or bids submitted thereunder, or the award of any contract as a result of submission of a bid, the bidder or bidders agree that Wyoming law shall govern any such claim, suit, or demand the rights and duties of the parties thereunder.

XIV. ADDITIONAL INFORMATION:

If additional information is required, written instructions shall be issued. No oral instructions or interpretations will be considered binding unless confirmed in the form of addenda and shall be furnished to all bidders who shall submit a signed copy of all addenda with their bid. Please refer all questions to Dan Coryell, 1800 East "K" Street, Casper, Wyoming, 82601, (307) 235-8410.